

122 Gauge mounting dimensions

Dimensions are in inches

PROPRIETARY AND CONFIDENTIAL
 THE INFORMATION CONTAINED IN THIS DRAWING IS THE SOLE PROPERTY OF LASERLINC, INC. ANY REPRODUCTION IN PART OR AS A WHOLE WITHOUT THE WRITTEN PERMISSION OF LASERLINC, INC IS PROHIBITED.

		UNLESS OTHERWISE SPECIFIED:		NAME	DATE	LaserLinc, Inc.	
		DIMENSIONS ARE IN INCHES		DRAWN	JEL	06/02/06	TITLE: 122 Mounting Dimensions
		TOLERANCES:		CHECKED			
		FRACTIONAL ±		ENG APPR.			
		ANGULAR: MACH ± BEND ±		MFG APPR.			
		TWO PLACE DECIMAL ±0.010		Q.A.			SIZE DWG. NO. REV B 0
		THREE PLACE DECIMAL ±0.005		COMMENTS: 63 RA surface finish			
		INTERPRET GEOMETRIC TOLERANCING PER:					SCALE: 1:1 WEIGHT: SHEET 1 OF 2
		MATERIAL					
NEXT ASSY	USED ON	FINISH					
APPLICATION		DO NOT SCALE DRAWING					

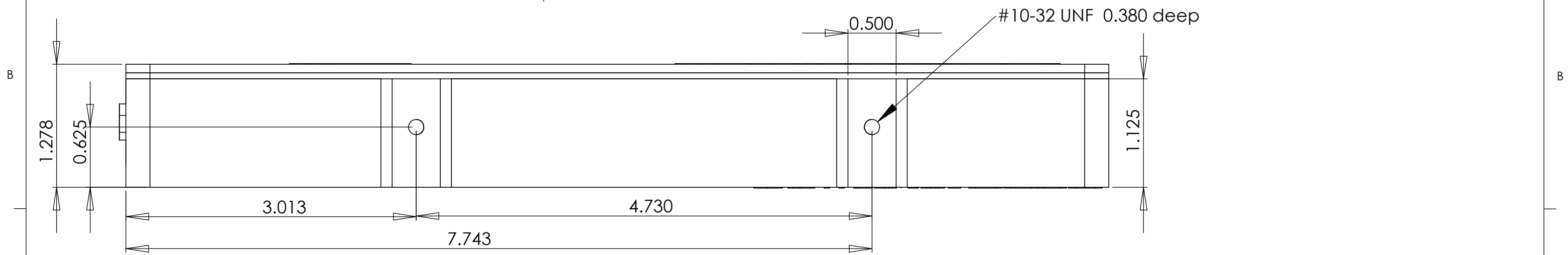
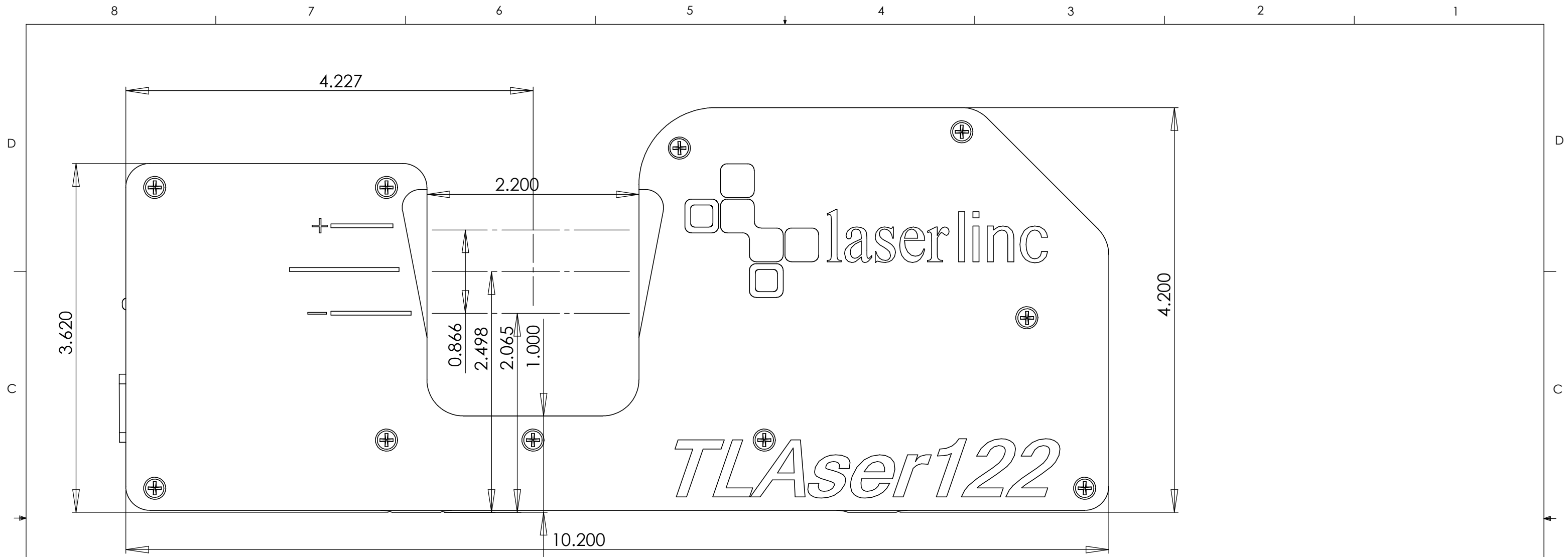

PROPRIETARY AND CONFIDENTIAL
 THE INFORMATION CONTAINED IN THIS DRAWING IS THE SOLE PROPERTY OF LASERLINC, INC. ANY REPRODUCTION IN PART OR AS A WHOLE WITHOUT THE WRITTEN PERMISSION OF LASERLINC, INC IS PROHIBITED.

		UNLESS OTHERWISE SPECIFIED:		NAME	DATE	LaserLinc, Inc.	
		DIMENSIONS ARE IN INCHES		DRAWN	JEL	06/02/06	TITLE: 122 Mounting Dimensions
		TOLERANCES:		CHECKED			
		FRACTIONAL ±		ENG APPR.			
		ANGULAR: MACH ± BEND ±		MFG APPR.			
		TWO PLACE DECIMAL ±0.010		Q.A.			SIZE B
		THREE PLACE DECIMAL ±0.005		COMMENTS: 63 RA surface finish		DWG. NO.	
		INTERPRET GEOMETRIC TOLERANCING PER:				SCALE: 1:1	WEIGHT:
		MATERIAL				SHEET 2 OF 2	
		FINISH					
NEXT ASSY	USED ON	DO NOT SCALE DRAWING					
APPLICATION							