

8 7 6 5 4 3 2 1

D
C
B
A

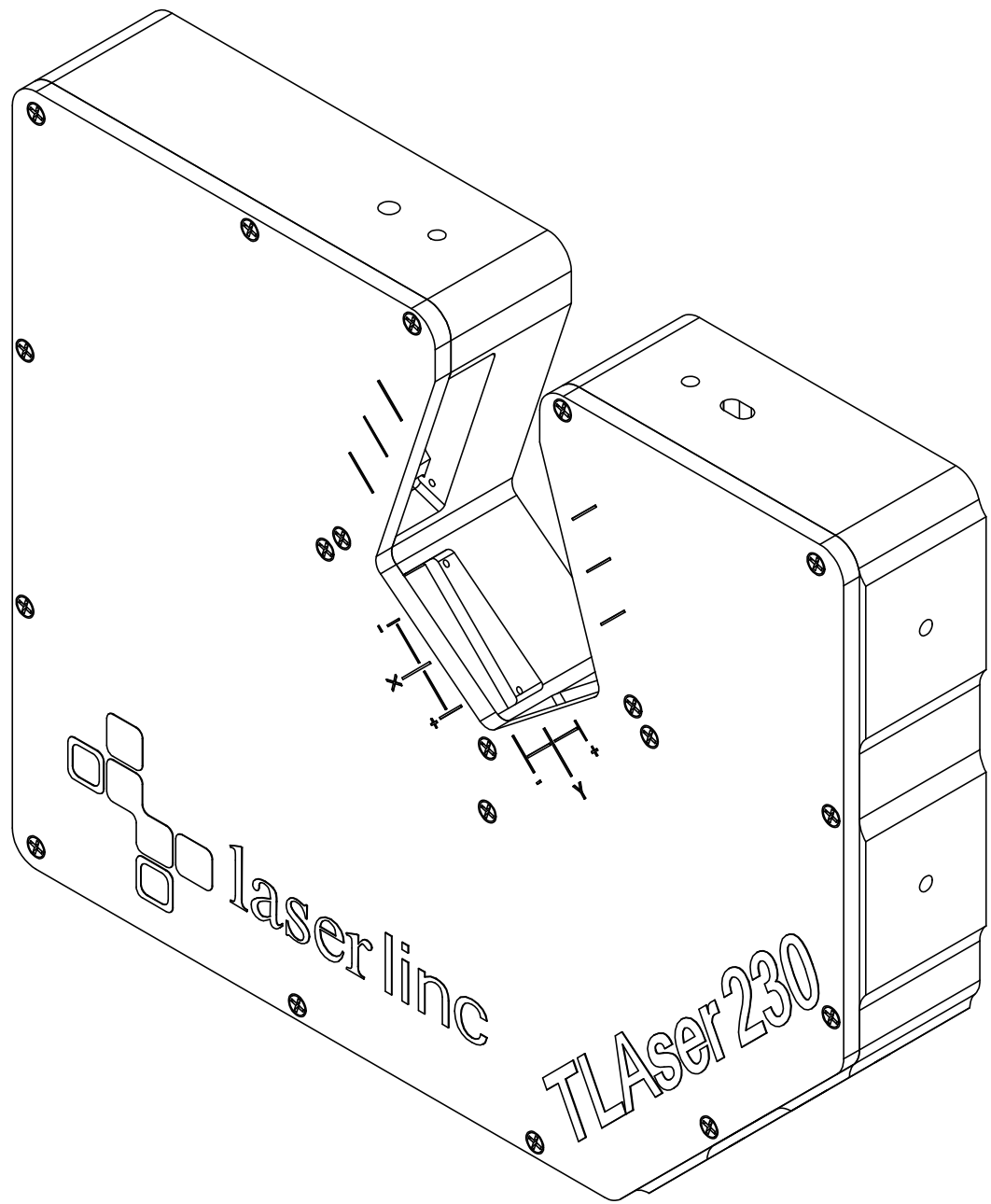

Mounting Dimensions For 230 Gauge

Dimensions are in inches

PROPRIETARY AND CONFIDENTIAL
 THE INFORMATION CONTAINED IN THIS DRAWING IS THE SOLE PROPERTY OF LASERLINC, INC. ANY REPRODUCTION IN PART OR AS A WHOLE WITHOUT THE WRITTEN PERMISSION OF LASERLINC, INC IS PROHIBITED.

		UNLESS OTHERWISE SPECIFIED:		NAME	DATE	LaserLinc, Inc.	
		DIMENSIONS ARE IN INCHES		DRAWN	JEL	06/01/06	TITLE: 230 Mounting dimensions
		TOLERANCES:		CHECKED			
		FRACTIONAL ±		ENG APPR.			
		ANGULAR: MACH ± BEND ±		MFG APPR.			
		TWO PLACE DECIMAL ±0.010		Q.A.			SIZE B
		THREE PLACE DECIMAL ±0.005		COMMENTS: 63 RA surface finish		DWG. NO.	
		INTERPRET GEOMETRIC TOLERANCING PER:				SCALE: 1:2	
		MATERIAL				WEIGHT:	
NEXT ASSY		USED ON				SHEET 1 OF 4	
APPLICATION		DO NOT SCALE DRAWING					

8 7 6 5 4 3 2 1

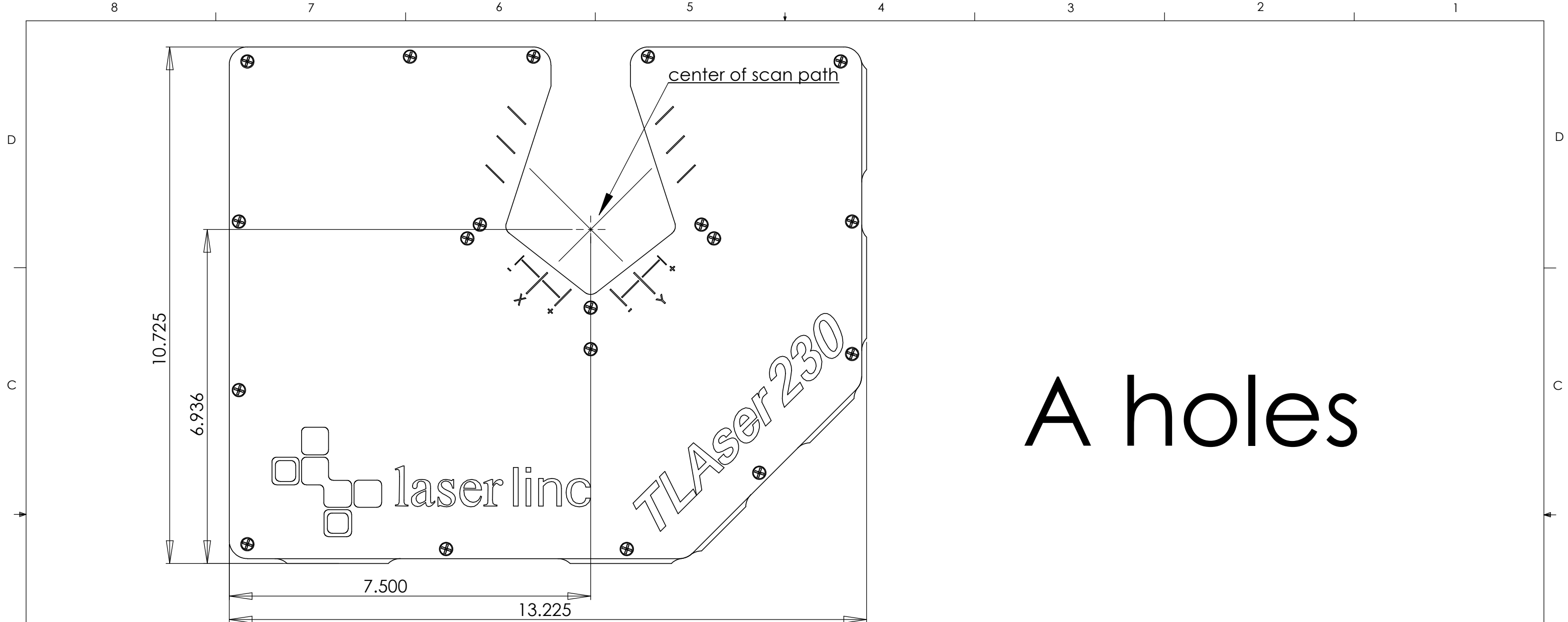

A holes

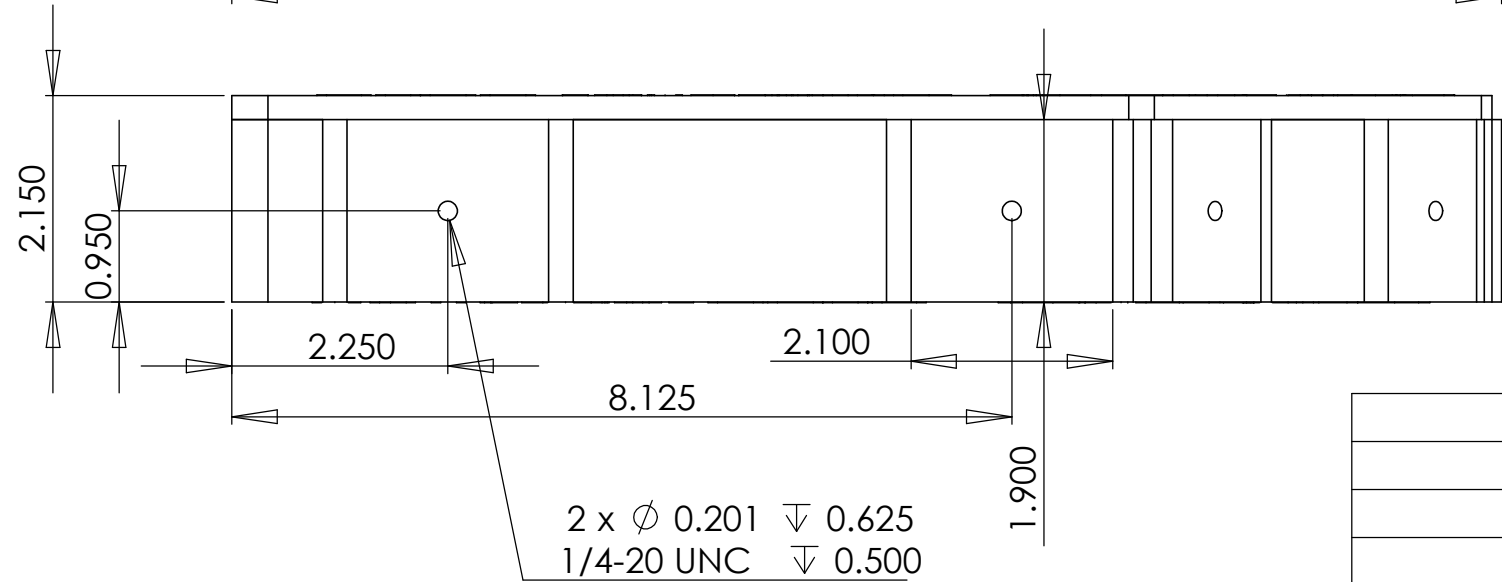

2 x Ø 0.201 0.625
1/4-20 UNC 0.500

PROPRIETARY AND CONFIDENTIAL
THE INFORMATION CONTAINED IN THIS DRAWING IS THE SOLE PROPERTY OF LASERLINC, INC. ANY REPRODUCTION IN PART OR AS A WHOLE WITHOUT THE WRITTEN PERMISSION OF LASERLINC, INC IS PROHIBITED.

		UNLESS OTHERWISE SPECIFIED:				LaserLinc, Inc.	
		DIMENSIONS ARE IN INCHES		DRAWN	JEL	DATE	06/01/06
		TOLERANCES:		CHECKED		TITLE:	
		FRACTIONAL ±		ENG APPR.		230 Mounting dimensions	
		ANGULAR: MACH ± BEND ±		MFG APPR.			
		TWO PLACE DECIMAL ±0.010		Q.A.			
		THREE PLACE DECIMAL ±0.005		COMMENTS:			
		INTERPRET GEOMETRIC TOLERANCING PER:		63 RA surface finish		SIZE	DWG. NO.
		MATERIAL				B	
		FINISH					REV
NEXT ASSY	USED ON						0
APPLICATION		DO NOT SCALE DRAWING				SCALE: 1:2	WEIGHT:
						SHEET 2 OF 4	

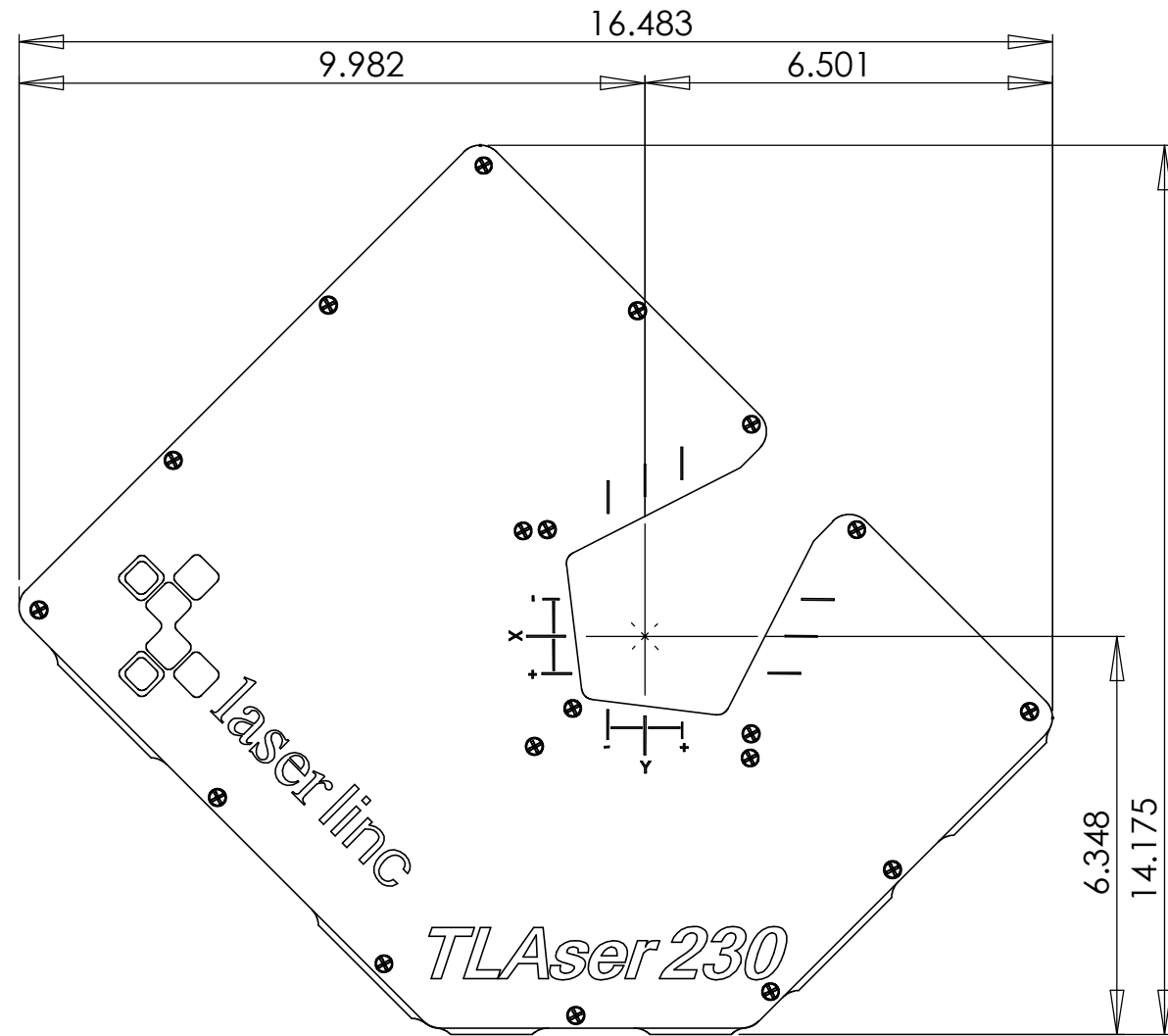

B holes

2 x ϕ 0.201 ∇ 0.625
 1/4-20 UNC ∇ 0.375

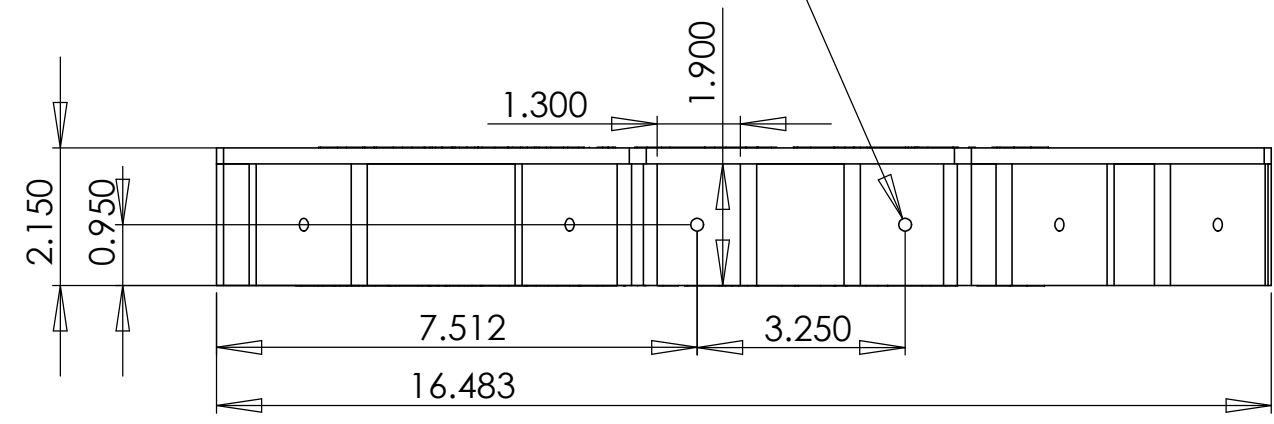

PROPRIETARY AND CONFIDENTIAL
 THE INFORMATION CONTAINED IN THIS DRAWING IS THE SOLE PROPERTY OF LASERLINC, INC. ANY REPRODUCTION IN PART OR AS A WHOLE WITHOUT THE WRITTEN PERMISSION OF LASERLINC, INC IS PROHIBITED.

		UNLESS OTHERWISE SPECIFIED:		NAME	DATE	LaserLinc, Inc.	
		DIMENSIONS ARE IN INCHES		DRAWN	JEL	06/01/06	TITLE: 230 Mounting dimensions
		TOLERANCES:		CHECKED			
		FRACTIONAL \pm		ENG APPR.			
		ANGULAR: MACH \pm BEND \pm		MFG APPR.			
		TWO PLACE DECIMAL \pm 0.010		Q.A.			SIZE B
		THREE PLACE DECIMAL \pm 0.005		COMMENTS:	63 RA surface finish		
		INTERPRET GEOMETRIC TOLERANCING PER:				DWG. NO.	REV 0
		MATERIAL				SCALE: 1:3	WEIGHT:
		FINISH				SHEET 3 OF 4	
NEXT ASSY	USED ON	DO NOT SCALE DRAWING					

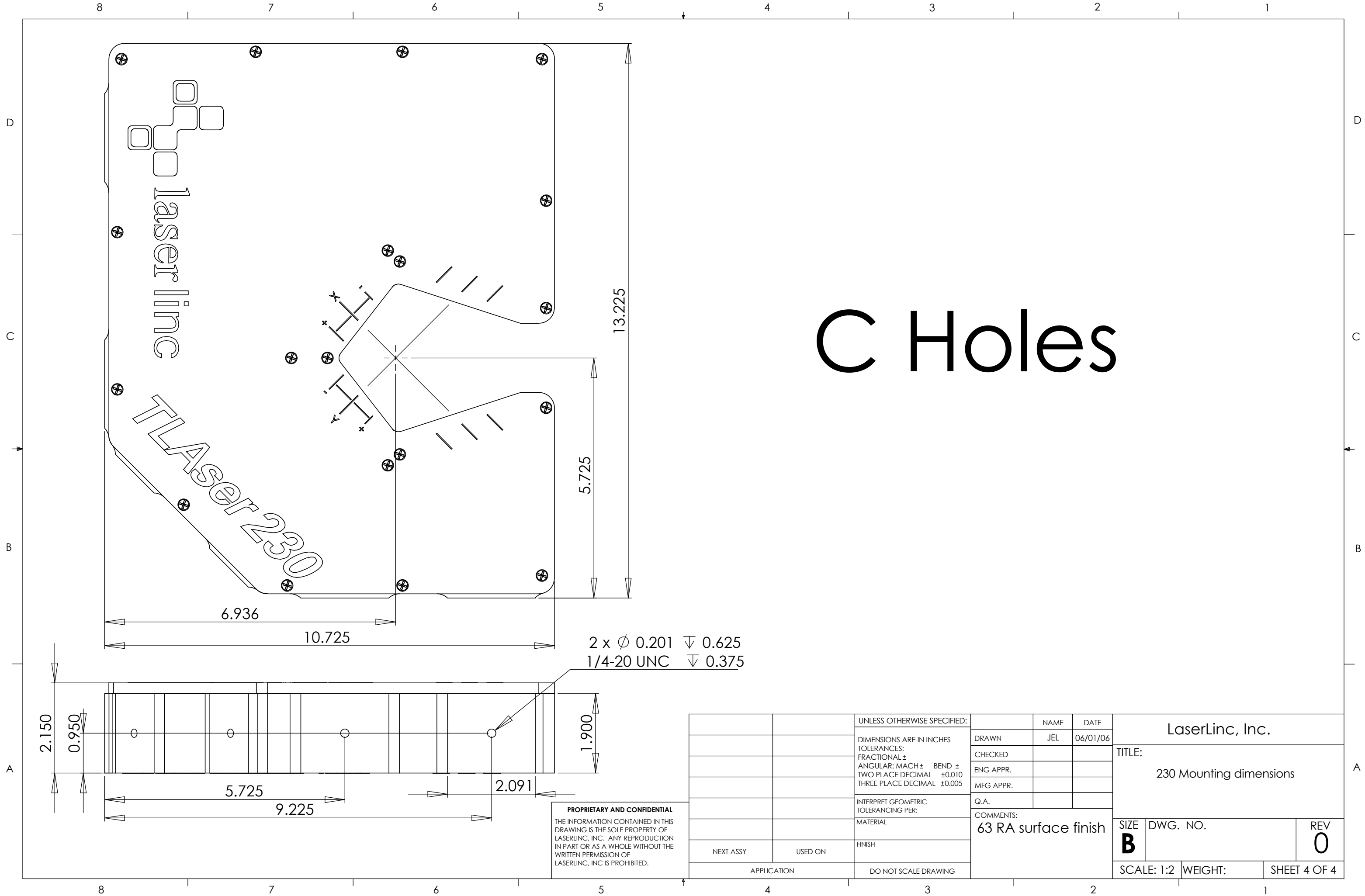

C Holes

PROPRIETARY AND CONFIDENTIAL
 THE INFORMATION CONTAINED IN THIS DRAWING IS THE SOLE PROPERTY OF LASERLINC, INC. ANY REPRODUCTION IN PART OR AS A WHOLE WITHOUT THE WRITTEN PERMISSION OF LASERLINC, INC IS PROHIBITED.

		UNLESS OTHERWISE SPECIFIED:				LaserLinc, Inc.	
		DIMENSIONS ARE IN INCHES		DRAWN	JEL	DATE	06/01/06
		TOLERANCES:		CHECKED		TITLE:	
		FRACTIONAL \pm		ENG APPR.		230 Mounting dimensions	
		ANGULAR: MACH \pm		MFG APPR.			
		BEND \pm		Q.A.			
		TWO PLACE DECIMAL ± 0.010		COMMENTS:			
		THREE PLACE DECIMAL ± 0.005		63 RA surface finish			
		INTERPRET GEOMETRIC TOLERANCING PER:		SIZE		DWG. NO.	
		MATERIAL		B			
		FINISH		REV		0	
NEXT ASSY	USED ON	DO NOT SCALE DRAWING		SCALE: 1:2		WEIGHT:	
						SHEET 4 OF 4	