

8 7 6 5 4 3 2 1

D
C
B
A

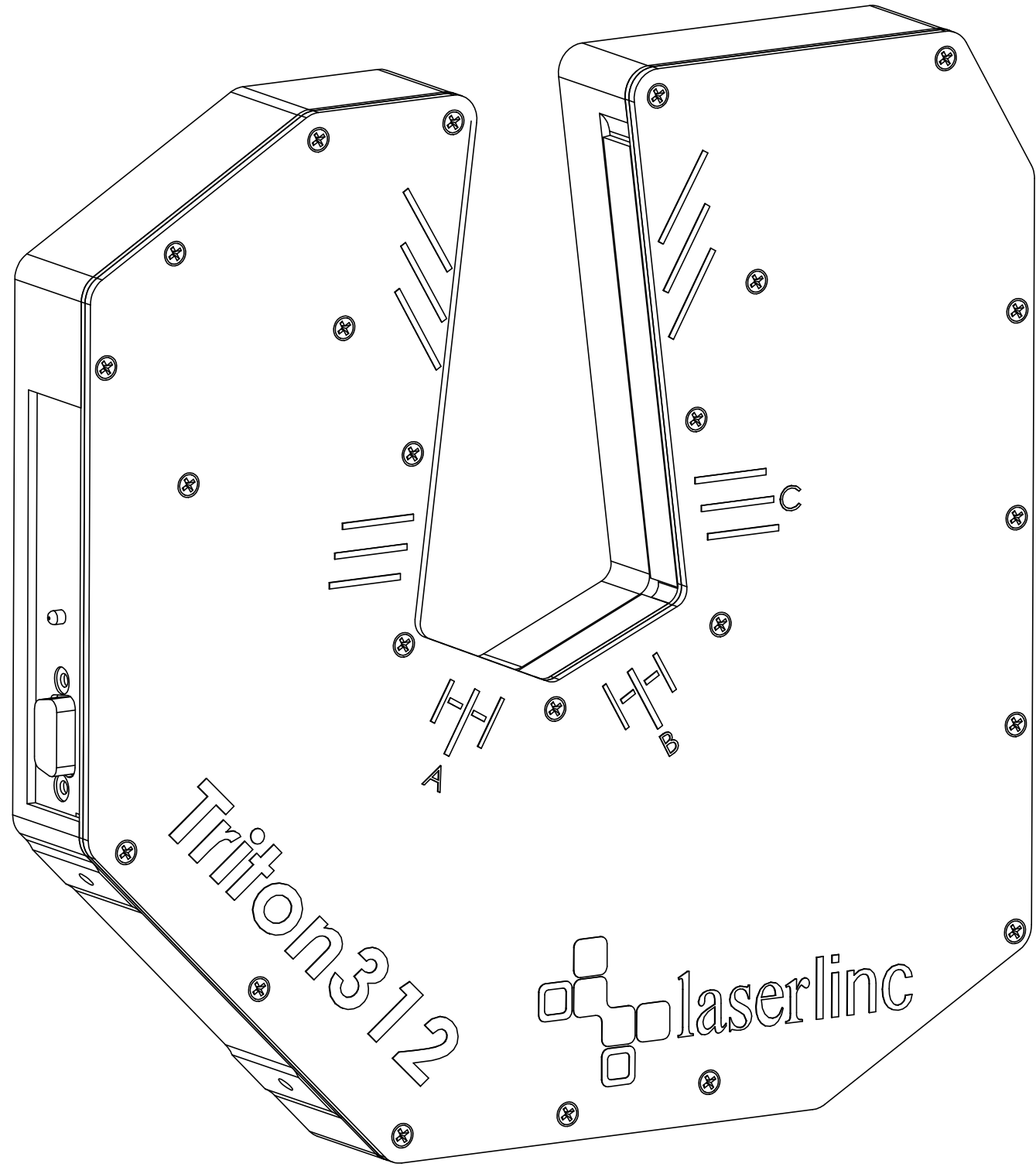

312 Gauge Mounting Configurations

Dimensions are in inches

PROPRIETARY AND CONFIDENTIAL
 THE INFORMATION CONTAINED IN THIS DRAWING IS THE SOLE PROPERTY OF LASERLINC, INC. ANY REPRODUCTION IN PART OR AS A WHOLE WITHOUT THE WRITTEN PERMISSION OF LASERLINC, INC IS PROHIBITED.

		UNLESS OTHERWISE SPECIFIED:		NAME	DATE	LaserLinc, Inc.	
		DIMENSIONS ARE IN INCHES TOLERANCES: FRACTIONAL ± ANGULAR: MACH ± BEND ± TWO PLACE DECIMAL ±0.010 THREE PLACE DECIMAL ±0.005		DRAWN	JEL	06/05/06	TITLE: 312 Mounting configurations
				CHECKED			
				ENG APPR.			
				MFG APPR.			
		INTERPRET GEOMETRIC TOLERANCING PER:		Q.A.			SIZE B
		MATERIAL		COMMENTS: 63 RA surface finish			
NEXT ASSY	USED ON	FINISH					REV 0
APPLICATION		DO NOT SCALE DRAWING					SCALE: 3:4
							WEIGHT:
							SHEET 1 OF 5

8 7 6 5 4 3 2 1

A Hole Dimensions

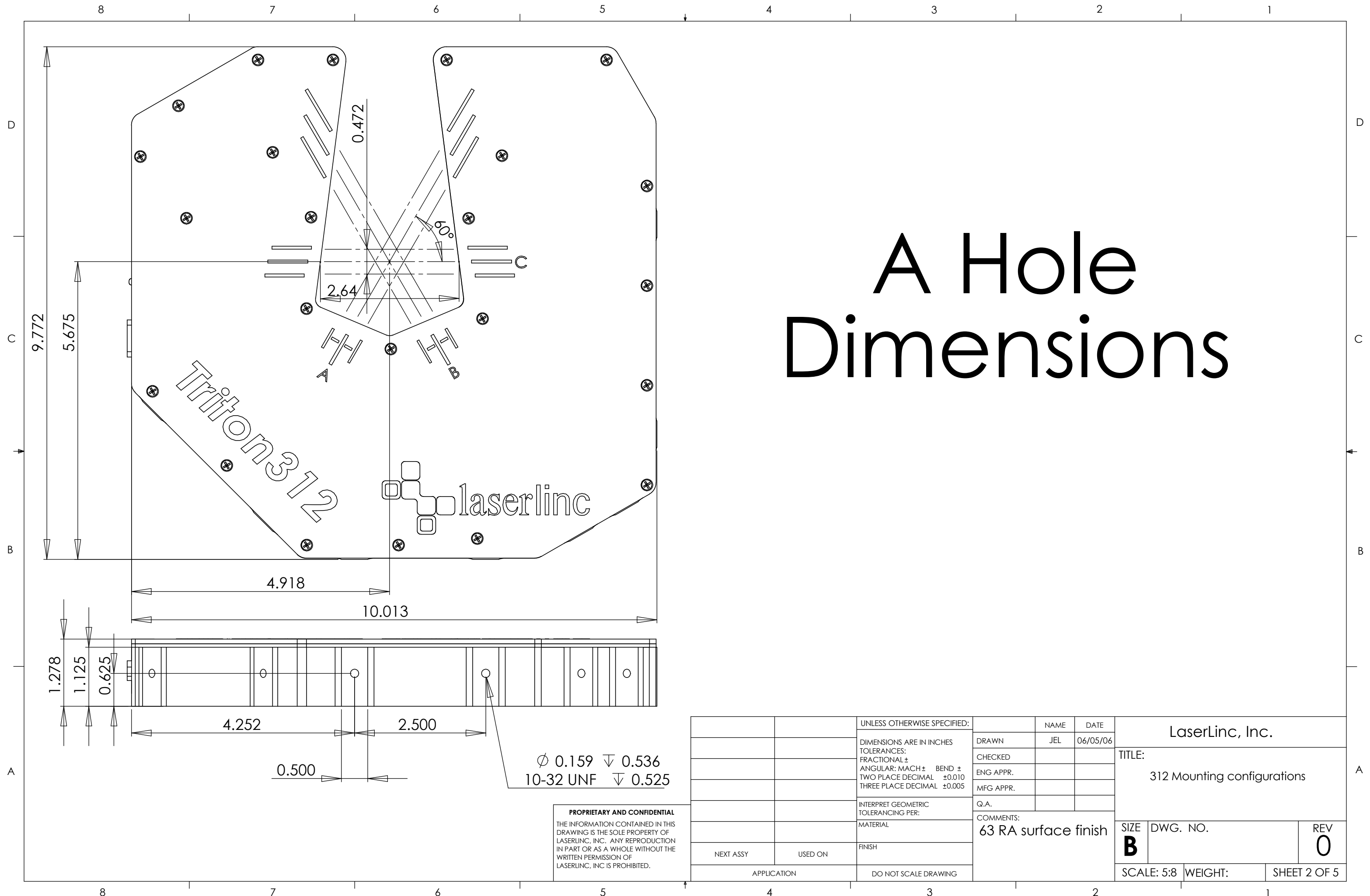

PROPRIETARY AND CONFIDENTIAL
 THE INFORMATION CONTAINED IN THIS DRAWING IS THE SOLE PROPERTY OF LASERLINC, INC. ANY REPRODUCTION IN PART OR AS A WHOLE WITHOUT THE WRITTEN PERMISSION OF LASERLINC, INC IS PROHIBITED.

		UNLESS OTHERWISE SPECIFIED:		NAME	DATE	LaserLinc, Inc.	
		DIMENSIONS ARE IN INCHES		DRAWN	JEL	06/05/06	TITLE: 312 Mounting configurations
		TOLERANCES:		CHECKED			
		FRACTIONAL ±		ENG APPR.			
		ANGULAR: MACH ± BEND ±		MFG APPR.			
		TWO PLACE DECIMAL ±0.010		Q.A.			SIZE B
		THREE PLACE DECIMAL ±0.005		COMMENTS:	63 RA surface finish		
		INTERPRET GEOMETRIC TOLERANCING PER:					REV 0
		MATERIAL					SCALE: 5:8
		FINISH					WEIGHT:
NEXT ASSY	USED ON	DO NOT SCALE DRAWING					SHEET 2 OF 5

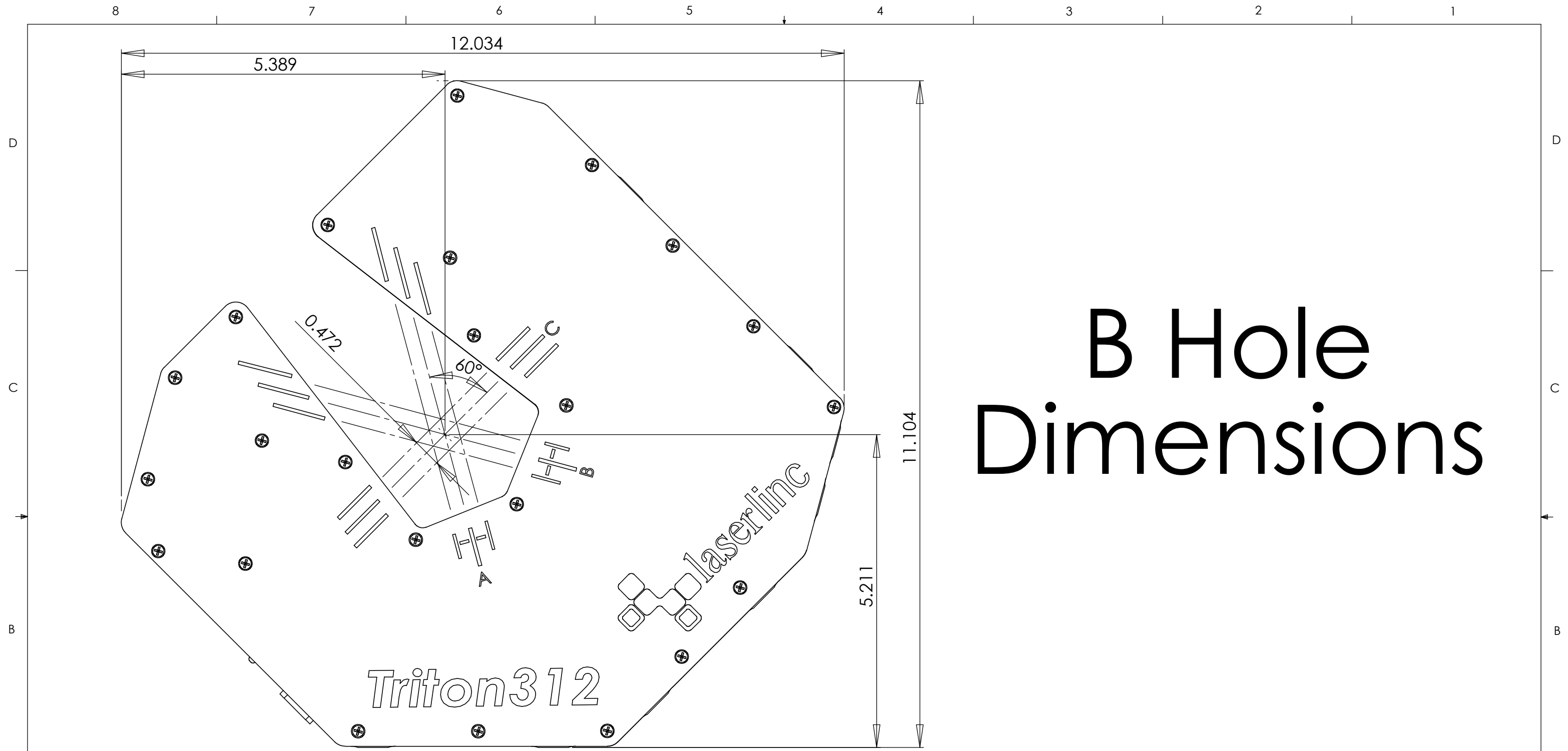

B Hole Dimensions

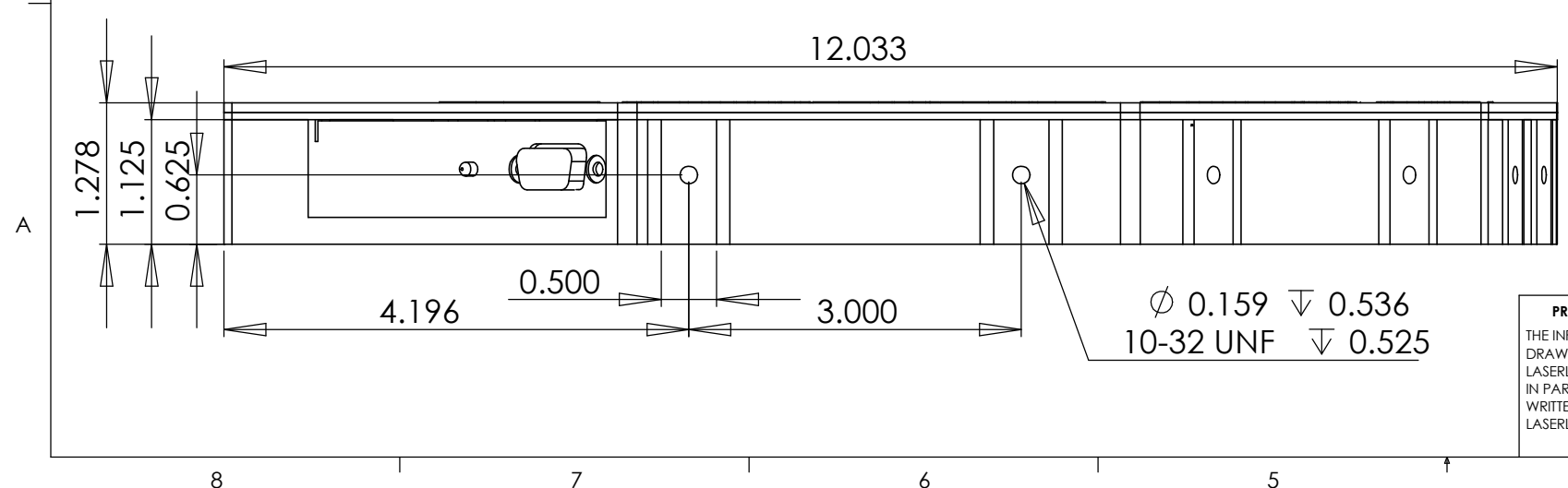

PROPRIETARY AND CONFIDENTIAL
 THE INFORMATION CONTAINED IN THIS DRAWING IS THE SOLE PROPERTY OF LASERLINC, INC. ANY REPRODUCTION IN PART OR AS A WHOLE WITHOUT THE WRITTEN PERMISSION OF LASERLINC, INC IS PROHIBITED.

UNLESS OTHERWISE SPECIFIED:	
DIMENSIONS ARE IN INCHES	
TOLERANCES:	
FRACTIONAL ±	
ANGULAR: MACH ± BEND ±	
TWO PLACE DECIMAL ±0.010	
THREE PLACE DECIMAL ±0.005	
INTERPRET GEOMETRIC TOLERANCING PER:	
MATERIAL	
FINISH	
DO NOT SCALE DRAWING	

NAME	DATE
DRAWN	JEL 06/05/06
CHECKED	
ENG APPR.	
MFG APPR.	
Q.A.	
COMMENTS:	
63 RA surface finish	

LaserLinc, Inc.		
TITLE:		
312 Mounting configurations		
SIZE	DWG. NO.	REV
B		0
SCALE: 5:8	WEIGHT:	SHEET 3 OF 5

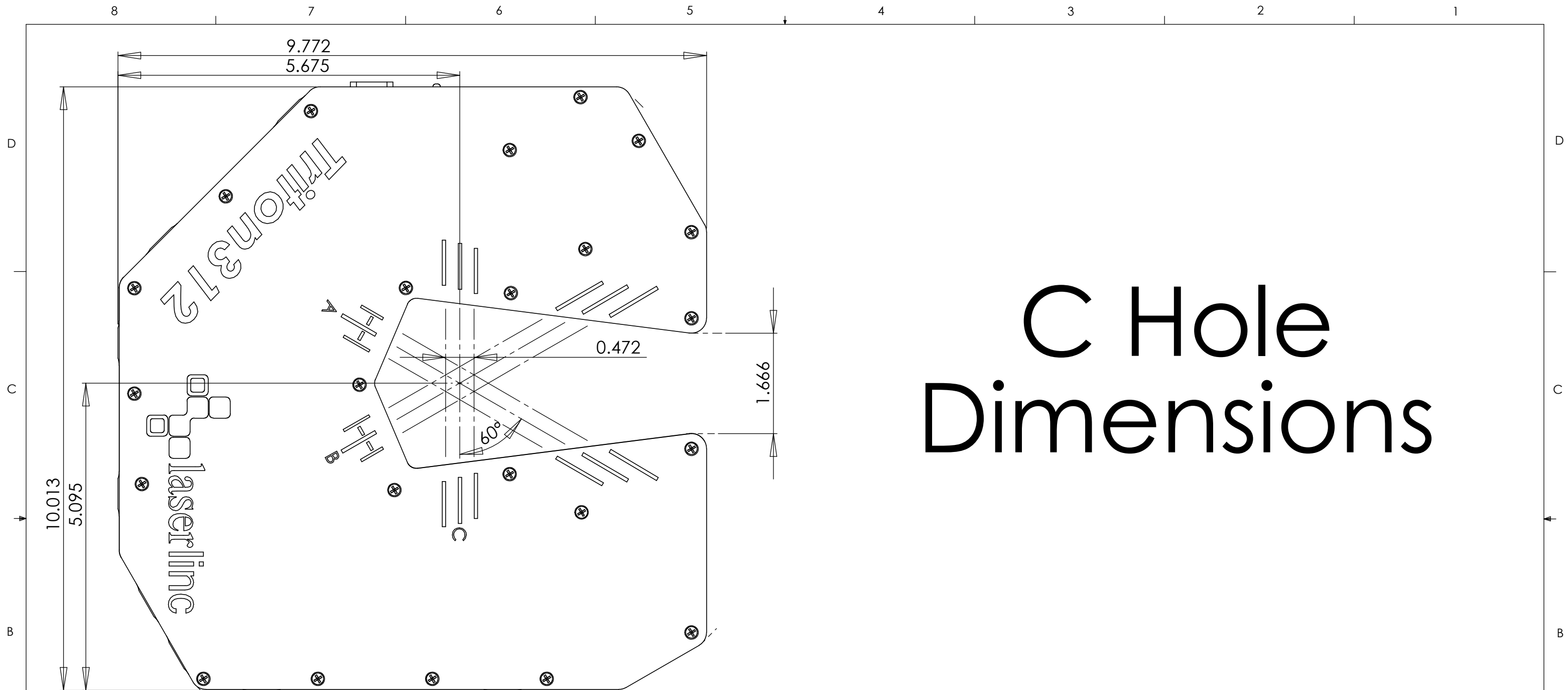

C Hole Dimensions

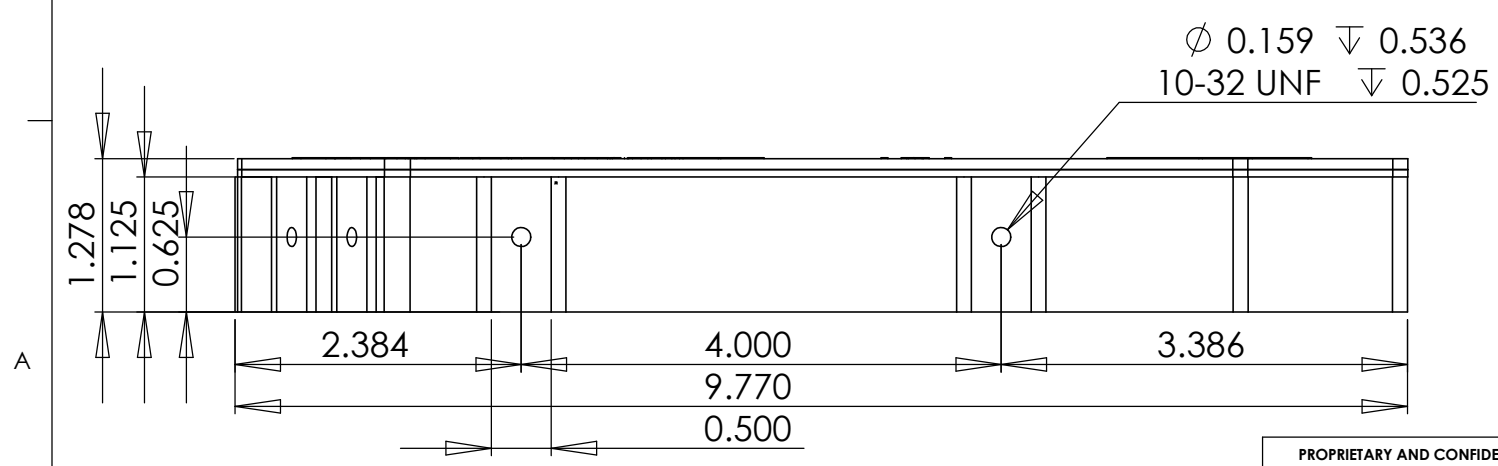

PROPRIETARY AND CONFIDENTIAL
 THE INFORMATION CONTAINED IN THIS DRAWING IS THE SOLE PROPERTY OF LASERLINC, INC. ANY REPRODUCTION IN PART OR AS A WHOLE WITHOUT THE WRITTEN PERMISSION OF LASERLINC, INC IS PROHIBITED.

		UNLESS OTHERWISE SPECIFIED:		NAME	DATE	LaserLinc, Inc.	
		DIMENSIONS ARE IN INCHES		DRAWN	JEL	06/05/06	TITLE: 312 Mounting configurations
		TOLERANCES:		CHECKED			
		FRACTIONAL ±		ENG APPR.			
		ANGULAR: MACH ± BEND ±		MFG APPR.			
		TWO PLACE DECIMAL ±0.010		Q.A.			SIZE B
		THREE PLACE DECIMAL ±0.005		COMMENTS:	63 RA surface finish		
		INTERPRET GEOMETRIC TOLERANCING PER:					REV 0
		MATERIAL					SCALE: 5:8
		FINISH					WEIGHT:
NEXT ASSY	USED ON	DO NOT SCALE DRAWING					SHEET 4 OF 5

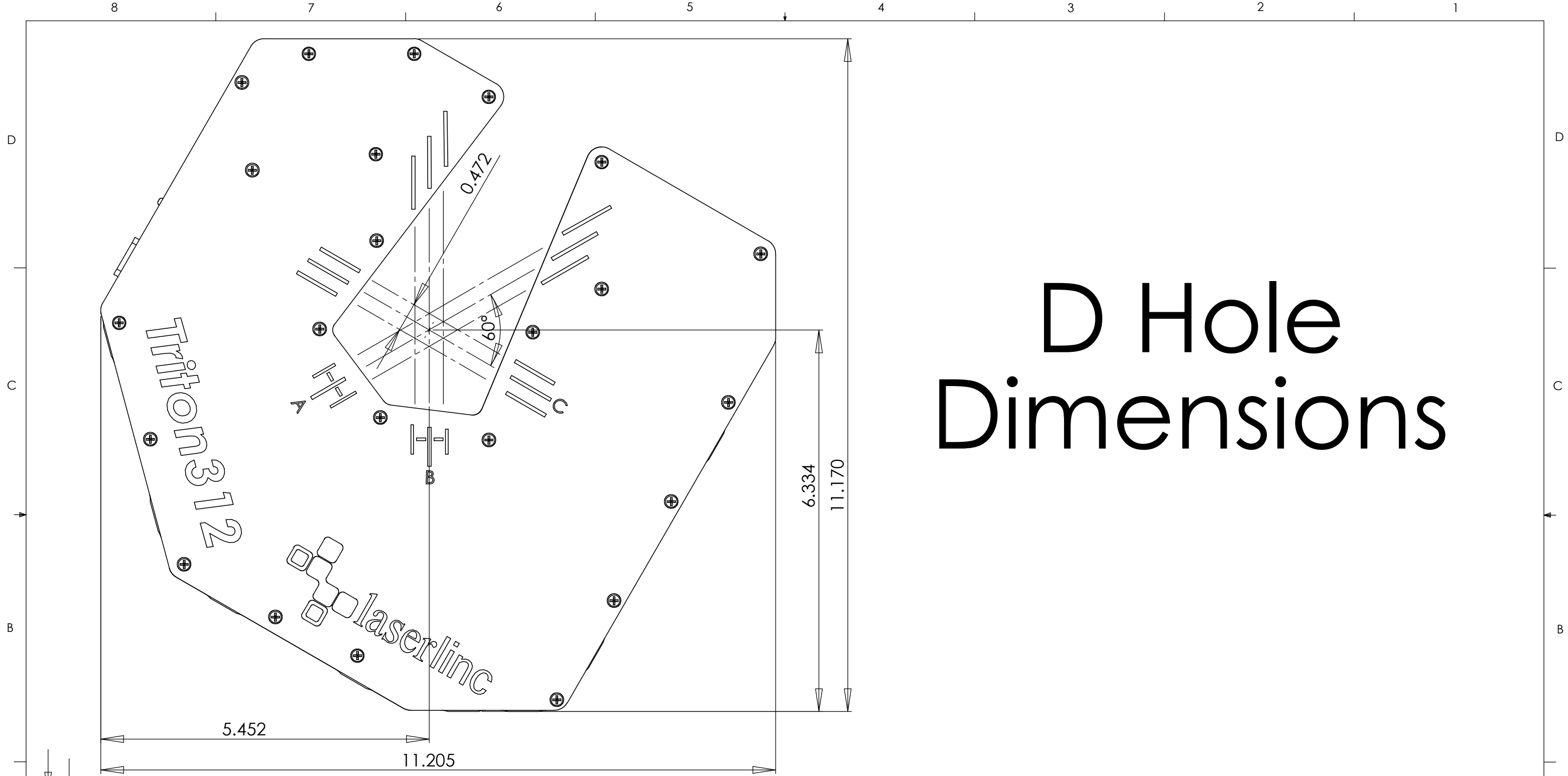

D Hole Dimensions

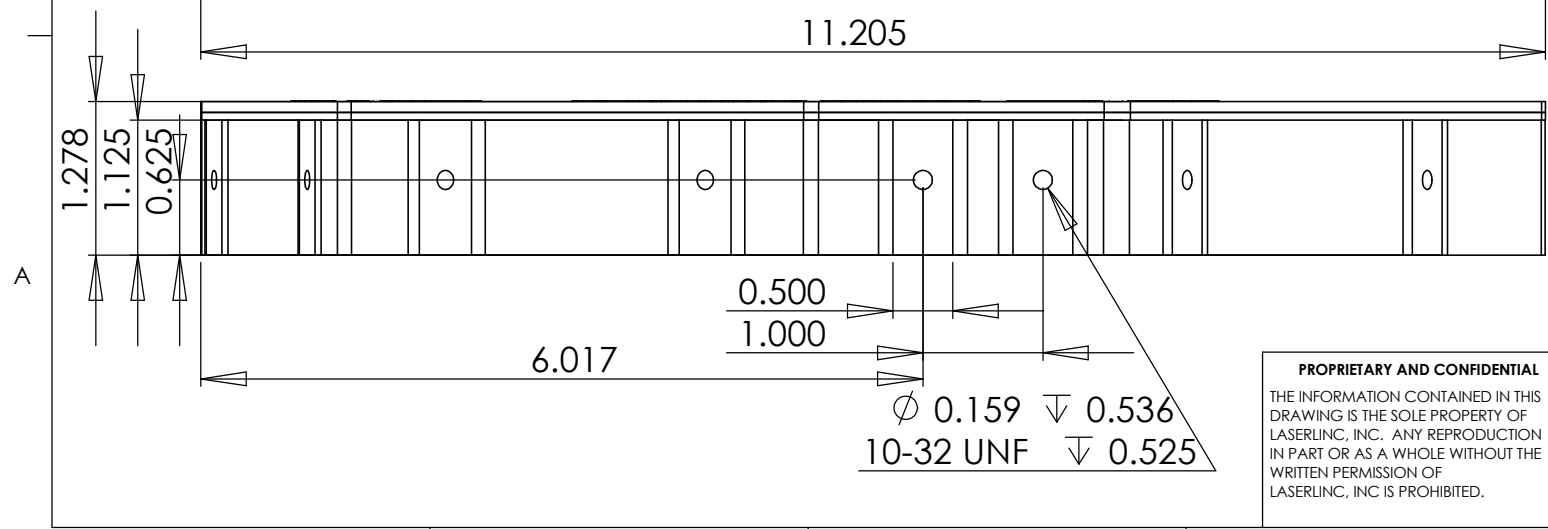

PROPRIETARY AND CONFIDENTIAL
 THE INFORMATION CONTAINED IN THIS DRAWING IS THE SOLE PROPERTY OF LASERLINC, INC. ANY REPRODUCTION IN PART OR AS A WHOLE WITHOUT THE WRITTEN PERMISSION OF LASERLINC, INC IS PROHIBITED.

		UNLESS OTHERWISE SPECIFIED:		NAME		DATE		LaserLinc, Inc.	
		DIMENSIONS ARE IN INCHES		DRAWN		JEL		06/05/06	
		TOLERANCES:		CHECKED				TITLE:	
		FRACTIONAL ±		ENG APPR.				312 Mounting configurations	
		ANGULAR: MACH ± BEND ±		MFG APPR.				Q.A.	
		TWO PLACE DECIMAL ±0.010		COMMENTS:		63 RA surface finish		SIZE	
		THREE PLACE DECIMAL ±0.005		FINISH				DWG. NO.	
NEXT ASSY		USED ON		DO NOT SCALE DRAWING				REV	
APPLICATION						SCALE: 5:8		WEIGHT:	
								SHEET 5 OF 5	