

8 7 6 5 4 3 2 1

D  
C  
B  
A

D  
C  
B  
A

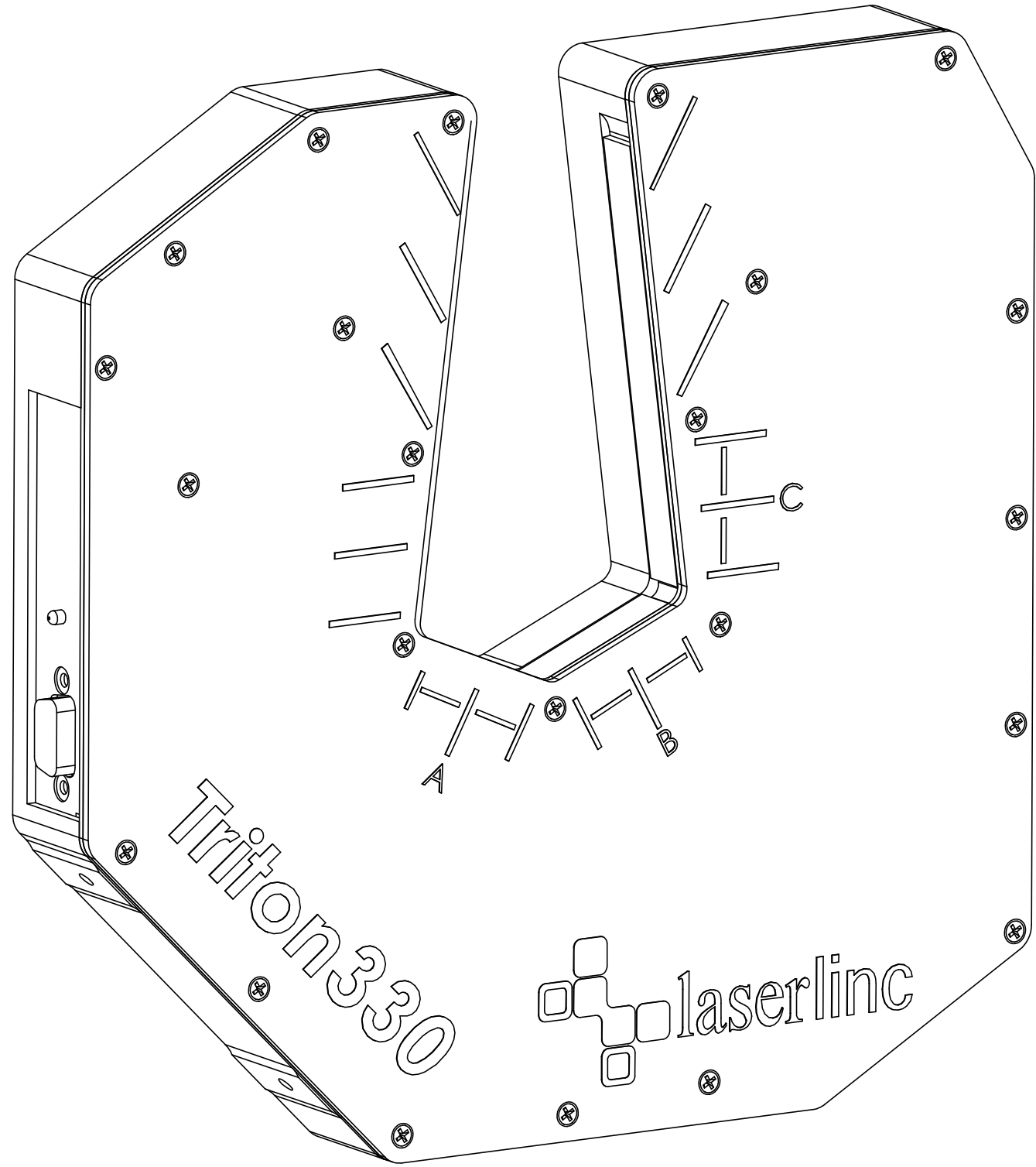

# 330 Gauge Mounting Configurations

Dimensions are in inches

**PROPRIETARY AND CONFIDENTIAL**  
 THE INFORMATION CONTAINED IN THIS DRAWING IS THE SOLE PROPERTY OF LASERLINC, INC. ANY REPRODUCTION IN PART OR AS A WHOLE WITHOUT THE WRITTEN PERMISSION OF LASERLINC, INC IS PROHIBITED.

		UNLESS OTHERWISE SPECIFIED:		NAME	DATE	LaserLinc, Inc.	
		DIMENSIONS ARE IN INCHES TOLERANCES: FRACTIONAL ± ANGULAR: MACH ± BEND ± TWO PLACE DECIMAL ±0.010 THREE PLACE DECIMAL ±0.005		DRAWN	JEL	06/05/06	TITLE: 330 Mounting configurations
				CHECKED			
				ENG APPR.			
				MFG APPR.			
		INTERPRET GEOMETRIC TOLERANCING PER:		Q.A.			SIZE <b>B</b>
		MATERIAL		COMMENTS: 63 RA surface finish			
NEXT ASSY	USED ON	FINISH					REV <b>0</b>
APPLICATION		DO NOT SCALE DRAWING					SCALE: 3:4
							WEIGHT:
							SHEET 1 OF 5

8 7 6 5 4 3 2 1

# A Hole Dimensions

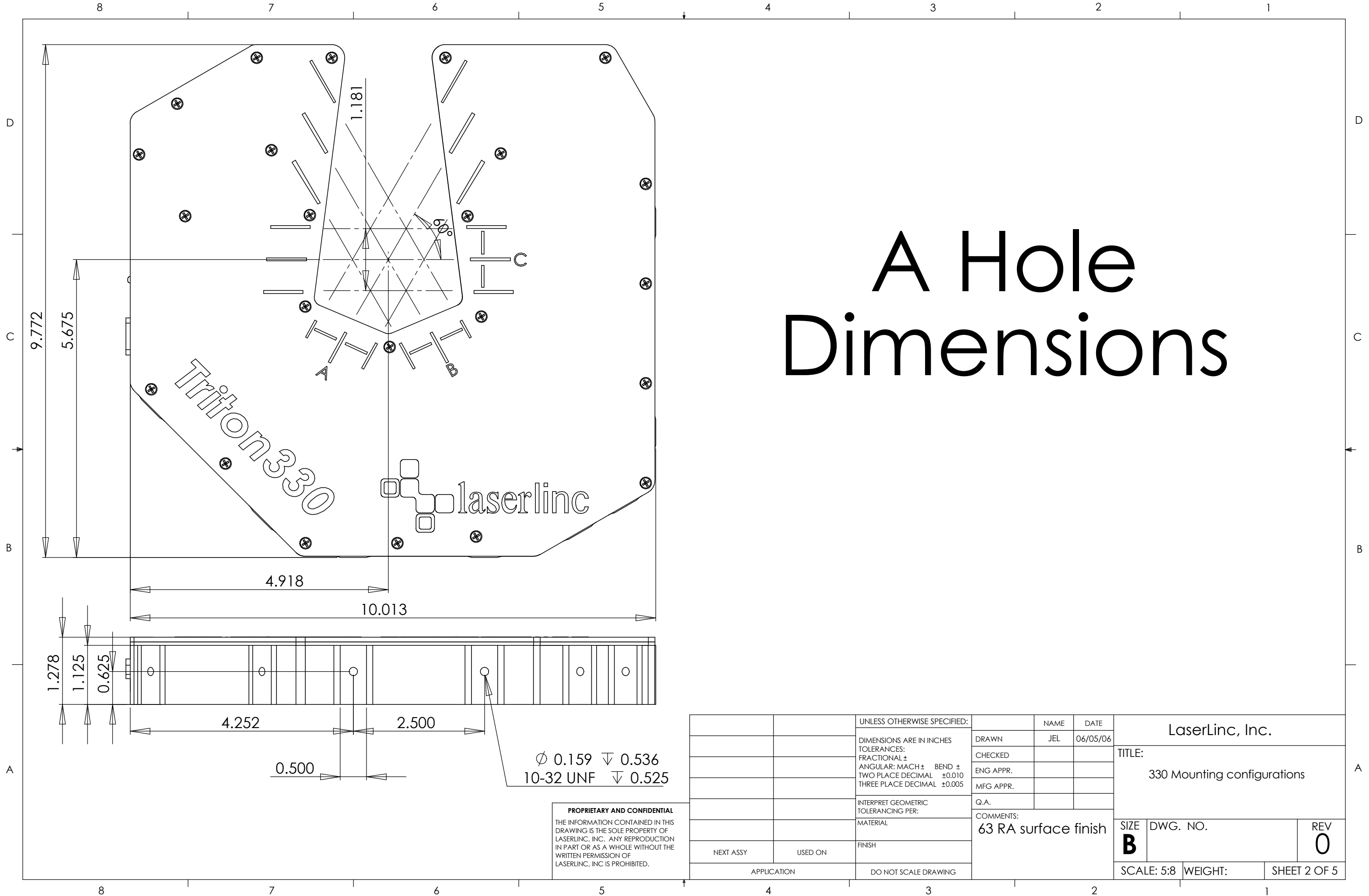

**PROPRIETARY AND CONFIDENTIAL**  
 THE INFORMATION CONTAINED IN THIS DRAWING IS THE SOLE PROPERTY OF LASERLINC, INC. ANY REPRODUCTION IN PART OR AS A WHOLE WITHOUT THE WRITTEN PERMISSION OF LASERLINC, INC IS PROHIBITED.

		UNLESS OTHERWISE SPECIFIED:		NAME		DATE		LaserLinc, Inc.	
		DIMENSIONS ARE IN INCHES		DRAWN		JEL		06/05/06	
		TOLERANCES:		CHECKED				TITLE:	
		FRACTIONAL ±		ENG APPR.				330 Mounting configurations	
		ANGULAR: MACH ± BEND ±		MFG APPR.				Q.A.	
		TWO PLACE DECIMAL ±0.010		COMMENTS:		63 RA surface finish		SIZE DWG. NO. REV	
		THREE PLACE DECIMAL ±0.005		FINISH				<b>B</b> <b>0</b>	
NEXT ASSY		USED ON		DO NOT SCALE DRAWING		SCALE: 5:8		WEIGHT: SHEET 2 OF 5	

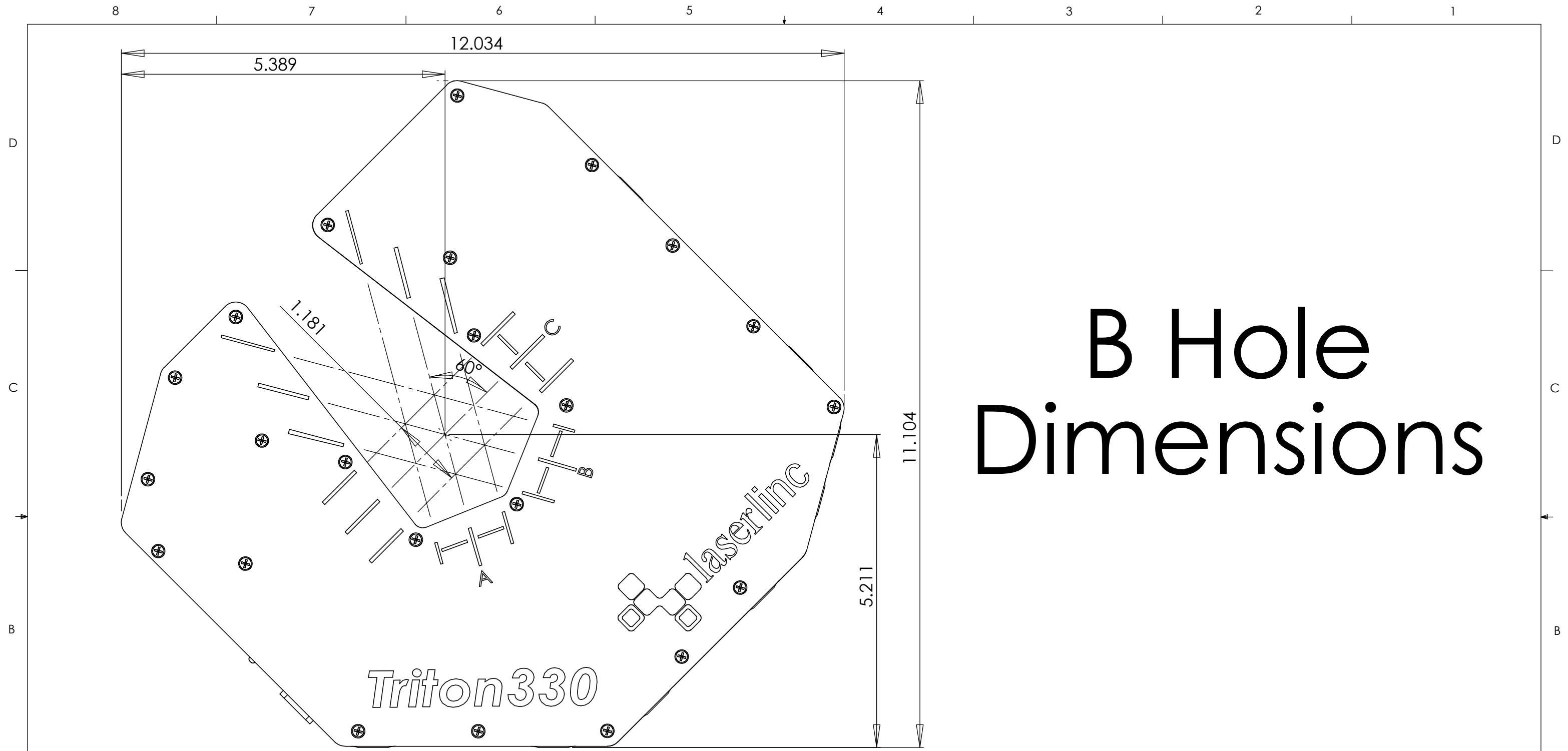

# B Hole Dimensions

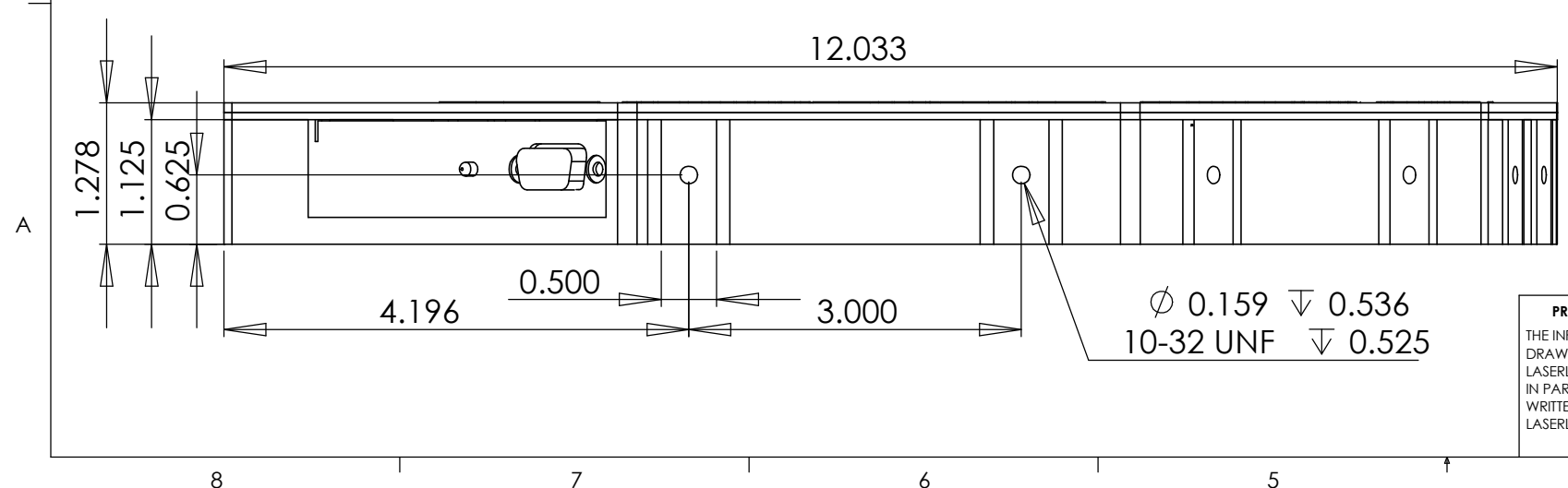

**PROPRIETARY AND CONFIDENTIAL**  
 THE INFORMATION CONTAINED IN THIS DRAWING IS THE SOLE PROPERTY OF LASERLINC, INC. ANY REPRODUCTION IN PART OR AS A WHOLE WITHOUT THE WRITTEN PERMISSION OF LASERLINC, INC IS PROHIBITED.

UNLESS OTHERWISE SPECIFIED:		NAME	DATE	LaserLinc, Inc.	
DIMENSIONS ARE IN INCHES		DRAWN	JEL	06/05/06	TITLE: 330 Mounting configurations
TOLERANCES:		CHECKED			
FRACTIONAL ±		ENG APPR.			
ANGULAR: MACH ± BEND ±		MFG APPR.			
TWO PLACE DECIMAL ±0.010		Q.A.			SIZE DWG. NO. REV <b>B</b> <b>0</b>
THREE PLACE DECIMAL ±0.005		COMMENTS:	63 RA surface finish		
INTERPRET GEOMETRIC TOLERANCING PER:				SCALE: 5:8	WEIGHT:
MATERIAL				SHEET 3 OF 5	
FINISH					
DO NOT SCALE DRAWING					

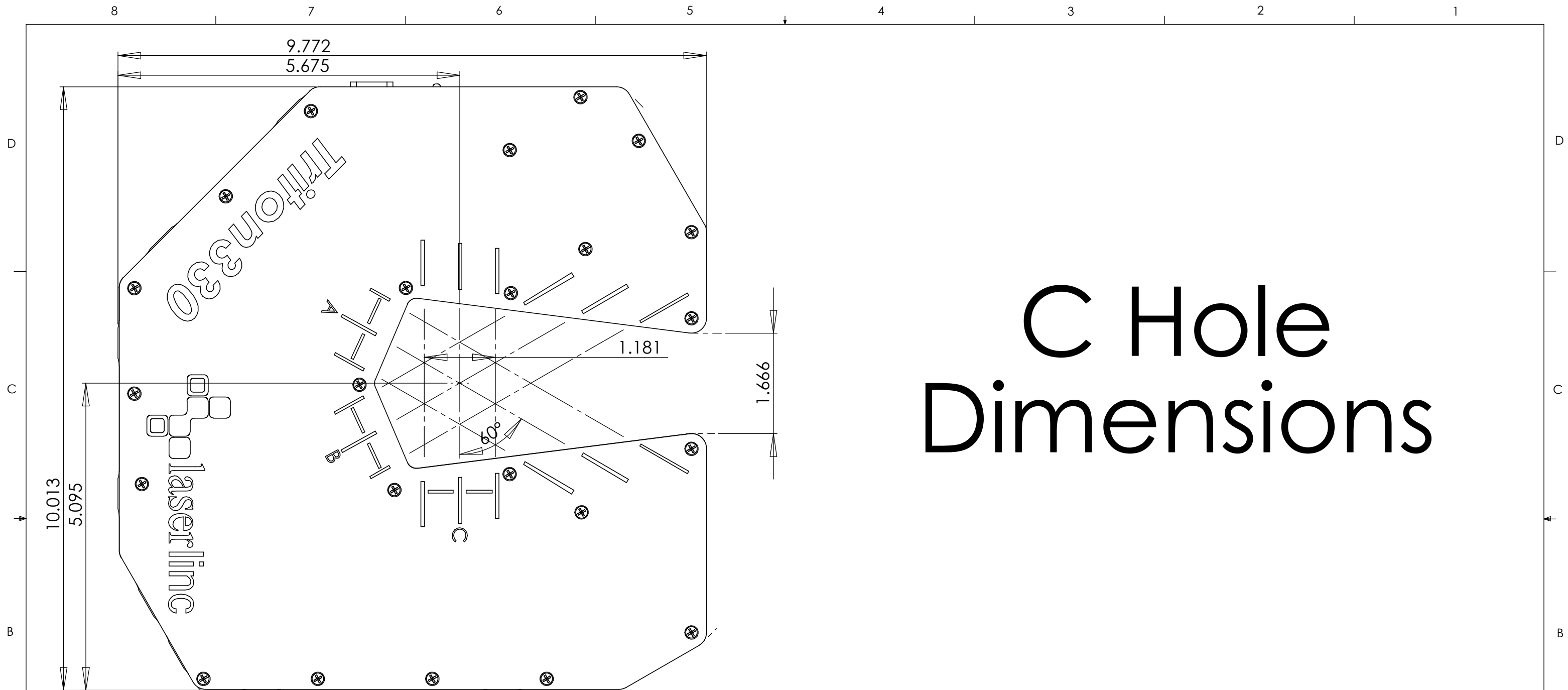

# C Hole Dimensions

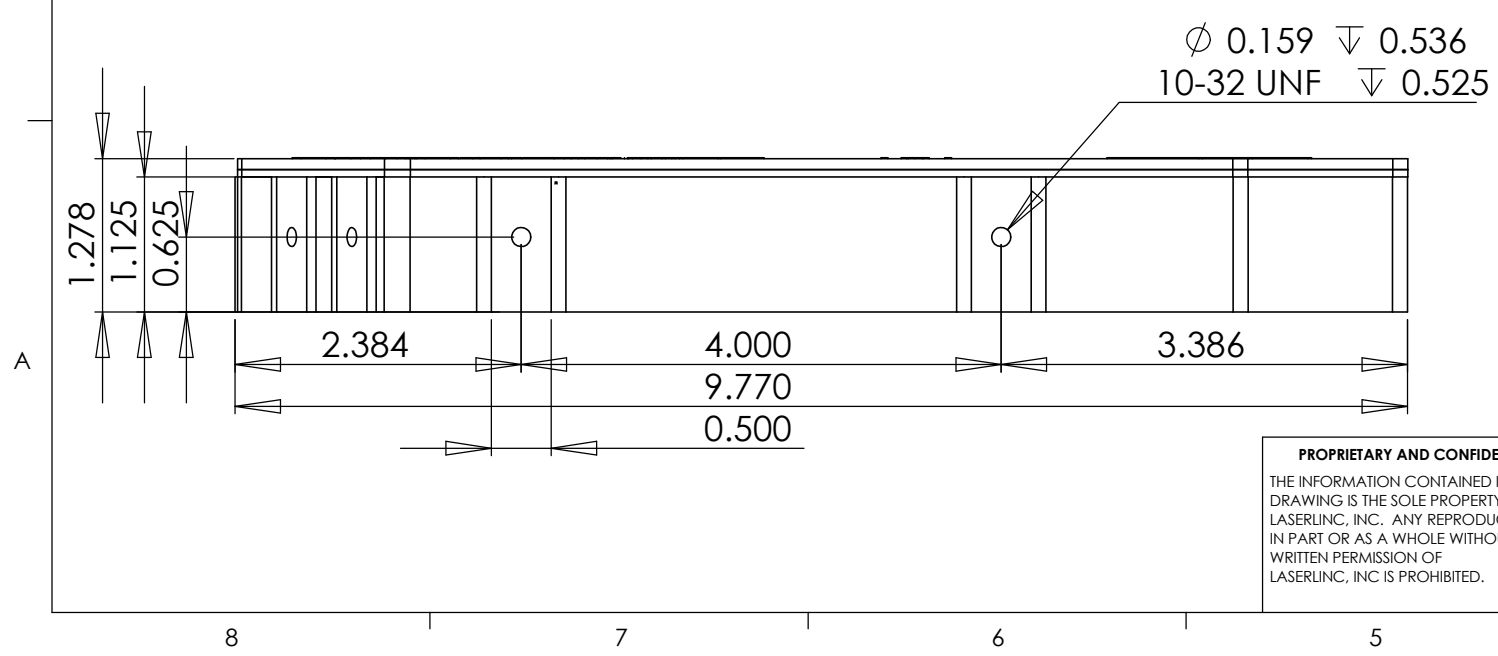

**PROPRIETARY AND CONFIDENTIAL**  
 THE INFORMATION CONTAINED IN THIS DRAWING IS THE SOLE PROPERTY OF LASERLINC, INC. ANY REPRODUCTION IN PART OR AS A WHOLE WITHOUT THE WRITTEN PERMISSION OF LASERLINC, INC IS PROHIBITED.

		UNLESS OTHERWISE SPECIFIED:		NAME		DATE		LaserLinc, Inc.	
		DIMENSIONS ARE IN INCHES		DRAWN		JEL		06/05/06	
		TOLERANCES:		CHECKED				TITLE:	
		FRACTIONAL ±		ENG APPR.				330 Mounting configurations	
		ANGULAR: MACH ± BEND ±		MFG APPR.				SIZE	
		TWO PLACE DECIMAL ±0.010		Q.A.				DWG. NO.	
		THREE PLACE DECIMAL ±0.005		COMMENTS:		63 RA surface finish		REV	
		INTERPRET GEOMETRIC TOLERANCING PER:		NEXT ASSY		USED ON		0	
		MATERIAL		APPLICATION		DO NOT SCALE DRAWING		SCALE: 5:8	
		FINISH						WEIGHT:	
								SHEET 4 OF 5	

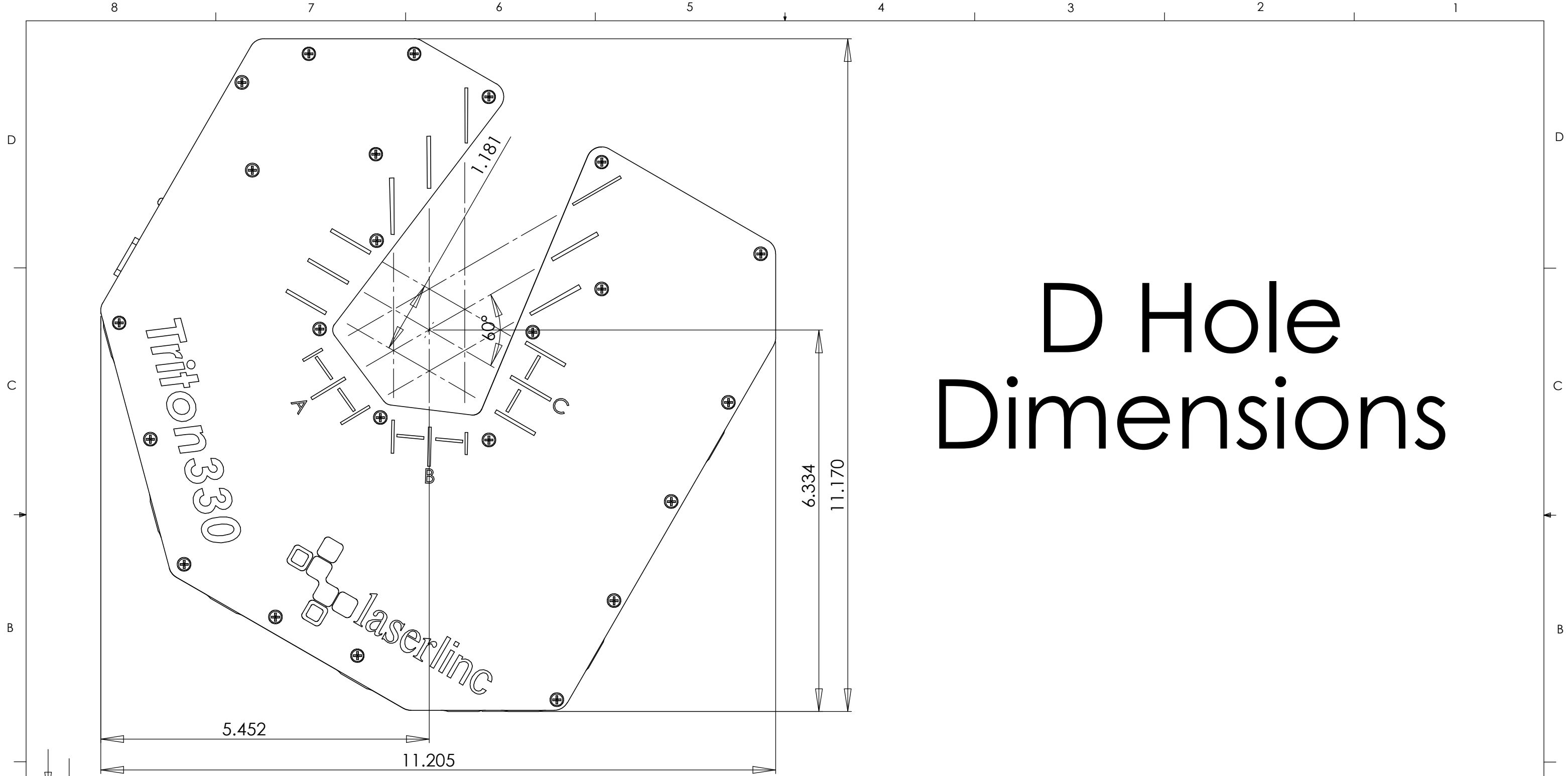

# D Hole Dimensions

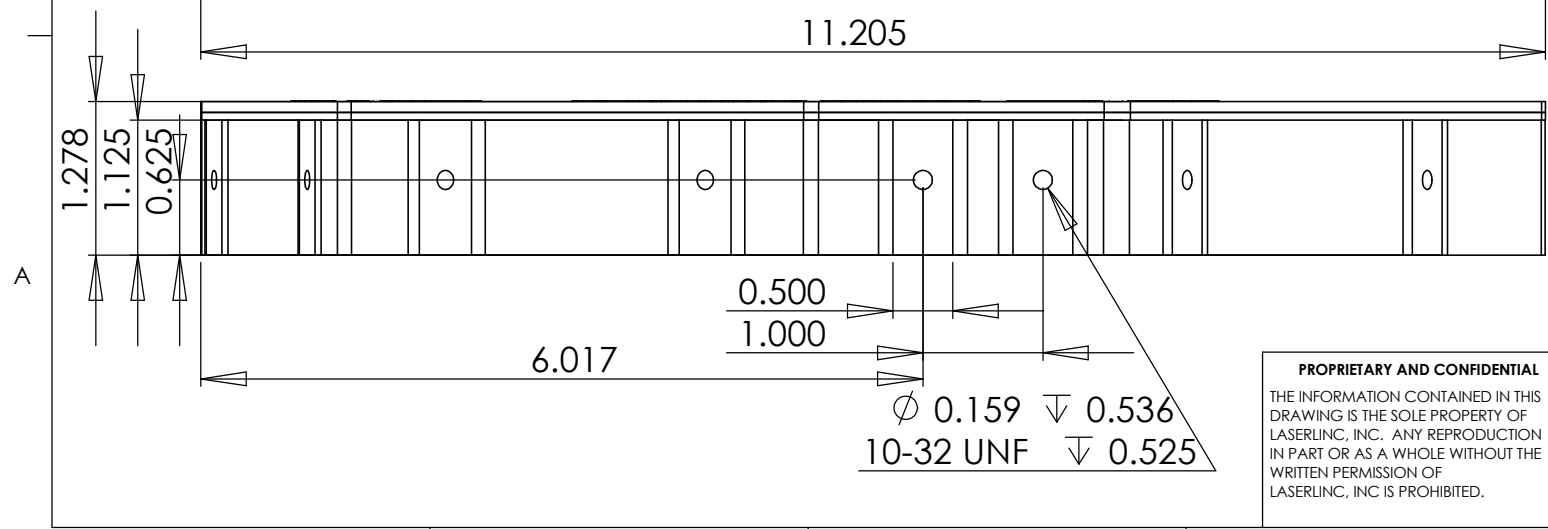

**PROPRIETARY AND CONFIDENTIAL**  
 THE INFORMATION CONTAINED IN THIS DRAWING IS THE SOLE PROPERTY OF LASERLINC, INC. ANY REPRODUCTION IN PART OR AS A WHOLE WITHOUT THE WRITTEN PERMISSION OF LASERLINC, INC IS PROHIBITED.

		UNLESS OTHERWISE SPECIFIED:				LaserLinc, Inc.	
		DIMENSIONS ARE IN INCHES		DRAWN	JEL	06/05/06	TITLE: 330 Mounting configurations
		TOLERANCES:		CHECKED			
		FRACTIONAL ±		ENG APPR.			
		ANGULAR: MACH ± BEND ±		MFG APPR.			
		TWO PLACE DECIMAL ±0.010		Q.A.			SIZE <b>B</b>
		THREE PLACE DECIMAL ±0.005		COMMENTS: 63 RA surface finish		DWG. NO.	
		INTERPRET GEOMETRIC TOLERANCING PER:				SCALE: 5:8	
		MATERIAL				WEIGHT:	
		FINISH				SHEET 5 OF 5	
NEXT ASSY	USED ON	DO NOT SCALE DRAWING					