

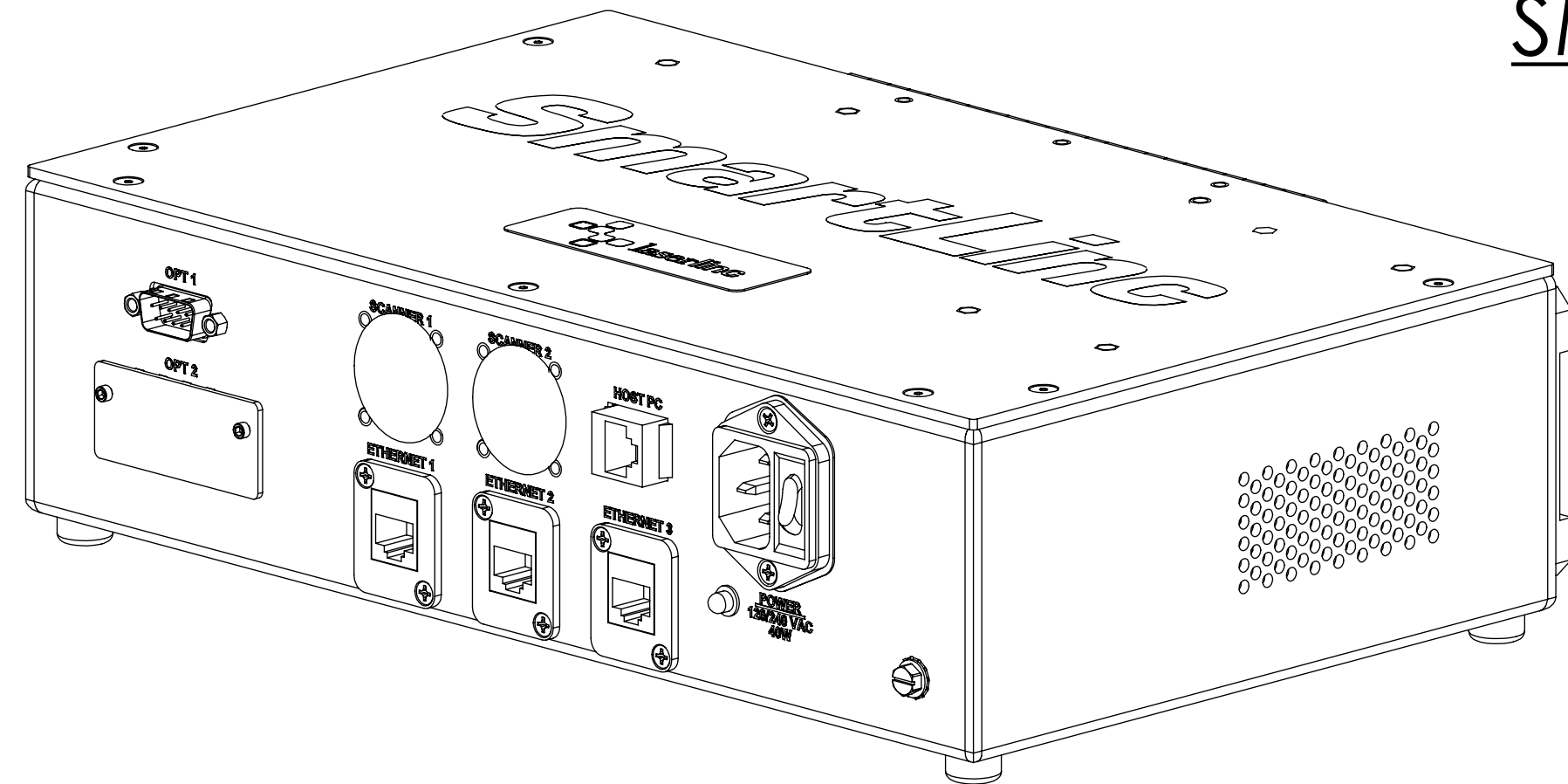

REVISIONS

ZONE	REV.	DESCRIPTION	DATE	APPROVED
	A	CHECK-IN	8/18/2022	EMM

# SMARTLINC PROCESSOR STAND CONFIG OVERALLS



**INDEX**  
 (1) COVER PAGE  
 (2) DIMENSIONS

<b>GENERAL FINISH NOTE</b> DE-BURR AND BREAK ALL SHARP EDGES BEFORE FINISH AND/OR SHIPPING	UNLESS OTHERWISE SPECIFIED: DIMENSIONS ARE IN INCHES TOLERANCES: ANGLES ±.25° TWO PLACE DECIMAL ±0.010 THREE PLACE DECIMAL ±0.005 FOUR PLACE DECIMAL ±0.0005 UNMARKED FILLETS/CHAMFER .06 DE-BURR ALL PARTS	NAME	DATE	 LASERLINC, INC. PHONE: 888-707-4892 INFO@LASERLINC.COM WWW.LASERLINC.COM
		DRAWN BY:	EMM	
PROPRIETARY AND CONFIDENTIAL  THE INFORMATION CONTAINED IN THIS DRAWING IS THE SOLE PROPERTY OF LASERLINC, INC. ANY REPRODUCTION IN PART OR AS A WHOLE WITHOUT THE WRITTEN PERMISSION OF LASERLINC, INC. IS PROHIBITED.	INTERPRET GEOMETRIC TOLERANCING PER: ASME Y14.5	TITLE: 0401-0026-00 SMARTLINC PROCESSOR BOX - STANDARD CONFIG OVERALLS		SIZE <b>B</b>
MATERIAL  FINISH  DO NOT SCALE DRAWING	63 RA SURFACE FINISH ALL FEATURES MUST MEET SPECIFICATION AFTER PLATING BEFORE POWDER-COAT IF PLATED OR POWDER-COATED SEE FINISH	DWG. NO. 0410-0026-00	REV <b>A</b>	
		SCALE: 2:3	SHEET 1 OF 2	

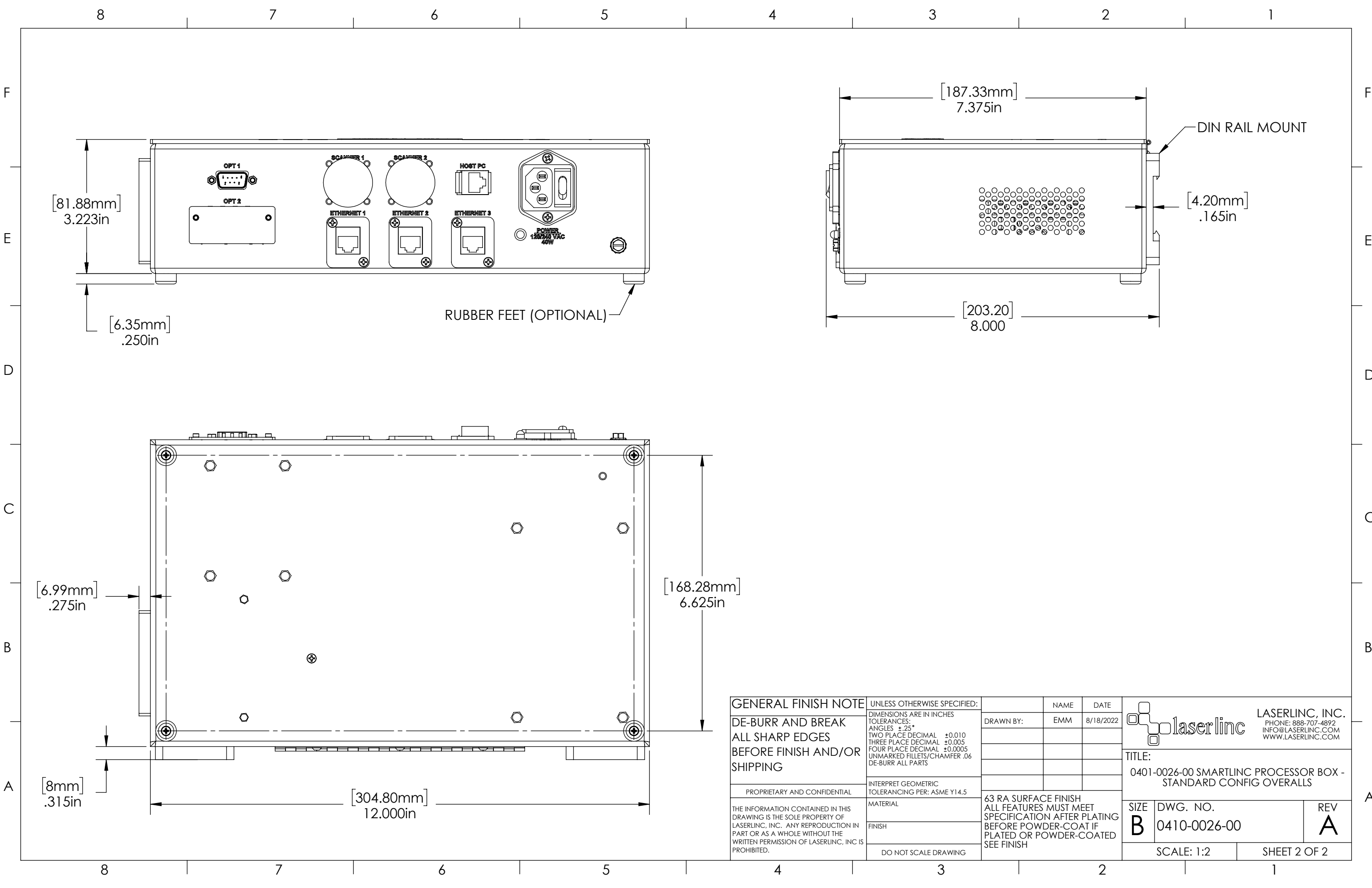

<b>GENERAL FINISH NOTE</b> DE-BURR AND BREAK ALL SHARP EDGES BEFORE FINISH AND/OR SHIPPING  PROPRIETARY AND CONFIDENTIAL  THE INFORMATION CONTAINED IN THIS DRAWING IS THE SOLE PROPERTY OF LASERLINC, INC. ANY REPRODUCTION IN PART OR AS A WHOLE WITHOUT THE WRITTEN PERMISSION OF LASERLINC, INC. IS PROHIBITED.	UNLESS OTHERWISE SPECIFIED: DIMENSIONS ARE IN INCHES TOLERANCES: ANGLES ±.25° TWO PLACE DECIMAL ±0.010 THREE PLACE DECIMAL ±0.005 FOUR PLACE DECIMAL ±0.0005 UNMARKED FILLETS/CHAMFER .06 DE-BURR ALL PARTS	NAME DATE	 <b>LASERLINC, INC.</b> PHONE: 888-707-4892 INFO@LASERLINC.COM WWW.LASERLINC.COM		
	INTERPRET GEOMETRIC TOLERANCING PER: ASME Y14.5	DRAWN BY: EMM DATE: 8/18/2022	<b>TITLE:</b> 0401-0026-00 SMARTLINC PROCESSOR BOX - STANDARD CONFIG OVERALLS		
	MATERIAL  FINISH	63 RA SURFACE FINISH ALL FEATURES MUST MEET SPECIFICATION AFTER PLATING BEFORE POWDER-COAT IF PLATED OR POWDER-COATED SEE FINISH		<b>SIZE</b> <b>B</b>	<b>DWG. NO.</b> 0410-0026-00
	DO NOT SCALE DRAWING	<b>REV</b> <b>A</b>		SCALE: 1:2	SHEET 2 OF 2