

Guide to Signal Connections



**MEASUREMENT
COMPUTING™**

Revision 3, June, 2002

© Copyright 2002, Measurement Computing Corporation

IBM, PC, and PC/AT are trademarks of International Business Machines Corp. Windows is a trademark of Microsoft Corp. All other trademarks are the property of their respective owners.

Information furnished by Measurement Computing Corp. is believed to be accurate and reliable. However, no responsibility is assumed by Measurement Computing Corporation neither for its use; nor for any infringements of patents or other rights of third parties, which may result from its use. No license is granted by implication or otherwise under any patent or copyrights of Measurement Computing Corporation.

All rights reserved. No part of this publication may be reproduced, stored in a retrieval system, or transmitted, in any form by any means, electronic, mechanical, by photocopying, recording or otherwise without the prior written permission of Measurement Computing Corporation.

Notice

Measurement Computing Corporation does not authorize any Measurement Computing Corporation product for use in life support systems and/or devices without the written approval of the President of Measurement Computing Corporation. Life support devices/systems are devices or systems which, a) are intended for surgical implantation into the body, or b) support or sustain life and whose failure to perform can be reasonably expected to result in injury. Measurement Computing Corp. products are not designed with the components required, and are not subject to the testing required to ensure a level of reliability suitable for the treatment and diagnosis of people.

TABLE OF CONTENTS

1	Analog Input Types.....	1-1
1.1	Single-Ended Inputs	1-1
1.2	Differential Inputs.....	1-2
2	System Grounds and Isolation	2-1
2.1	Ground Type Determination	2-1
2.2	Systems with Common Grounds	2-1
2.3	Systems with Common Mode (Ground Offset) Voltages.....	2-2
2.4	Small Common Mode Voltages	2-2
2.5	Large Common Mode Voltages.....	2-2
2.6	Card and Signal Source Already Have Isolated Grounds	2-2
3	Wiring Configurations	3-1
3.1	Common Ground / Single-Ended Inputs.....	3-1
3.2	Common Ground / Differential Inputs	3-1
3.3	Common Mode Voltage < $\pm 10V$ / Single-Ended Inputs.....	3-2
3.4	Common Mode Voltage < $\pm 10V$ / Differential Inputs	3-2
3.5	Isolated Grounds / Single-Ended Inputs.....	3-3
3.6	Isolated Grounds / Differential Inputs	3-4
4	Digital I/O Techniques	4-1
4.1	Pull-up & Pull-down Resistors	4-1
4.2	TTL TO Solid State Relays	4-2
4.3	Voltage Dividers.....	4-3
4.4	Low Pass Filter to De-bounce Inputs.....	4-4

1 Analog Input Types

This chapter explains how to make analog input connections to achieve the optimum performance from your board.

Prior to jumping into actual connection schemes, you should have a basic understanding of single-ended/differential inputs and system grounding/isolation. If you are already comfortable with these concepts, you may wish to skip to the next section (on wiring configurations).

The board provides 16 differential input channels or eight single-ended input channels. The theory of single-ended and differential inputs are described in the following sections.

1.1 Single-Ended Inputs

A single-ended input measures the voltage between the input signal and ground. In single-ended mode the board measures the voltage between the input channel and low-level ground (LLGND – see Figure 1-1). The single-ended input configuration requires only one physical connection (wire) per channel and allows the board to monitor more channels than the 2-wire differential configuration using the same connector and onboard multiplexer.

For clarity, the input multiplexers are not shown in the following diagrams.

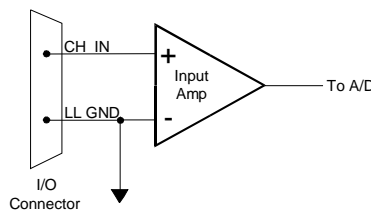

Figure 1-1. Single-Ended Input

Because the board is measuring the input voltage relative to its own LLGND, single-ended inputs are more susceptible to both electromagnetic interference (EMI) and any ground noise at the signal source. Figure 1-2 shows an input having a common mode voltage.

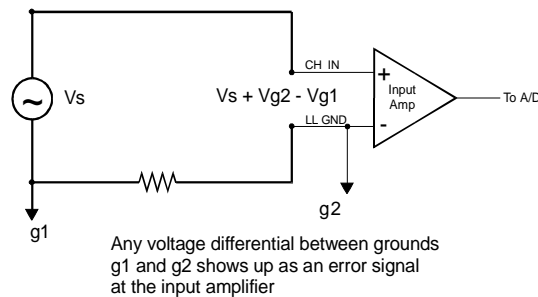

Figure 1-2. Single-Ended Input with Common Mode Voltage

1.2 Differential Inputs

Differential inputs measure the voltage between two distinct input signals. Within a certain range—called the *common mode range*—the measurement is almost independent of signal source to board ground variations. A differential input is also more immune to EMI than a single-ended one. Most EMI noise induced in one lead is also induced in the other. The input measures only the difference between the two leads, and the EMI common to both is ignored. This effect is a major reason for twisted pair wiring because the twisting ensures that both wires are subject to virtually identical external influence. Figure 1-3 shows the basic differential input configuration.

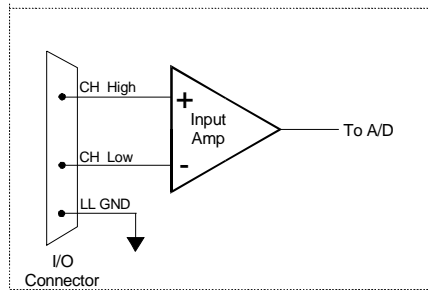

Figure 1-3. Differential Input Concept

Before describing grounding and isolation, it is important to explain the concepts of common mode voltage, and common mode range. Common mode voltage is shown in Figure 1-4 below as V_{cm} .

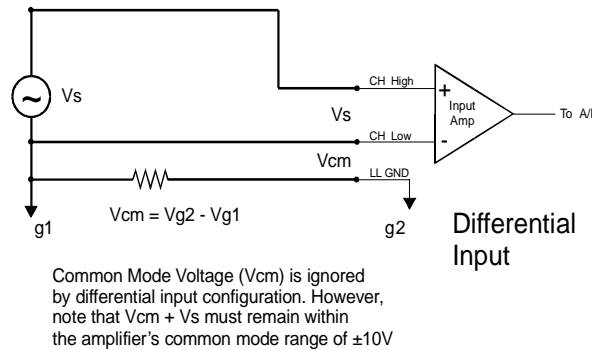

Figure 1-4. Differential Input - Voltages Defined

Although differential inputs measure the voltage between two signals—almost without respect to the either signal's voltages relative to ground—there is a voltage limit on the signal. Although the board has differential inputs, it cannot measure the difference between 100V and 101V as 1 Volt (in the first place, 100V would destroy the board!). The common mode voltage range of ± 10 Volts is shown graphically in Figure 1-5. Even in differential mode, an input signal cannot be measured if it is more than 10V from the board's LLGND

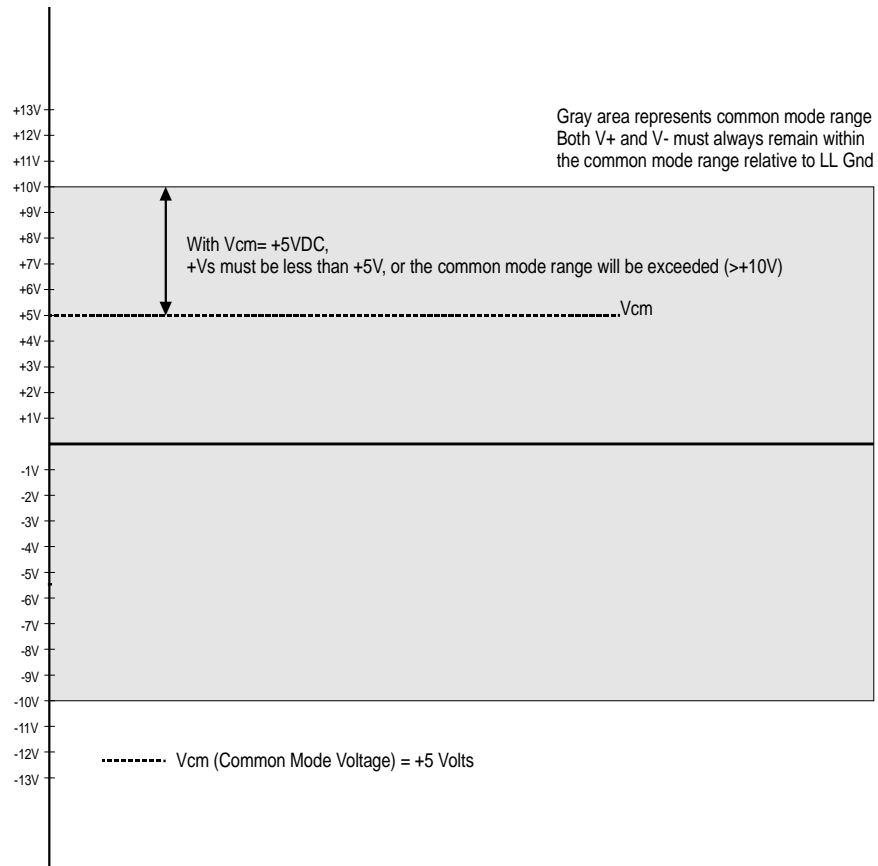

Figure 1-5. Common Mode Voltage Ranges

2 System Grounds and Isolation

There are three ways to connect a signal source to the board:

- The board's input and the signal source may have the same (or common) ground. This signal source can be connected directly to the board.
- The board input and the signal source may have an offset voltage between their grounds (AC and/or DC). This offset is the common mode voltage. Depending on the magnitude of this voltage, you may be able to connect the board directly to your signal source. We will explain this later.
- The board and the signal source may already have isolated grounds. You can connect this signal source directly to the board.

2.1 Ground Type Determination

If possible, using a battery-powered voltmeter, measure the AC and DC voltages between the signal source ground and PC ground. If you do not have access to a battery-powered voltmeter, skip this test and read sections 2.2 through 2.4. You still may be able to identify your system type from the descriptions provided.

If both AC and DC readings are 0.000 Volts, you may have a system with common grounds. However, since voltmeters will average out high frequency signals, there is no guarantee. Refer to the section 2.2, "Systems with Common Grounds."

If you measure reasonably stable AC and DC voltages, this offset is the common mode voltage. Refer to section 2.3, "Systems with Common Mode (Ground Offset) Voltages.". Please read the following warning carefully, and then proceed to sections 2.3 through 2.6 describing common mode systems.

WARNING: Do not connect board if AC or DC voltage is greater than 10 volts

If either the AC or the DC voltages are greater than 10 volts, do not connect the board to this signal source. You are beyond the board's usable common mode range and must either adjust your grounding system or add special isolation signal conditioning to take useful measurements.

A ground offset voltage of more than 30 volts will likely damage the board and possibly your computer. Note that an offset voltage greater than 30 volts will not only damage your electronics, but can be hazardous to you. In this case, either reconfigure your system to reduce the ground differentials, or install electrical isolation signal conditioning.

If you cannot obtain a reasonably stable DC voltage measurement between the grounds, or the voltage drifts around considerably, the two grounds are probably isolated. The easiest way to check for isolation is to change your voltmeter mode to resistance (use an Ohm scale) and measure the resistance between the two grounds. Turn both systems OFF prior to taking this resistance measurement. If the measured resistance is greater than 100 K Ω , your system probably has electrically-isolated grounds.

2.2 Systems with Common Grounds

In the simplest (but perhaps the least likely) case, your signal source will have the same ground potential as the board. This would typically occur when providing power or excitation to your signal source directly from the board. It is important to note that any voltage between the board's ground and your signal ground is a potential error voltage if you set up your system assuming there is a common ground.

If your signal source or sensor is not connected directly to an LFGND pin on your board, it is best to assume that you do not have a common ground even if your voltmeter measured 0.0 volts. Configure your system as if there is ground offset voltage between the source and the board. This is especially true if you are using high gains, since ground potentials in the sub milliVolt range will be large enough to cause A/D errors, but may not be measured by your handheld voltmeter.

2.3 Systems with Common Mode (Ground Offset) Voltages

The most frequently encountered grounding scenario involves grounds that are somehow connected, but have offset voltages between the board and signal source grounds. This offset voltage may be AC, DC, or both. The offset can be caused by a wide array of phenomena, such as EMI pickup, and resistive voltage drops in ground wiring and connections. Ground offset voltage is a more descriptive term for this type of system, but the term *common mode* is more frequently used (and is used in this document).

2.4 Small Common Mode Voltages

If the voltage between the signal source ground and board ground is small, the combination of the ground voltage and input signal does not exceed the allowable $\pm 10\text{V}$ common mode range. Specifically, when you add the voltage between grounds to the maximum input voltage, the result is within $\pm 10\text{V}$. This input is compatible with the board, and you can connect the system without additional signal conditioning. Fortunately, most systems fall into this category and have small voltage differentials between grounds.

2.5 Large Common Mode Voltages

If the ground differential is large enough, the allowable $\pm 10\text{V}$ does exceed the common mode range. Specifically, when you add the voltage between board and signal source grounds to the maximum input voltage you are trying to measure, the result exceeds $\pm 10\text{V}$. In this case, do not connect the board directly to the signal source. You must change your system's grounding configuration or add isolation signal conditioning. For more information, please review our ISO-RACK and ISO-5B-series products to add electrical isolation, or call our technical support group at to discuss other options.

WARNING: Avoid using earth prong of a 120VAC for signal ground connections

Do not rely on the earth prong of a 120VAC for signal ground connections. Different ground plugs may have large and potentially even dangerous voltage differentials. Remember that the ground pins on 120VAC outlets on different sides of the room may only be connected in the basement. This leaves the possibility that the "ground" pins may have a significant voltage differential—especially if the two 120VAC outlets happen to be on different line phases.

2.6 Card and Signal Source Already Have Isolated Grounds

Some signal sources will already be electrically isolated from the board. The diagram shown in Figure 3-1 shows a typical isolated ground system. These signal sources are often battery powered, or are complex equipment. Isolated ground systems provide excellent performance but require care to ensure you get optimum performance. Refer to Chapter 3, "Wiring Configurations," for more details.

3 Wiring Configurations

All grounding and input type combinations are summarized in Table 3-1. These combinations and our recommended uses are given in the table.

Table 3-1. Input Configuration Recommendations

Ground Category	Input Configuration	Our Recommendation
Common Ground	Single-Ended Inputs	Recommended
Common Ground	Differential Inputs	Acceptable
Common Mode Voltage $> \pm 0V, < \pm 10V$	Single-Ended Inputs	Not Recommended
Common Mode Voltage $< \pm 10V$	Differential Inputs	Recommended
Common Mode Voltage $> \pm 10V$	Single-Ended Inputs	Unacceptable without adding Isolation
Common Mode Voltage $> \pm 10V$	Differential Inputs	Unacceptable without adding Isolation
Already Isolated Grounds	Single-Ended Inputs	Acceptable
Already Isolated Grounds	Differential Inputs	Recommended

The following sections contain recommended input wiring schemes for each of the acceptable input configuration/grounding combinations.

3.1 Common Ground / Single-Ended Inputs

Single-ended is the recommended configuration for common ground connections. However, if some inputs are common ground and some are not, you should use the differential mode for all inputs. There is no performance penalty (other than loss of channels) for using a differential input rather than a single-ended input to measure a common ground signal source. However, the reverse is not true. Figure 3-1 below shows the recommended connections for a common ground / single-ended input system.

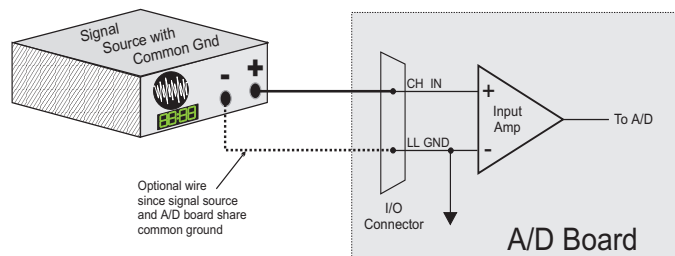

Signal source and A/D board sharing common ground connected to single-ended input.

Figure 3-1. Common Ground / Single-Ended Input System

3.2 Common Ground / Differential Inputs

Using differential inputs to monitor a signal source with a common ground is an acceptable configuration, though it requires more wiring and offers fewer channels than selecting a single-ended configuration. See Figure 3-2 for this configuration.

3.3 Common Mode Voltage < ±10V / Single-Ended Inputs

The phrase *common mode* has no meaning in a single-ended system, and this is not a recommended configuration. This case can be described as a system with offset grounds. You can try this configuration, and no system damage should occur. Depending on the overall accuracy you require, you may receive acceptable results.

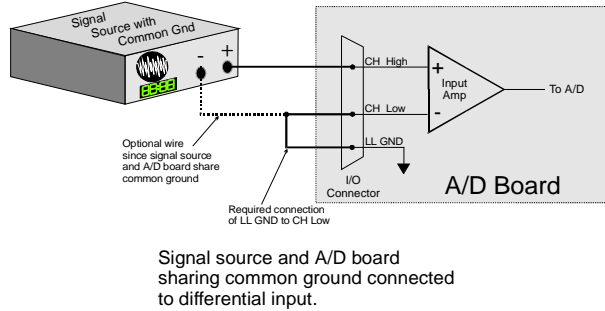

Figure 3-2. Common Ground / Differential Inputs

3.4 Common Mode Voltage < ±10V / Differential Inputs

Systems with varying ground potentials should always be monitored in the differential mode. Use care to ensure that the sum of the input signal and the ground differential (referred to as the common mode voltage) does not exceed the common mode range of the A/D board (generally ±10V). Figure 3-3 below shows recommended connections in this configuration.

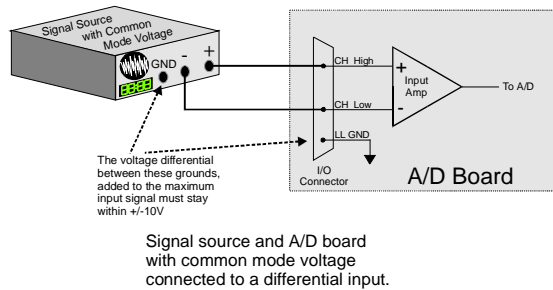
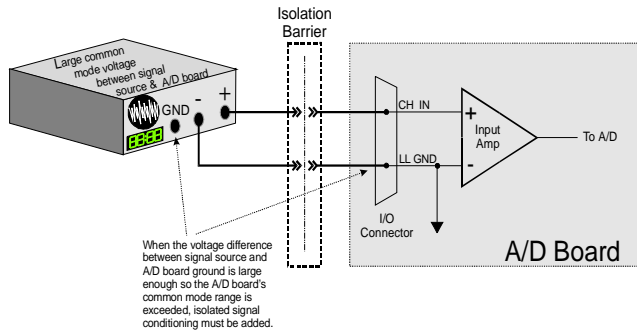

Figure 3-3. Common Mode / Differential Inputs (<±10V) Common Mode Voltage > ±10V

The board cannot directly monitor signals with common mode voltages greater than ±10V. You must alter the system ground configuration to reduce the overall common mode voltage, or add isolated signal conditioning between the source and the board (Figures 3-4 and 3-5).



System with a Large Common Mode Voltage, Connected to a Single-Ended Input

Figure 3-4. Common Mode Voltage > ±10V Single-Ended Input

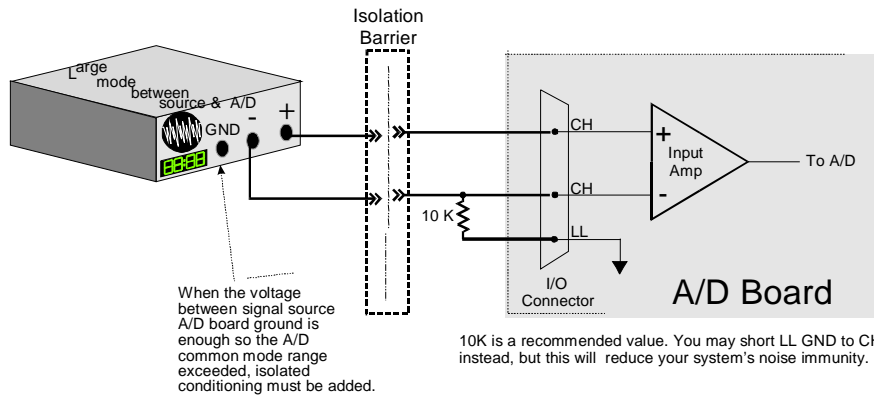

System with a Large Common Mode Voltage, Connected to a Differential Input

Figure 3-5. Common Mode Voltage > ±10V Differential Input

3.5 Isolated Grounds / Single-Ended Inputs

You can use single-ended inputs to monitor isolated inputs, although using differential mode increases your system's noise immunity. Figure 3-6 below shows the recommended connections in this configuration.

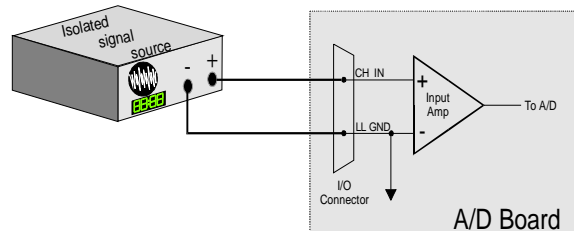

Isolated Signal Source Connected to a Single-Ended Input

Figure 3-6. Isolated Grounds / Single-Ended Inputs

3.6 Isolated Grounds / Differential Inputs

To ensure optimum performance with isolated signal sources, use the differential input setting. Figure 3-7 below shows the recommend connections for this configuration.

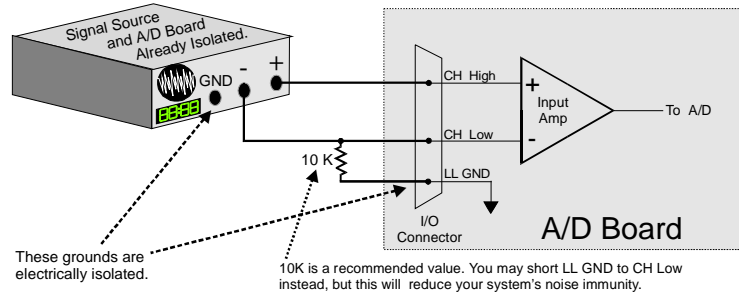

Already isolated signal source and A/D board connected to a differential input.

Figure 3-7. Isolated Grounds / Differential Inputs

4 Digital I/O Techniques

This short introduction describes a few topics often needed by board users. It covers a few key application techniques used with digital I/O.

Note: When board is powered-on or reset, digital I/O pins are set to high impedance input.

Whenever the board is powered-on or reset, all digital I/O pins are set to high impedance. If you have output devices such as solid state relays, they may be switched on whenever the computer is powered on or reset. To prevent unwanted switching, and to drive all outputs to a known, safe state after power-on or reset, pull all pins either high or low through a suitable resistor.

4.1 Pull-up & Pull-down Resistors

Whenever the board is powered on or reset, the digital I/O control registers are set to a known state. If pull-up/pull-down resistors were not used, the input bits would typically (but not certainly) float high when in the input mode. There may also be enough drive current available from the inputs to turn on connected devices.

If the inputs of the device you are controlling are left to float, they may float up or down. The way they float depends on the characteristics of the circuit and the electrical environment and may be unpredictable. The result is that your controlled device may be turned on. This is why pull-up or pull-down resistors are needed.

Using a pull-up scheme, I/O lines are connected to logic power through resistors. The high resistance values require very small drive currents. If the board is reset and enters high impedance input mode, the I/O lines are pulled high. At that point, both the board AND the attached device will sense a high signal. If the board is in output mode, it has enough power to override the pull-up resistor's high signal and drive the line to 0 volts.

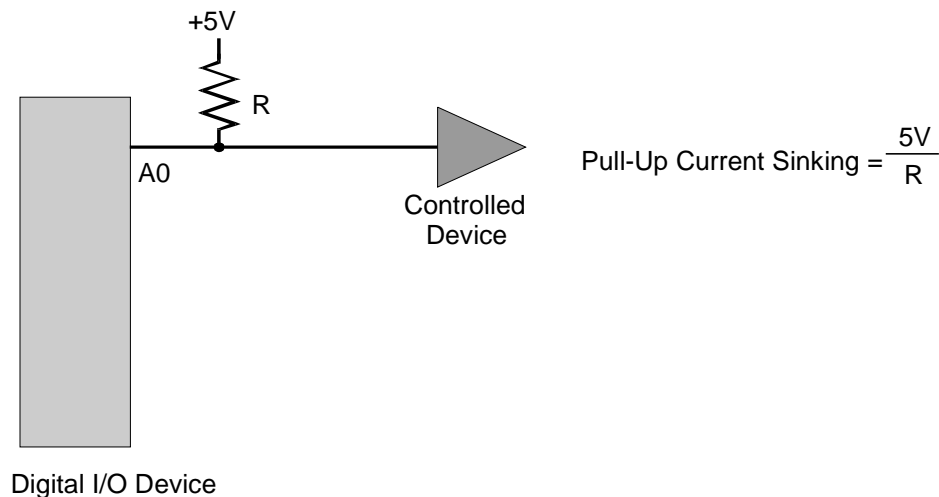

Figure 4-1. Pull-Up Resistor Configuration

Pull-down resistors accomplish similar tasks except that the I/O lines are connected to logic ground through resistors. When the board is reset, and enters high impedance input mode, the lines are pulled low. If the board is in output mode, it has enough power to override the pull-down resistor's low signal and drive the lines high.

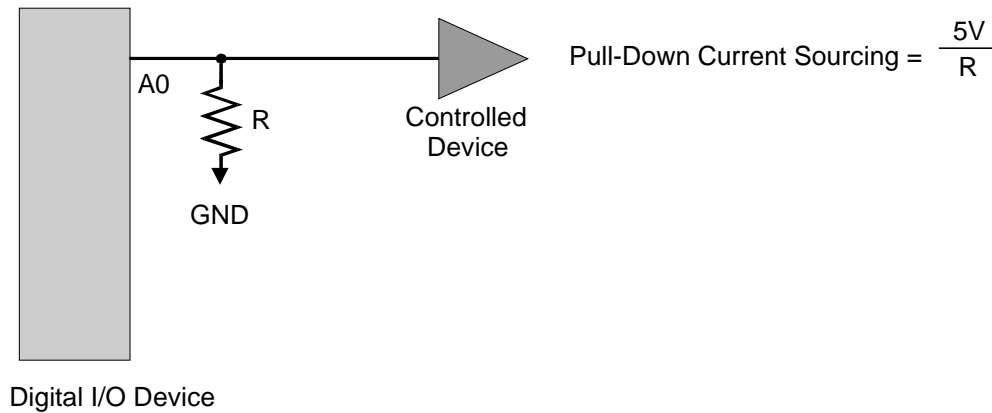

Figure 4-2. Pull-Down Resistor Configuration

4.2 TTL TO Solid State Relays

Many applications require digital outputs to switch high AC and DC voltages on and off and to monitor high AC and DC voltages. Obviously, these high voltages cannot be controlled or read directly by the TTL digital lines of a board.

Solid state relays, such as those available from Measurement Computing Corp. (MCC) allow you to control and monitor AC and high DC voltages and provide 750V isolation. Solid state relays (SSRs) are the recommended method of interfacing to AC and high DC signals.

The most convenient way to use SSRs is to purchase an SSR rack. An SSR rack is a circuit board having sockets for SSRs and buffer amplifiers powerful enough to switch the SSRs. SSR racks are available from MCC and most manufacturers of SSRs. If you have only a few outputs to control, you may also wish to consider the DR-OAC or DR-ODC, single point, DIN mountable SSRs.

4.3 Voltage Dividers

If you need to detect a signal that varies over a range greater than the maximum input specification of a digital input, you must use a voltage divider or some other external device to reduce the voltage of the input signal to a safe level.

Ohm's law states,

$$\text{Voltage} = \text{Current} \times \text{Resistance}$$

In a voltage divider, the voltage across one of the resistors in a circuit is proportional to the resistance to the total resistance in the circuit.

The object in using a voltage divider is to choose two resistors with the proper proportions relative to the full value of the input voltage to the desired output voltage to the board input.

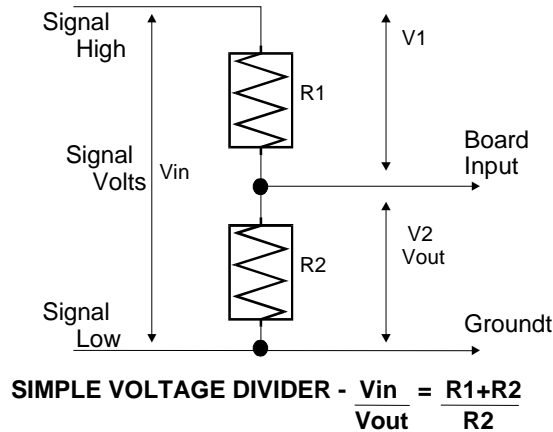

Figure 4-3. Voltage Divider Schematic

Dropping the voltage proportionally is called attenuation. The formula for attenuation is:

Table 4-1. Attenuation Formula

$\text{Attenuation} = \frac{R1+R2}{R2}$	The variable Attenuation is the proportional difference between the desired output voltage (max. input board input voltage) and the full input voltage from the field device.
$2 = \frac{10K+10K}{10K}$	For example, if the field voltage varies between 0 and 10 volts and you wish to detect that with a maximum board input voltage of 5 volts, the Attenuation must be 2:1 or simply 2.
$R1 = (A-1) \times R2$	For a given attenuation, pick a handy resistor and call it R2, then use this formula to calculate R1.

Digital inputs often require voltage dividers. For example, if you wish to detect a field signal that is at 0 volts when OFF and 24 volts when ON, you cannot connect that directly to the board's digital inputs. The voltage must be dropped to 5 volts maximum when ON. The Attenuation required is 24:5 or 4.8. Use the equation above to find an appropriate R1 if R2 is 1K. Remember that a TTL input is 'ON' when the input voltage is greater than 2.5 volts.

Note: Equation for dissipation of power in the divider

The resistors, R1 and R2, are going to dissipate all the power in the divider circuit according to the equation:

$$\text{Current} = \text{Voltage} / \text{Resistance}.$$

The higher the value of the resistance (R1 + R2), the less power dissipated by the divider circuit.

As a simple rule:

For attenuation of 5:1 or less, no resistor should be less than 10K.

For attenuation of greater than 5:1, no resistor should be less than 1K.

4.4 Low Pass Filter to De-bounce Inputs

A low pass filter is placed on the signal wires between a source and the board. It prevents frequencies greater than the cut-off frequency from entering the board's digital inputs.

The cut-off frequency is the frequency above which no variation of voltage, with respect to time, may enter the circuit. For example, if a low-pass filter had a cut-off frequency of 30 Hz, the interference associated with line voltage (60 Hz) would be mostly filtered out but a signal of 25 Hz would pass with less attenuation.

In a digital circuit, a low pass filter might be used to “de-bounce” (filter) an input from a switch or external relay. (Unless switch/relay contacts are mercury-whetted, they tend to bounce briefly on closure, generating a pulsating noise signal.) A simple low-pass filter can be constructed from one resistor (R) and one capacitor (C) (refer to Figure 4-4).

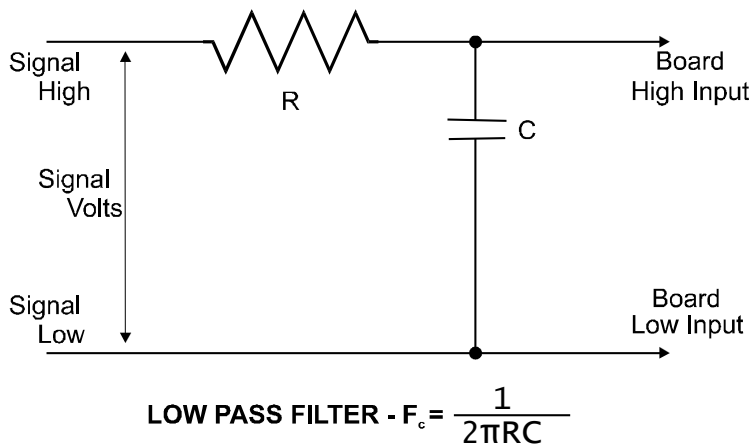

Figure 4-4. Low-Pass Filter Schematic

The cut-off frequency is determined according to the formula:

$$F_c = \frac{1}{2 \pi R C}$$

$$R = \frac{1}{2 \pi C F_c}$$

Where $\pi = 3.14...$

R = ohms

C = farads

Fc = cut-off frequency in cycles/second

Measurement Computing Corporation
16 Commerce Boulevard
Middleboro, Massachusetts 02346
(508) 946-5100
Fax: (508) 946-9500
E-mail: info@measurementcomputing.com
www.measurementcomputing.com