

D  
C  
B  
A

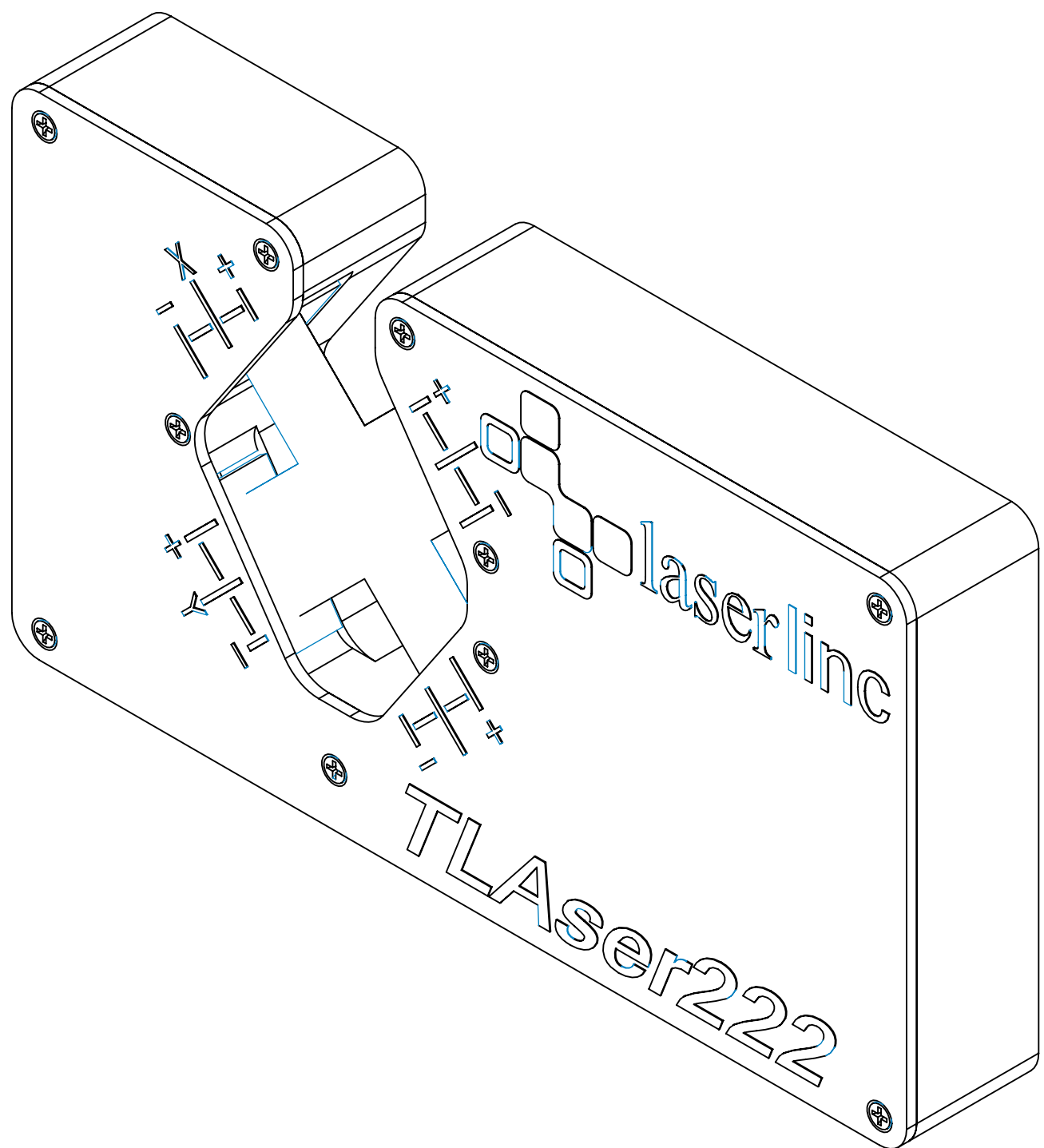

# 222 Gauge mounting dimensions

Dimensions are in inches

**PROPRIETARY AND CONFIDENTIAL**  
 THE INFORMATION CONTAINED IN THIS DRAWING IS THE SOLE PROPERTY OF LASERLINC, INC. ANY REPRODUCTION IN PART OR AS A WHOLE WITHOUT THE WRITTEN PERMISSION OF LASERLINC, INC IS PROHIBITED.

		UNLESS OTHERWISE SPECIFIED:		NAME	DATE	LaserLinc, Inc.	
		DIMENSIONS ARE IN INCHES		DRAWN	JWL	05/12/08	
		TOLERANCES:		CHECKED			TITLE:
		FRACTIONAL ±		ENG APPR.			LaserLinc TLaser222 Mounting Dimensions
		ANGULAR: MACH ± BEND ±		MFG APPR.			
		TWO PLACE DECIMAL ±0.010		Q.A.			
		THREE PLACE DECIMAL ±0.005		COMMENTS:	63 RA surface finish		
		INTERPRET GEOMETRIC TOLERANCING PER:					SIZE DWG. NO. REV
		MATERIAL					<b>B</b> <b>0</b>
NEXT ASSY	USED ON	FINISH					SCALE: 1:1 WEIGHT: SHEET 1 OF 2
APPLICATION		DO NOT SCALE DRAWING					

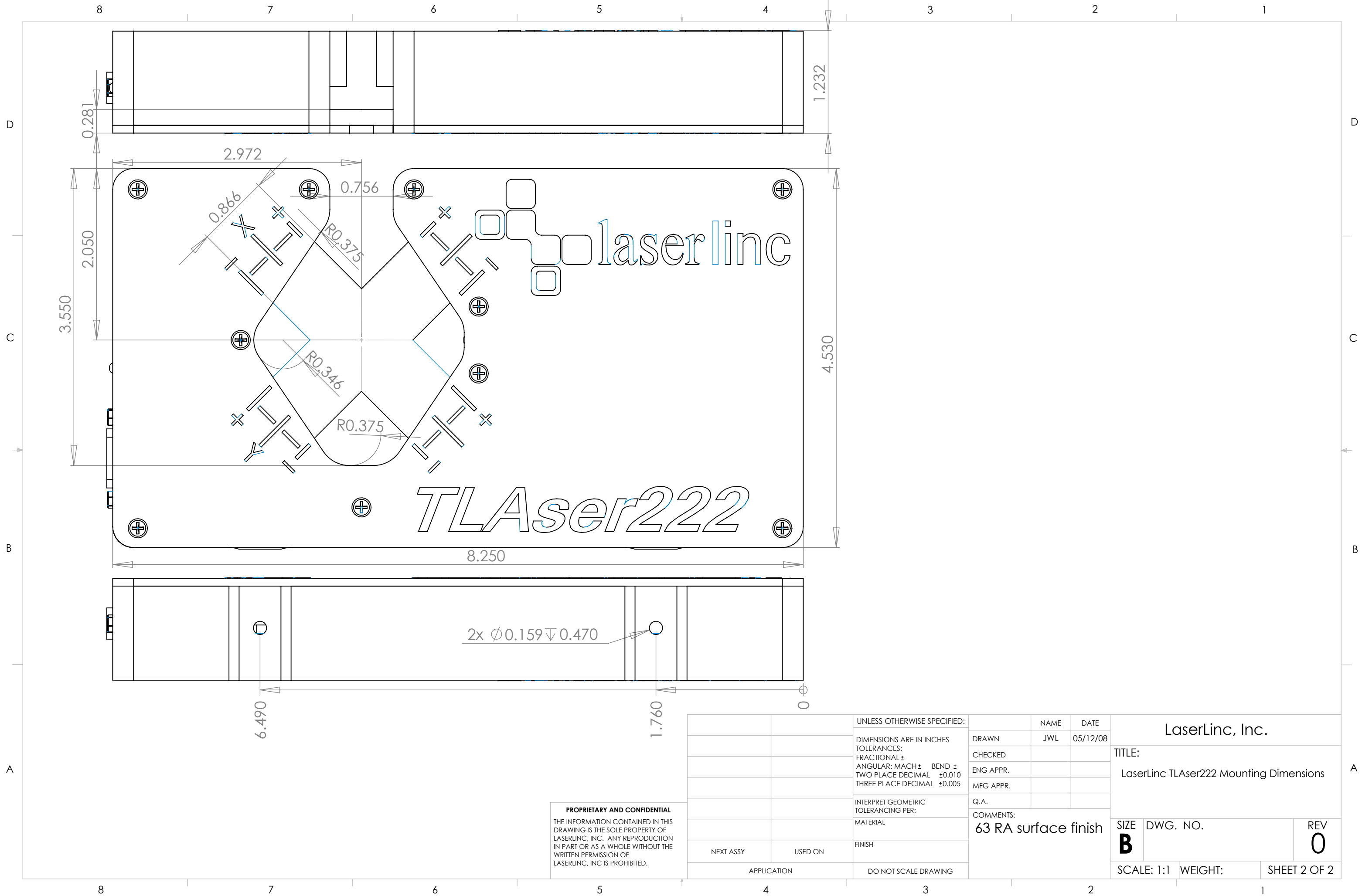

**PROPRIETARY AND CONFIDENTIAL**  
 THE INFORMATION CONTAINED IN THIS DRAWING IS THE SOLE PROPERTY OF LASERLINC, INC. ANY REPRODUCTION IN PART OR AS A WHOLE WITHOUT THE WRITTEN PERMISSION OF LASERLINC, INC IS PROHIBITED.

		UNLESS OTHERWISE SPECIFIED:				LaserLinc, Inc.	
		DIMENSIONS ARE IN INCHES		DRAWN	NAME	DATE	TITLE: LaserLinc TLAser222 Mounting Dimensions
		TOLERANCES:		CHECKED	JWL	05/12/08	
		FRACTIONAL ±		ENG APPR.			
		ANGULAR: MACH ± BEND ±		MFG APPR.			
		TWO PLACE DECIMAL ±0.010		Q.A.			SIZE DWG. NO. REV <b>B</b> <b>0</b>
		THREE PLACE DECIMAL ±0.005		COMMENTS:	63 RA surface finish		
		INTERPRET GEOMETRIC TOLERANCING PER:					
		MATERIAL					
		FINISH					
NEXT ASSY	USED ON	APPLICATION		DO NOT SCALE DRAWING		SCALE: 1:1 WEIGHT: SHEET 2 OF 2	