

8 7 6 5 4 3 2 1

F

E

D

C

B

A

F

E

D

C

B

A

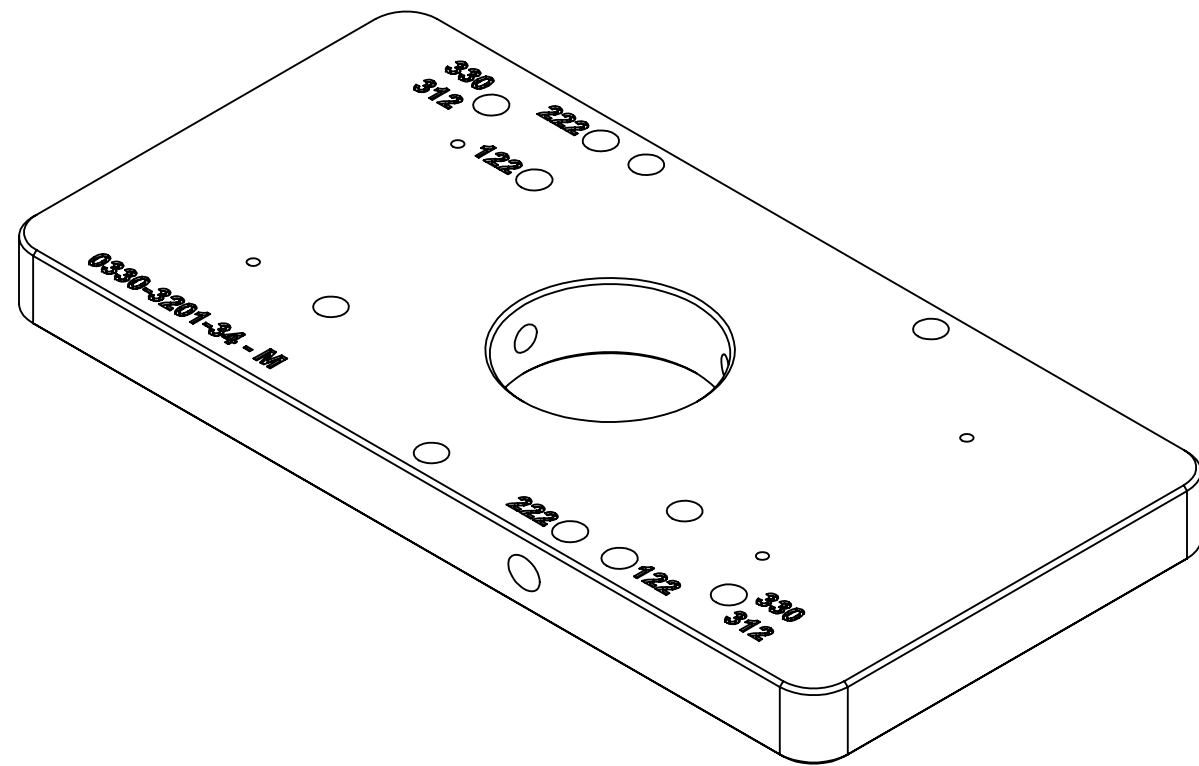

330 CAL FIXTURE PLATE

INDEX

- (1) COVER PAGE
- (2) DIMENSIONS

GENERAL FINISH NOTE		UNLESS OTHERWISE SPECIFIED:		NAME	DATE	 LaserLinc, Inc. Phone: 888-707-4892 Info@laserlinc.com www.laserlinc.com
DE-BURR AND BREAK ALL SHARP EDGES BEFORE FINISH AND/OR SHIPPING		DIMENSIONS ARE IN INCHES TOLERANCES: ANGULAR: MACH ± BEND ± TWO PLACE DECIMAL ±0.010 THREE PLACE DECIMAL ±0.005 FOUR PLACE DECIMAL ±0.0005 ANGLES ±.25° UNMARKED FILLETS/ROUNDS R.0625 DE-BURR ALL PARTS		DRAWN BY:	EMM	
PROPRIETARY AND CONFIDENTIAL		INTERPRET GEOMETRIC TOLERANCING PER:				
THE INFORMATION CONTAINED IN THIS DRAWING IS THE SOLE PROPERTY OF LASERLINC, INC. ANY REPRODUCTION IN PART OR AS A WHOLE WITHOUT THE WRITTEN PERMISSION OF LASERLINC, INC. IS PROHIBITED.		MATERIAL Black Delrin		63 RA SURFACE FINISH ALL FEATURES MUST MEET SPECIFICATION AFTER PLATING BEFORE POWDER-COAT IF PLATED OR POWDER-COATED SEE FINISH MACHINE ALL SURFACES		TITLE: 0330-3201-34 330 Cal Fixture Plate Overalls
		FINISH		SIZE B		DWG. NO. 0330-3201-34
		DO NOT SCALE DRAWING		REV A		SCALE: 1:1
				SHEET 1 OF 2		

8 7 6 5 4 3 2 1

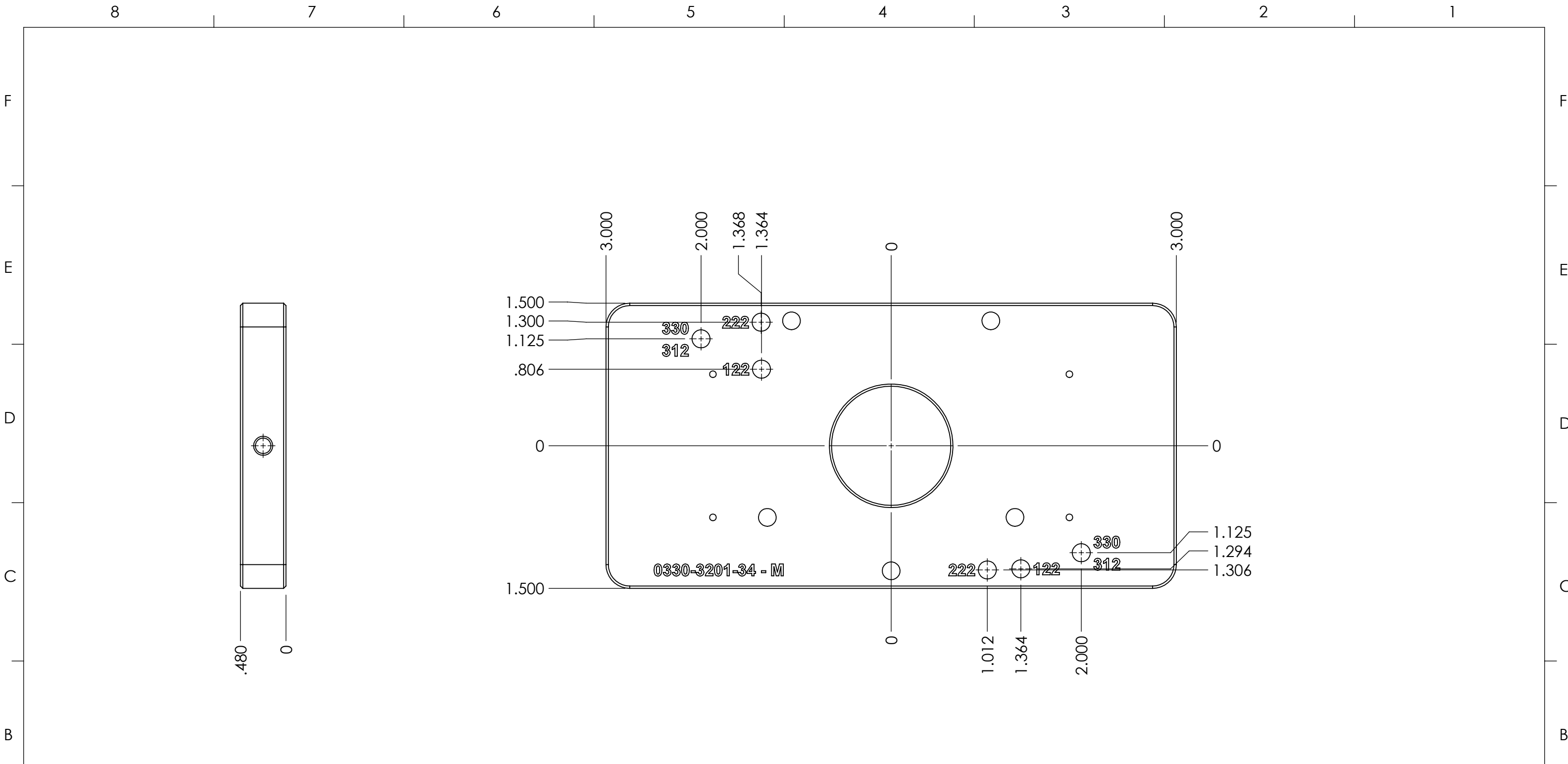

<p>GENERAL FINISH NOTE</p> <p>DE-BURR AND BREAK ALL SHARP EDGES BEFORE FINISH AND/OR SHIPPING</p> <p>PROPRIETARY AND CONFIDENTIAL</p> <p>THE INFORMATION CONTAINED IN THIS DRAWING IS THE SOLE PROPERTY OF LASERLINC, INC. ANY REPRODUCTION IN PART OR AS A WHOLE WITHOUT THE WRITTEN PERMISSION OF LASERLINC, INC IS PROHIBITED.</p>	<p>UNLESS OTHERWISE SPECIFIED:</p> <p>DIMENSIONS ARE IN INCHES</p> <p>TOLERANCES:</p> <p>ANGULAR: MACH ± BEND ±</p> <p>TWO PLACE DECIMAL ±0.010</p> <p>THREE PLACE DECIMAL ±0.005</p> <p>FOUR PLACE DECIMAL ±0.0005</p> <p>ANGLES ±.25°</p> <p>UNMARKED FILLETS/ROUNDS R.0625</p> <p>DE-BURR ALL PARTS</p>	<p>NAME</p> <p>DATE</p>	<p> LaserLinc, Inc.</p> <p>Phone: 888-707-4892 Info@laserlinc.com www.laserlinc.com</p>	
	<p>INTERPRET GEOMETRIC TOLERANCING PER:</p>	<p>DRAWN BY:</p> <p>EMM</p> <p>9/25/2020</p>		<p>TITLE:</p> <p>0330-3201-34 330 Cal Fixture Plate Overalls</p>
	<p>MATERIAL Black Delrin</p> <p>FINISH</p> <p>DO NOT SCALE DRAWING</p>	<p>63 RA SURFACE FINISH ALL FEATURES MUST MEET SPECIFICATION AFTER PLATING BEFORE POWDER-COAT IF PLATED OR POWDER-COATED SEE FINISH MACHINE ALL SURFACES</p>		<p>SIZE</p> <p>B</p> <p>DWG. NO.</p> <p>0330-3201-34</p> <p>REV</p> <p>A</p>
	<p>SCALE: 1:1</p> <p>SHEET 2 OF 2</p>	<p>SCALE: 1:1</p> <p>SHEET 2 OF 2</p>		<p>SCALE: 1:1</p> <p>SHEET 2 OF 2</p>