

8

7

6

5

4

3

2

1

| REVISIONS | | | | |
|-----------|------|-------------|-----------|----------|
| ZONE | REV. | DESCRIPTION | DATE | APPROVED |
| | A | Check-In | 5/27/2015 | MAM |

F

F

E

E

D

D

C

C

B

B

A

A

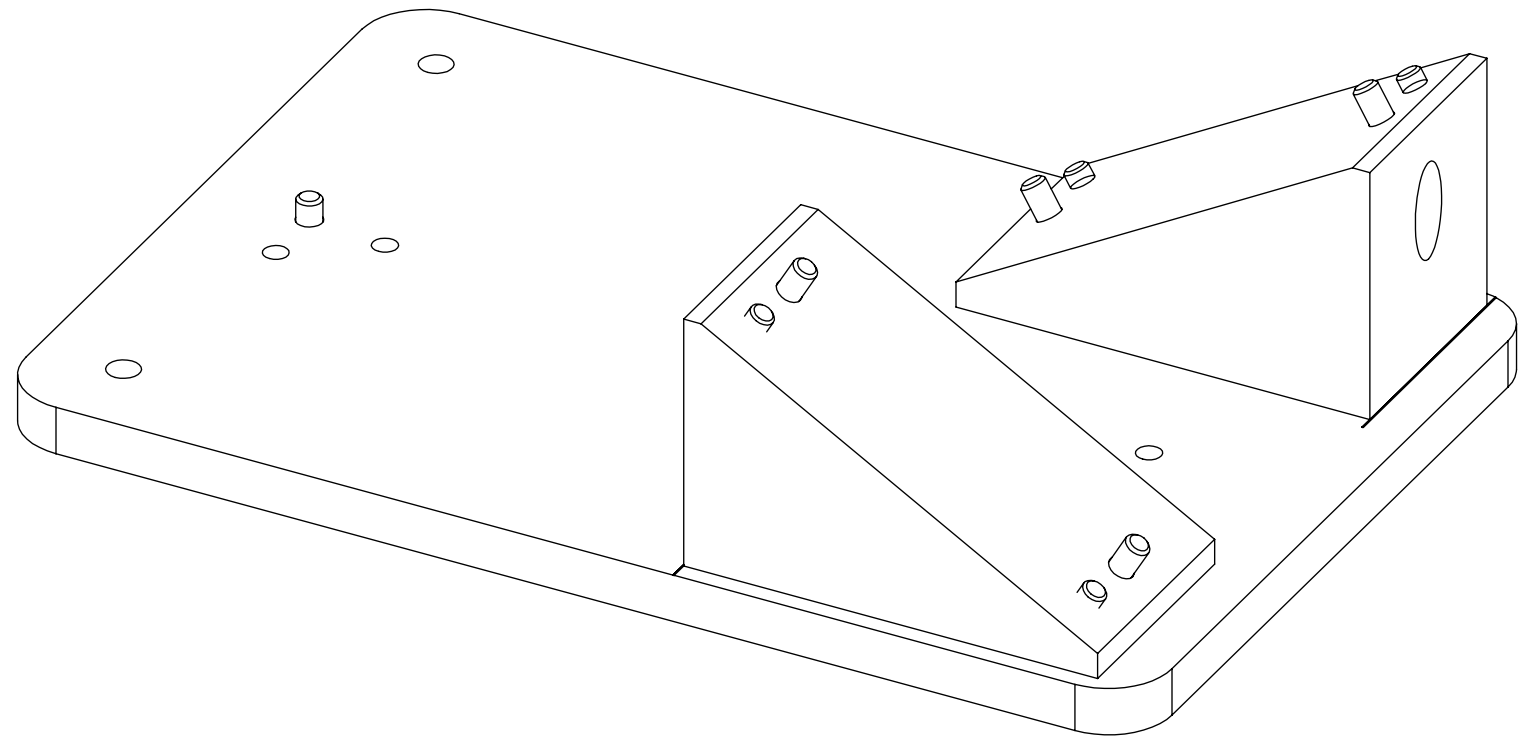

AXION103 TRIPLE MOUNT FIXTURE OVERALLS

INDEX

- (1) COVER PAGE
- (2) DIMENSIONS

| | | | | | | |
|--|--|--|--|--|------|--|
| GENERAL FINISH NOTE | | UNLESS OTHERWISE SPECIFIED: | | NAME | DATE |  LASERLINC, INC. PHONE: 888-707-4892 INFO@LASERLINC.COM WWW.LASERLINC.COM |
| DE-BURR AND BREAK ALL SHARP EDGES BEFORE FINISH AND/OR SHIPPING | | DIMENSIONS ARE IN INCHES TOLERANCES: ANGLES ±.25° TWO PLACE DECIMAL ±0.010 THREE PLACE DECIMAL ±0.005 FOUR PLACE DECIMAL ±0.0005 UNMARKED FILLETS/CHAMFER .06 DE-BURR ALL PARTS | | DRAWN BY: | EMM | |
| PROPRIETARY AND CONFIDENTIAL THE INFORMATION CONTAINED IN THIS DRAWING IS THE SOLE PROPERTY OF LASERLINC, INC. ANY REPRODUCTION IN PART OR AS A WHOLE WITHOUT THE WRITTEN PERMISSION OF LASERLINC, INC. IS PROHIBITED. | | INTERPRET GEOMETRIC TOLERANCING PER: ASME Y14.5 | | 63 RA SURFACE FINISH ALL FEATURES MUST MEET SPECIFICATION AFTER PLATING BEFORE POWDER-COAT IF PLATED OR POWDER-COATED SEE FINISH | | TITLE: 0103-0000-29 AXION103 TRIPLE MOUNT FIXTURE OVERALLS |
| | | MATERIAL | | SIZE B DWG. NO. 0103-0000-29 SCALE: 3:4 | | REV A SHEET 1 OF 2 |
| | | FINISH | | | | |
| | | DO NOT SCALE DRAWING | | | | |

8

7

6

5

4

3

2

1

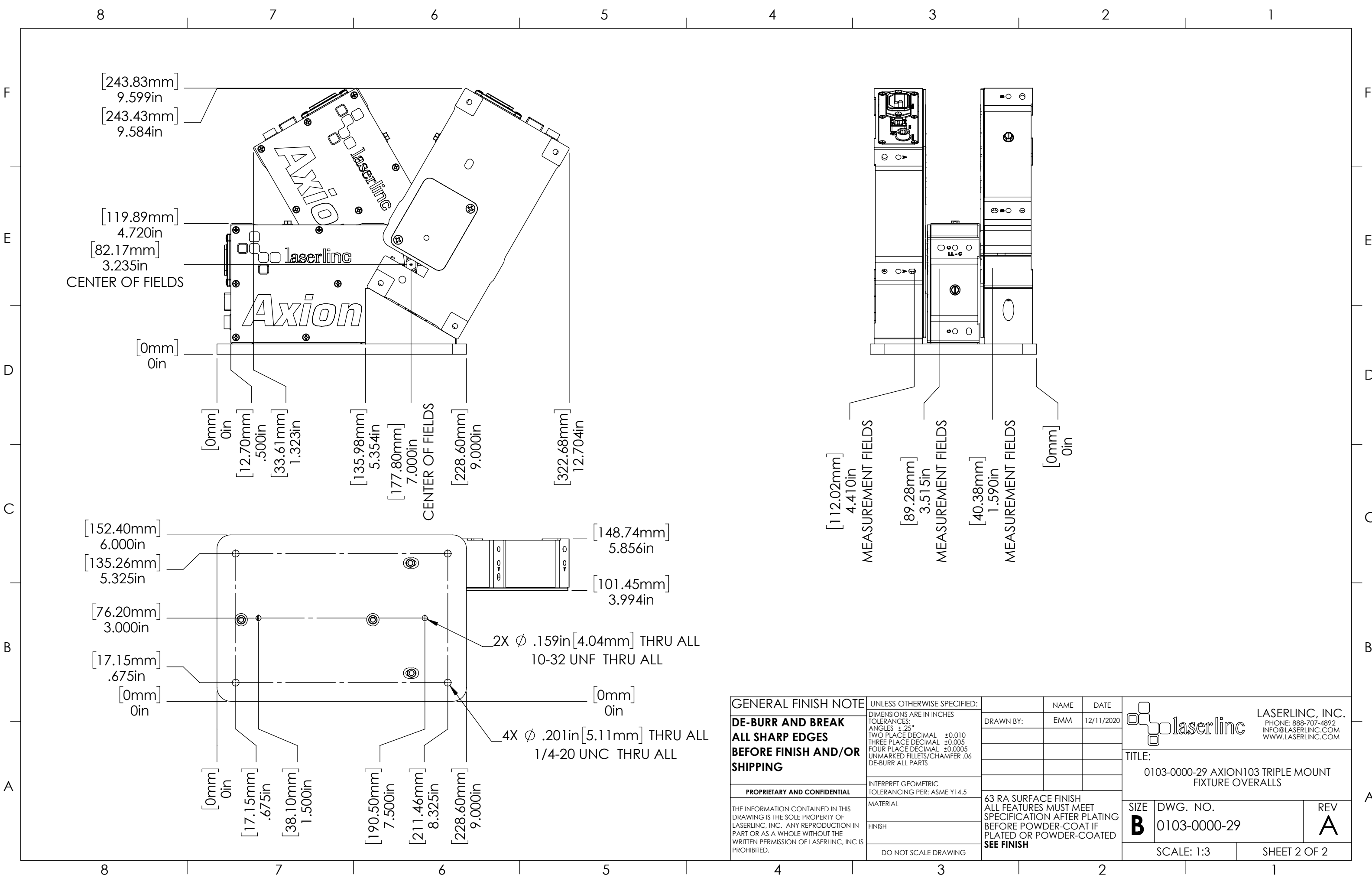

| | | | |
|---|---|--|---------------------------------|
| GENERAL FINISH NOTE | UNLESS OTHERWISE SPECIFIED: | NAME | DATE |
| | DE-BURR AND BREAK ALL SHARP EDGES BEFORE FINISH AND/OR SHIPPING | DRAWN BY: EMM | 12/11/2020 |
| PROPRIETARY AND CONFIDENTIAL | DIMENSIONS ARE IN INCHES TOLERANCES: ANGLES \pm .25 TWO PLACE DECIMAL \pm 0.010 THREE PLACE DECIMAL \pm 0.005 FOUR PLACE DECIMAL \pm 0.0005 UNMARKED FILLETS/CHAMFER .06 DE-BURR ALL PARTS |  LASERLINC, INC. PHONE: 888-707-4892 INFO@LASERLINC.COM WWW.LASERLINC.COM | |
| THE INFORMATION CONTAINED IN THIS DRAWING IS THE SOLE PROPERTY OF LASERLINC, INC. ANY REPRODUCTION IN PART OR AS A WHOLE WITHOUT THE WRITTEN PERMISSION OF LASERLINC, INC. IS PROHIBITED. | INTERPRET GEOMETRIC TOLERANCING PER: ASME Y14.5 | TITLE: 0103-0000-29 AXION103 TRIPLE MOUNT FIXTURE OVERALLS | |
| | MATERIAL | 63 RA SURFACE FINISH ALL FEATURES MUST MEET SPECIFICATION AFTER PLATING BEFORE POWDER-COAT IF PLATED OR POWDER-COATED SEE FINISH | |
| | FINISH | SIZE B | DWG. NO. 0103-0000-29 |
| | DO NOT SCALE DRAWING | REV A | SCALE: 1:3 SHEET 2 OF 2 |