

8

7

6

5

4

3

2

1

REVISIONS				
ZONE	REV.	DESCRIPTION	DATE	APPROVED
	A	Check-In	7/1/2014	MAM

F

F

E

E

D

D

C

C

B

B

A

A

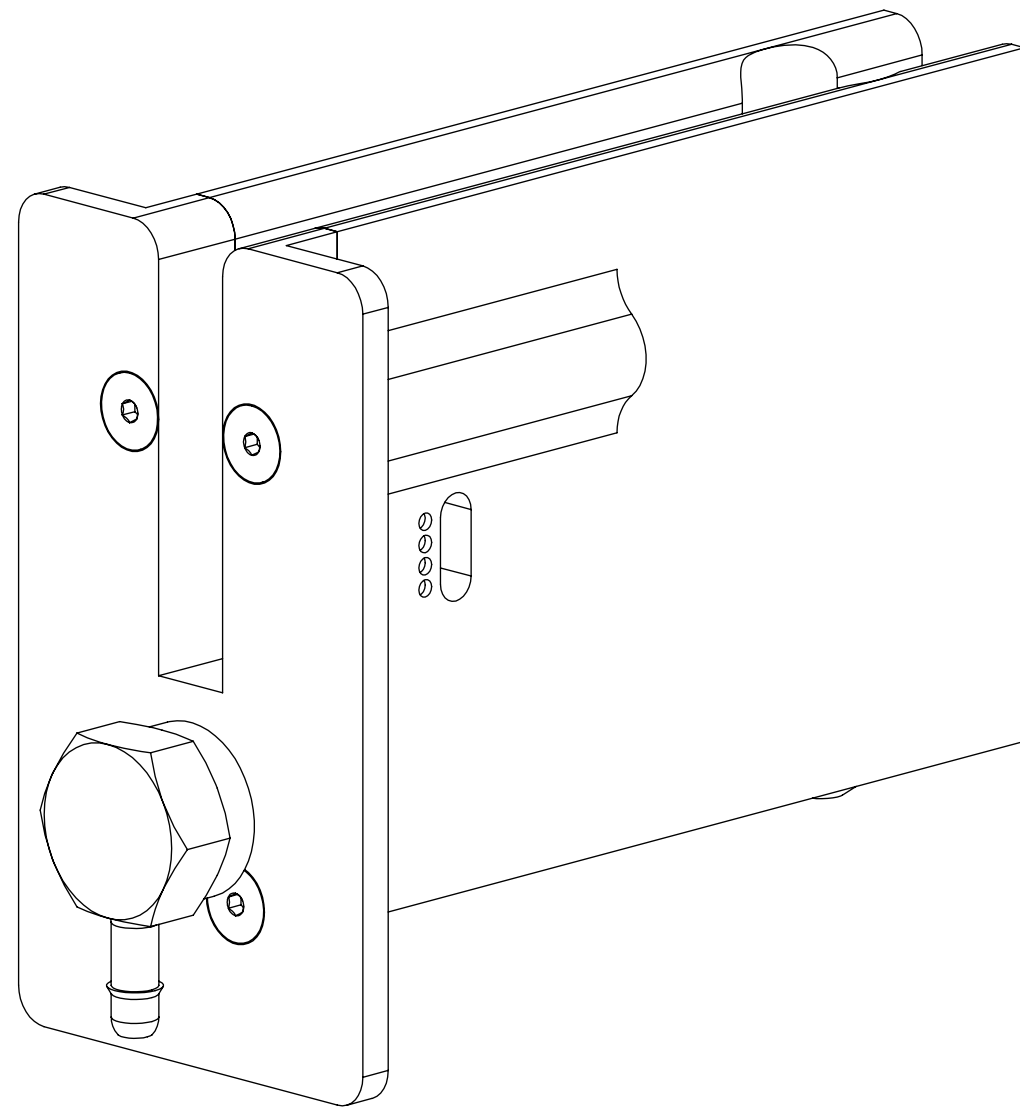

# AXION103 AIR PURGE FIXTURE OVERALLS

## INDEX

- (1) COVER PAGE
- (2) FIXTURE DIMENSIONS
- (3) MOUNTED DIMENSIONS

<b>GENERAL FINISH NOTE</b>		UNLESS OTHERWISE SPECIFIED:		NAME	DATE	 <b>LaserLinc, Inc.</b> Phone: 888-707-4892 Info@laserlinc.com www.laserlinc.com
<b>DE-BURR AND BREAK ALL SHARP EDGES BEFORE FINISH AND/OR SHIPPING</b>		DIMENSIONS ARE IN INCHES TOLERANCES: ANGLES ±.25 TWO PLACE DECIMAL ±0.010 THREE PLACE DECIMAL ±0.005 FOUR PLACE DECIMAL ±0.0005 UNMARKED FILLETS/CHAMFER .06 DE-BURR ALL PARTS		DRAWN BY:	EMM	
PROPRIETARY AND CONFIDENTIAL  THE INFORMATION CONTAINED IN THIS DRAWING IS THE SOLE PROPERTY OF LASERLINC, INC. ANY REPRODUCTION IN PART OR AS A WHOLE WITHOUT THE WRITTEN PERMISSION OF LASERLINC, INC. IS PROHIBITED.		INTERPRET GEOMETRIC TOLERANCING PER: ASME Y14.5  MATERIAL  FINISH  DO NOT SCALE DRAWING		63 RA SURFACE FINISH ALL FEATURES MUST MEET SPECIFICATION AFTER PLATING BEFORE POWDER-COAT IF PLATED OR POWDER-COATED SEE FINISH		<b>TITLE:</b> 0103-0000-30 AXION103 AIR PURGE FIXTURE OVERALLS
		SIZE	DWG. NO.	REV		
		<b>B</b>	0103-0000-30	<b>A</b>		
		SCALE: 3:1		SHEET 1 OF 3		

8

7

6

5

4

3

2

1

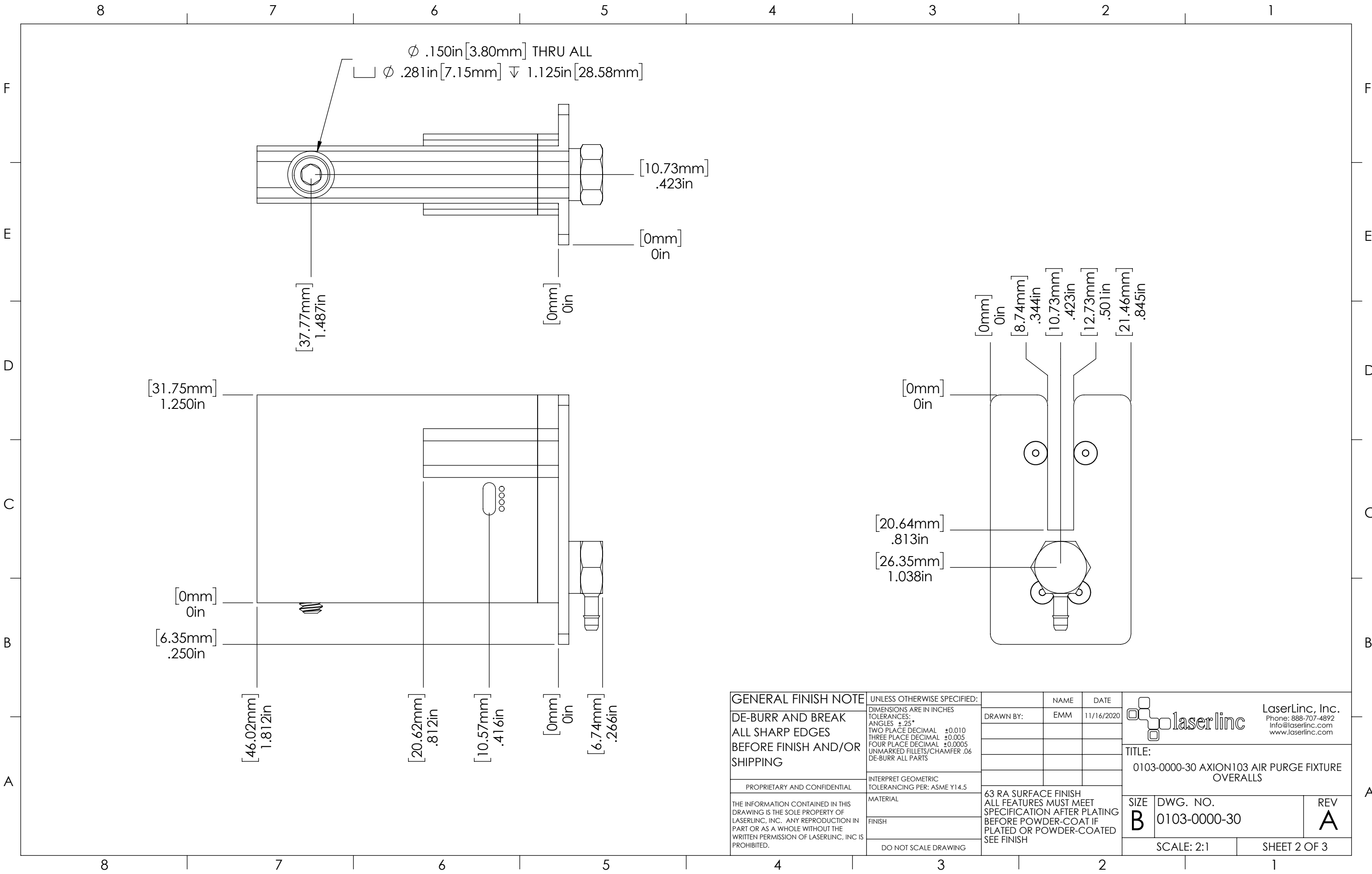

Ø .150in [3.80mm] THRU ALL  
 Ø .281in [7.15mm] ∇ 1.125in [28.58mm]

[31.75mm]  
1.250in

[0mm]  
0in

[6.35mm]  
.250in

[46.02mm]  
1.812in

[20.62mm]  
.812in

[10.57mm]  
.416in

[0mm]  
0in

[6.74mm]  
.266in

[10.73mm]  
.423in

[0mm]  
0in

[37.77mm]  
1.487in

[0mm]  
0in

[0mm]  
0in

[20.64mm]  
.813in

[26.35mm]  
1.038in

[0mm]  
0in

[8.74mm]  
.344in

[10.73mm]  
.423in

[12.73mm]  
.501in

[21.46mm]  
.845in

<b>GENERAL FINISH NOTE</b>		UNLESS OTHERWISE SPECIFIED:		NAME	DATE
DE-BURR AND BREAK ALL SHARP EDGES BEFORE FINISH AND/OR SHIPPING		DIMENSIONS ARE IN INCHES TOLERANCES: ANGLES ±.25 TWO PLACE DECIMAL ±0.010 THREE PLACE DECIMAL ±0.005 FOUR PLACE DECIMAL ±0.0005 UNMARKED FILLETS/CHAMFER .06 DE-BURR ALL PARTS		DRAWN BY:	EMM 11/16/2020
PROPRIETARY AND CONFIDENTIAL		INTERPRET GEOMETRIC TOLERANCING PER: ASME Y14.5			
THE INFORMATION CONTAINED IN THIS DRAWING IS THE SOLE PROPERTY OF LASERLINC, INC. ANY REPRODUCTION IN PART OR AS A WHOLE WITHOUT THE WRITTEN PERMISSION OF LASERLINC, INC IS PROHIBITED.		MATERIAL		63 RA SURFACE FINISH ALL FEATURES MUST MEET SPECIFICATION AFTER PLATING BEFORE POWDER-COAT IF PLATED OR POWDER-COATED SEE FINISH	
		FINISH			
		DO NOT SCALE DRAWING			
 LaserLinc, Inc. Phone: 888-707-4892 Info@laserlinc.com www.laserlinc.com				TITLE:	
				0103-0000-30 AXION103 AIR PURGE FIXTURE OVERALLS	
SIZE	DWG. NO.	REV			
<b>B</b>	0103-0000-30	<b>A</b>			
SCALE: 2:1			SHEET 2 OF 3		

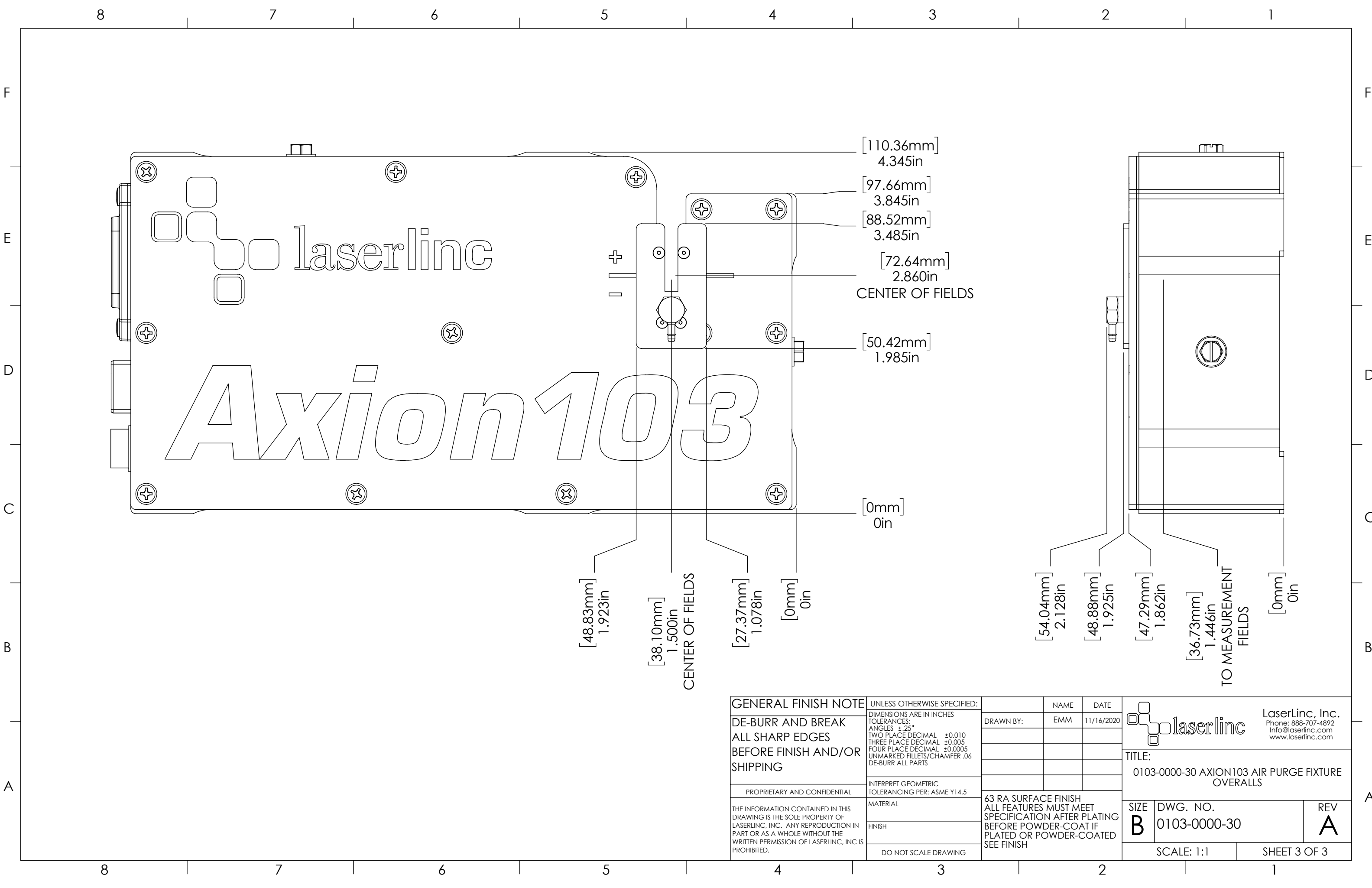

[110.36mm]  
4.345in

[97.66mm]  
3.845in

[88.52mm]  
3.485in

[72.64mm]  
2.860in  
CENTER OF FIELDS

[50.42mm]  
1.985in

[0mm]  
0in

[48.83mm]  
1.923in

[38.10mm]  
1.500in  
CENTER OF FIELDS

[27.37mm]  
1.078in

[0mm]  
0in

[54.04mm]  
2.128in

[48.88mm]  
1.925in

[47.29mm]  
1.862in

[36.73mm]  
1.446in  
TO MEASUREMENT  
FIELDS

[0mm]  
0in

<b>GENERAL FINISH NOTE</b>		UNLESS OTHERWISE SPECIFIED:		NAME	DATE
DE-BURR AND BREAK ALL SHARP EDGES BEFORE FINISH AND/OR SHIPPING		DIMENSIONS ARE IN INCHES TOLERANCES: ANGLES ±.25 TWO PLACE DECIMAL ±0.010 THREE PLACE DECIMAL ±0.005 FOUR PLACE DECIMAL ±0.0005 UNMARKED FILLETS/CHAMFER .06 DE-BURR ALL PARTS		DRAWN BY:	EMM 11/16/2020
PROPRIETARY AND CONFIDENTIAL		INTERPRET GEOMETRIC TOLERANCING PER: ASME Y14.5			
THE INFORMATION CONTAINED IN THIS DRAWING IS THE SOLE PROPERTY OF LASERLINC, INC. ANY REPRODUCTION IN PART OR AS A WHOLE WITHOUT THE WRITTEN PERMISSION OF LASERLINC, INC. IS PROHIBITED.		MATERIAL		63 RA SURFACE FINISH ALL FEATURES MUST MEET SPECIFICATION AFTER PLATING BEFORE POWDER-COAT IF PLATED OR POWDER-COATED SEE FINISH	
		FINISH		TITLE: 0103-0000-30 AXION103 AIR PURGE FIXTURE OVERALLS	
		DO NOT SCALE DRAWING		SIZE <b>B</b>	DWG. NO. 0103-0000-30
				REV <b>A</b>	
				SCALE: 1:1	SHEET 3 OF 3

