

8

7

6

5

4

3

2

1

REVISIONS				
ZONE	REV.	DESCRIPTION	DATE	APPROVED
	A	Check-In	9/4/2013	MAM

F

F

E

E

D

D

C

C

B

B

A

A

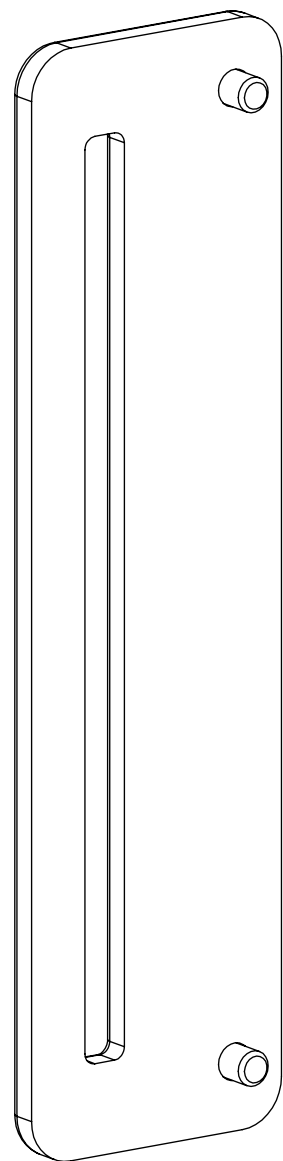
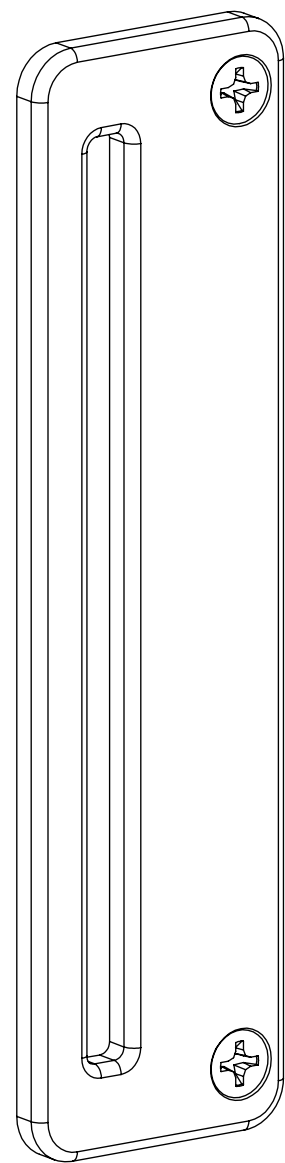

AXION 1120 WINDOW GUARD OVERALLS

INDEX

- (1) COVER PAGE
- (2) DIMENSIONS

GENERAL FINISH NOTE	UNLESS OTHERWISE SPECIFIED:	NAME	DATE	 LaserLinc, Inc. Phone: 888-707-4892 Info@laserlinc.com www.laserlinc.com
	DIMENSIONS ARE IN INCHES TOLERANCES: ANGLES ±.25 TWO PLACE DECIMAL ±0.010 THREE PLACE DECIMAL ±0.005 FOUR PLACE DECIMAL ±0.0005 UNMARKED FILLETS/CHAMFER .06 DE-BURR ALL PARTS	DRAWN BY:	EMM	
DE-BURR AND BREAK ALL SHARP EDGES BEFORE FINISH AND/OR SHIPPING	INTERPRET GEOMETRIC TOLERANCING PER: ASME Y14.5			TITLE: 1120-0000-31 AXION1120 WINDOW GUARD OVERALLS
PROPRIETARY AND CONFIDENTIAL	MATERIAL			SIZE DWG. NO. REV B 1120-0000-31 A
THE INFORMATION CONTAINED IN THIS DRAWING IS THE SOLE PROPERTY OF LASERLINC, INC. ANY REPRODUCTION IN PART OR AS A WHOLE WITHOUT THE WRITTEN PERMISSION OF LASERLINC, INC. IS PROHIBITED.	FINISH	63 RA SURFACE FINISH ALL FEATURES MUST MEET SPECIFICATION AFTER PLATING BEFORE POWDER-COAT IF PLATED OR POWDER-COATED SEE FINISH		SCALE: 1:1 SHEET 1 OF 2
	DO NOT SCALE DRAWING			

8

7

6

5

4

3

2

1

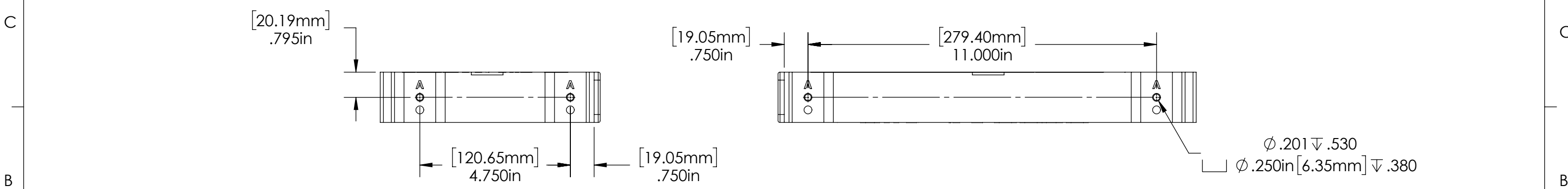
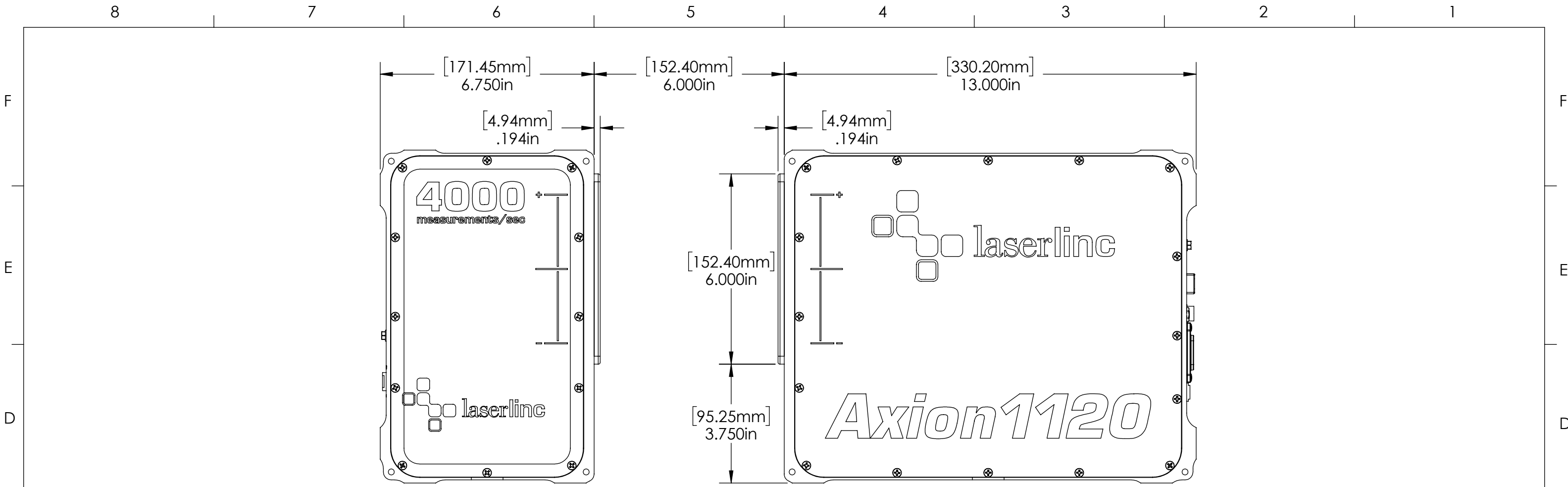

GENERAL FINISH NOTE DE-BURR AND BREAK ALL SHARP EDGES BEFORE FINISH AND/OR SHIPPING PROPRIETARY AND CONFIDENTIAL THE INFORMATION CONTAINED IN THIS DRAWING IS THE SOLE PROPERTY OF LASERLINC, INC. ANY REPRODUCTION IN PART OR AS A WHOLE WITHOUT THE WRITTEN PERMISSION OF LASERLINC, INC. IS PROHIBITED.	UNLESS OTHERWISE SPECIFIED: DIMENSIONS ARE IN INCHES TOLERANCES: ANGLES ±.25 TWO PLACE DECIMAL ±0.010 THREE PLACE DECIMAL ±0.005 FOUR PLACE DECIMAL ±0.0005 UNMARKED FILLETS/CHAMFER .06 DE-BURR ALL PARTS	NAME DATE DRAWN BY: EMM 1/14/2021	 LaserLinc, Inc. Phone: 888-707-4892 Info@laserlinc.com www.laserlinc.com			
	INTERPRET GEOMETRIC TOLERANCING PER: ASME Y14.5	TITLE: 1120-0000-31 AXION1120 WINDOW GUARD OVERALLS				
	MATERIAL FINISH DO NOT SCALE DRAWING	63 RA SURFACE FINISH ALL FEATURES MUST MEET SPECIFICATION AFTER PLATING BEFORE POWDER-COAT IF PLATED OR POWDER-COATED SEE FINISH		SIZE B	DWG. NO. 1120-0000-31	REV A
	SCALE: 1:3			SHEET 2 OF 2		