

8

7

6

5

4

3

2

1

F

E

D

C

B

A

F

E

D

C

B

A

REVISIONS				
ZONE	REV.	DESCRIPTION	DATE	APPROVED
	A	CHECK-IN	6/15/2023	CJM

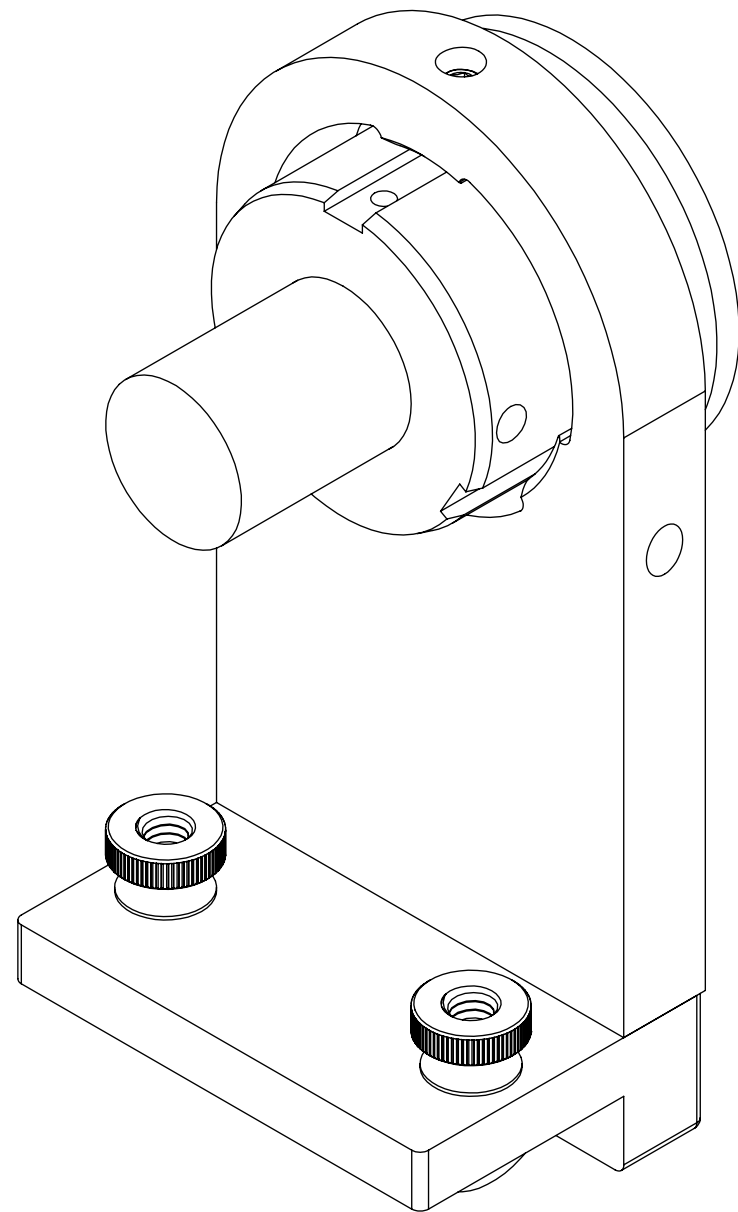

ADVANCED CALIBRATION STANDARDS FOR AXION130 GAUGE

INDEX

- (1) COVER PAGE
- (2) BOM TABLE
- (3) ASSEMBLE CALIBRATION FIXTURE
- (4) 1.000" CONFIGURATION
- (5) 0.250" CONFIGURATION
- (6) 0.0625" CONFIGURATION
- (7) 0.015" CONFIGURATION
- (8) MOUNT CALIBRATION FIXTURE
- (9) FIXTURE OVERALLS
- (10) MOUNTED OVERALLS

GENERAL FINISH NOTE		UNLESS OTHERWISE SPECIFIED:		NAME	DATE
DE-BURR AND BREAK		DIMENSIONS ARE IN INCHES		DRAWN BY:	CJM
ALL SHARP EDGES		TOLERANCES:			06/14/2023
BEFORE FINISH AND/OR SHIPPING		ANGLES ±.25°			
PROPRIETARY AND CONFIDENTIAL		TWO PLACE DECIMAL ±0.010			
THE INFORMATION CONTAINED IN THIS DRAWING IS THE SOLE PROPERTY OF LASERLINC, INC. ANY REPRODUCTION IN PART OR AS A WHOLE WITHOUT THE WRITTEN PERMISSION OF LASERLINC, INC. IS PROHIBITED.		THREE PLACE DECIMAL ±0.005			
		FOUR PLACE DECIMAL ±0.0005			
		UNMARKED FILLETS/CHAMFER .06			
		DE-BURR ALL PARTS			
		INTERPRET GEOMETRIC TOLERANCING PER: ASME Y14.5			
		MATERIAL			
		FINISH			
		DO NOT SCALE DRAWING			
		63 RA SURFACE FINISH			
		ALL FEATURES MUST MEET SPECIFICATION AFTER PLATING BEFORE POWDER-COAT IF PLATED OR POWDER-COATED			
		SEE FINISH			
		Laserlinc		LASERLINC, INC. PHONE: 937-318-2440 INFO@LASERLINC.COM WWW.LASERLINC.COM	
		TITLE:		ADVANCED CALIBRATION STANDARDS FOR AXION130 GAUGE	
SIZE	DWG. NO.	REV			
B	0130-0002-34	A			
SCALE: 1:2		SHEET 1 OF 10			

8

7

6

5

4

3

2

1

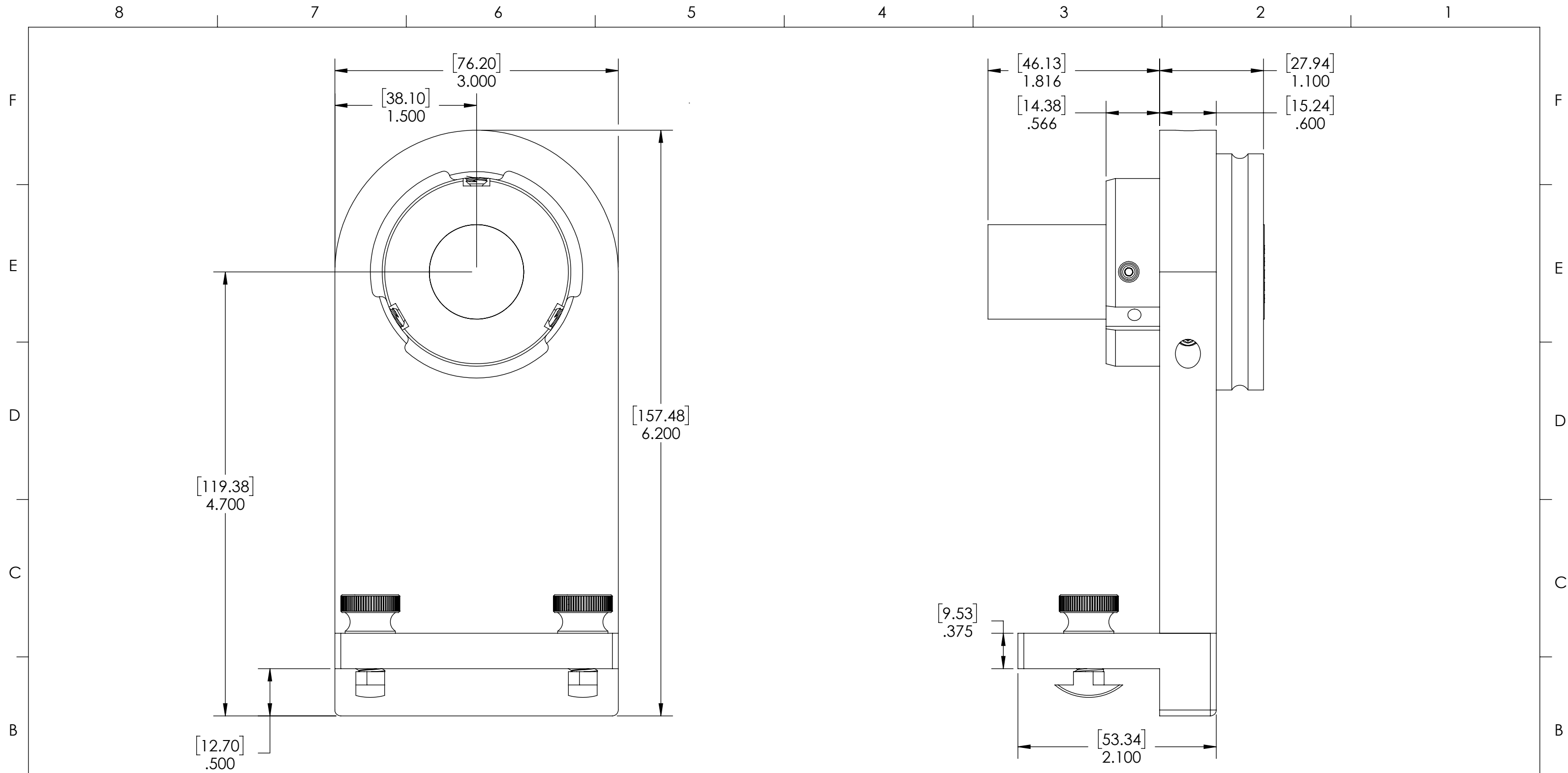

GENERAL FINISH NOTE DE-BURR AND BREAK ALL SHARP EDGES BEFORE FINISH AND/OR SHIPPING	UNLESS OTHERWISE SPECIFIED: DIMENSIONS ARE IN INCHES TOLERANCES: ANGLES ±.25° TWO PLACE DECIMAL ±0.010 THREE PLACE DECIMAL ±0.005 FOUR PLACE DECIMAL ±0.0005 UNMARKED FILLETS/CHAMFER .06 DE-BURR ALL PARTS	NAME: CJM DATE: 06/14/2023	 LASERLINC, INC. PHONE: 937-318-2440 INFO@LASERLINC.COM WWW.LASERLINC.COM
	PROPRIETARY AND CONFIDENTIAL THE INFORMATION CONTAINED IN THIS DRAWING IS THE SOLE PROPERTY OF LASERLINC, INC. ANY REPRODUCTION IN PART OR AS A WHOLE WITHOUT THE WRITTEN PERMISSION OF LASERLINC, INC. IS PROHIBITED.	INTERPRET GEOMETRIC TOLERANCING PER: ASME Y14.5 MATERIAL: FINISH: DO NOT SCALE DRAWING	
63 RA SURFACE FINISH ALL FEATURES MUST MEET SPECIFICATION AFTER PLATING BEFORE POWDER-COAT IF PLATED OR POWDER-COATED SEE FINISH		SIZE: B DWG. NO.: 0130-0002-34 SCALE: 1:2	REV: A SHEET 9 OF 10

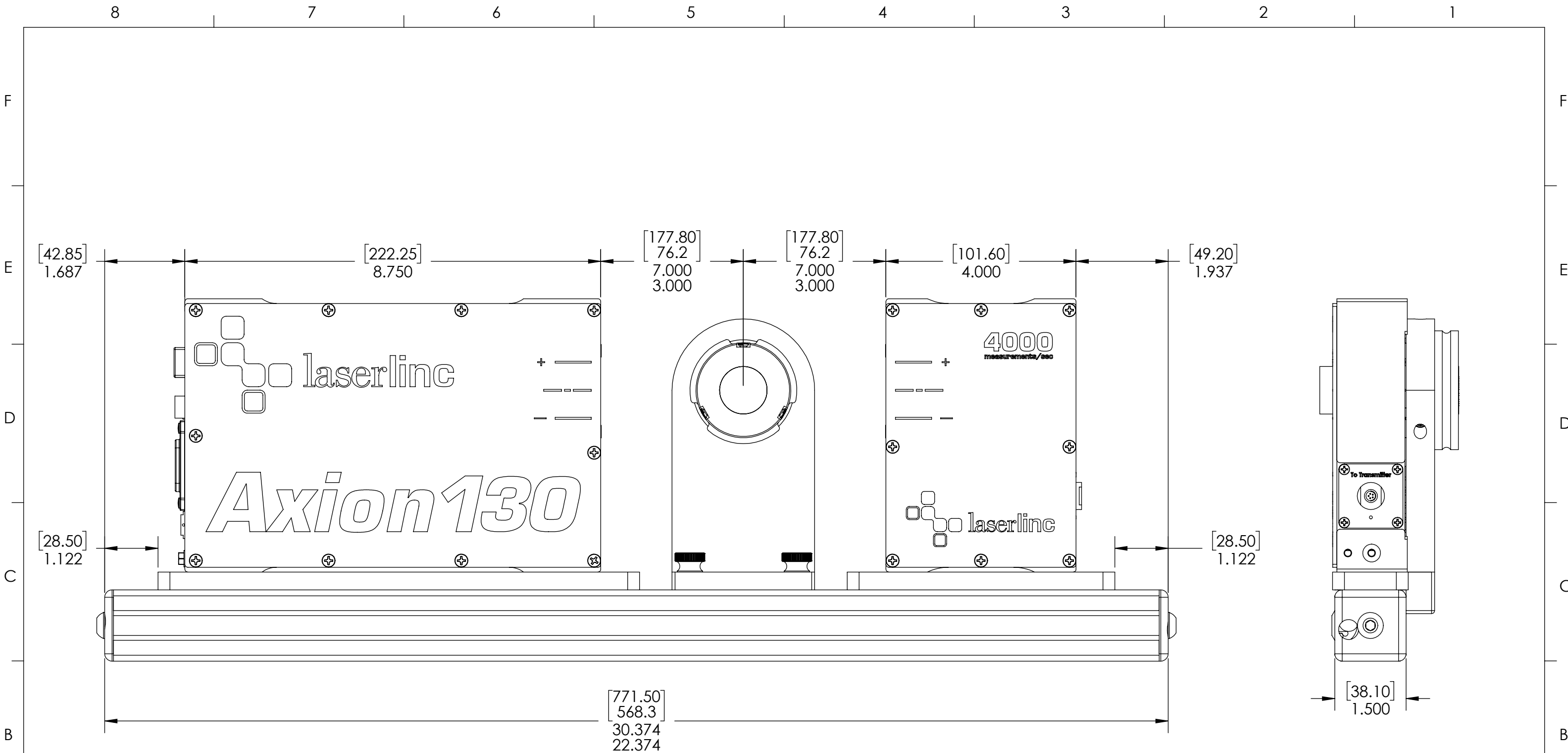

[771.50]
568.3
30.374
22.374

[28.50]
1.122

[38.10]
1.500

GENERAL FINISH NOTE DE-BURR AND BREAK ALL SHARP EDGES BEFORE FINISH AND/OR SHIPPING	UNLESS OTHERWISE SPECIFIED: DIMENSIONS ARE IN INCHES TOLERANCES: ANGLES ±.25 TWO PLACE DECIMAL ±0.010 THREE PLACE DECIMAL ±0.005 FOUR PLACE DECIMAL ±0.0005 UNMARKED FILLETS/CHAMFER .06 DE-BURR ALL PARTS	NAME CJM	DATE 06/14/2023		LASERLINC, INC. PHONE: 937-318-2440 INFO@LASERLINC.COM WWW.LASERLINC.COM		
	PROPRIETARY AND CONFIDENTIAL THE INFORMATION CONTAINED IN THIS DRAWING IS THE SOLE PROPERTY OF LASERLINC, INC. ANY REPRODUCTION IN PART OR AS A WHOLE WITHOUT THE WRITTEN PERMISSION OF LASERLINC, INC. IS PROHIBITED.	INTERPRET GEOMETRIC TOLERANCING PER: ASME Y14.5 MATERIAL FINISH DO NOT SCALE DRAWING	DRAWN BY: 				TITLE: ADVANCED CALIBRATION STANDARDS FOR AXION130 GAUGE
63 RA SURFACE FINISH ALL FEATURES MUST MEET SPECIFICATION AFTER PLATING BEFORE POWDER-COAT IF PLATED OR POWDER-COATED SEE FINISH				SCALE: 1:2		SHEET 10 OF 10	