

8

7

6

5

4

3

2

1

| REVISIONS | | | | |
|-----------|------|-------------|-----------|----------|
| ZONE | REV. | DESCRIPTION | DATE | APPROVED |
| | A | CHECK IN | 2/15/2021 | JWB |

F

F

E

E

D

D

C

C

B

B

A

A

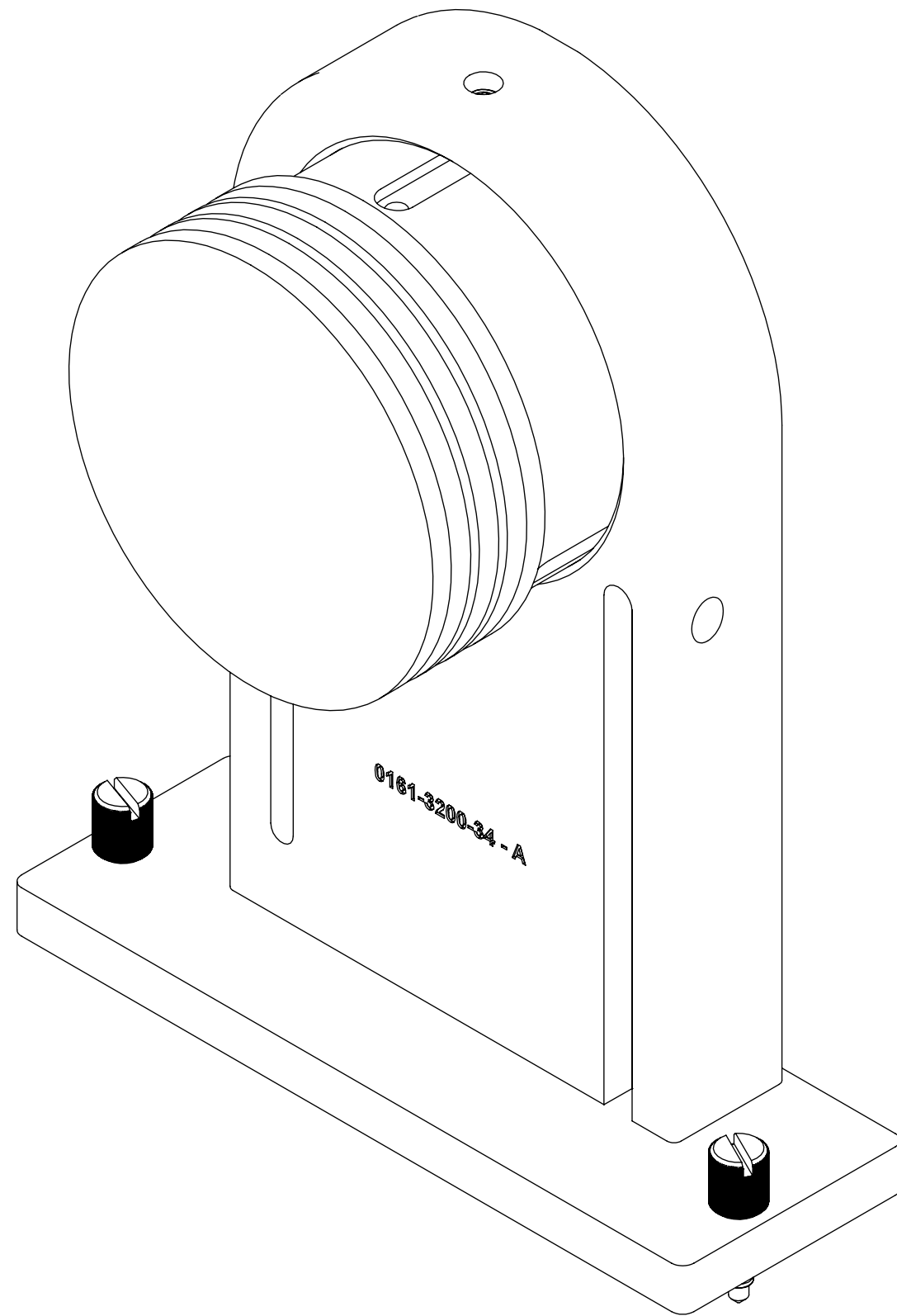

BenchLincOD ID, Axion160 Calibration Fixture Overalls

INDEX

- (1) COVER PAGE
- (2) FIXTURE DIMENSIONS
- (3) MOUNTED DIMENSIONS

| | | | | | | |
|---|--|--|--|---|------|---|
| GENERAL FINISH NOTE | | UNLESS OTHERWISE SPECIFIED: | | NAME | DATE |  LaserLinc, Inc. Phone: 888-707-4892 Info@laserlinc.com www.laserlinc.com |
| DE-BURR AND BREAK ALL SHARP EDGES BEFORE FINISH AND/OR SHIPPING | | DIMENSIONS ARE IN INCHES TOLERANCES: ANGLES ±.25° TWO PLACE DECIMAL ±0.010 THREE PLACE DECIMAL ±0.005 FOUR PLACE DECIMAL ±0.0005 UNMARKED FILLETS/CHAMFER .06 DE-BURR ALL PARTS | | DRAWN BY: | JWB | |
| PROPRIETARY AND CONFIDENTIAL | | INTERPRET GEOMETRIC TOLERANCING PER: ASME Y14.5 | | | | |
| THE INFORMATION CONTAINED IN THIS DRAWING IS THE SOLE PROPERTY OF LASERLINC, INC. ANY REPRODUCTION IN PART OR AS A WHOLE WITHOUT THE WRITTEN PERMISSION OF LASERLINC, INC. IS PROHIBITED. | | MATERIAL | | 63 RA SURFACE FINISH ALL FEATURES MUST MEET SPECIFICATION AFTER PLATING BEFORE POWDER-COAT IF PLATED OR POWDER-COATED SEE FINISH | | TITLE: |
| | | FINISH | | | | 6500-0001-34 BenchLincOD_ID, Axion160 Calibration Fixture Overalls |
| | | DO NOT SCALE DRAWING | | | | SIZE B |
| | | | | | | DWG. NO. 6500-0001-34 |
| | | | | | | REV A |
| | | | | | | SCALE: 1:1 |
| | | | | | | SHEET 1 OF 3 |

8

7

6

5

4

3

2

1

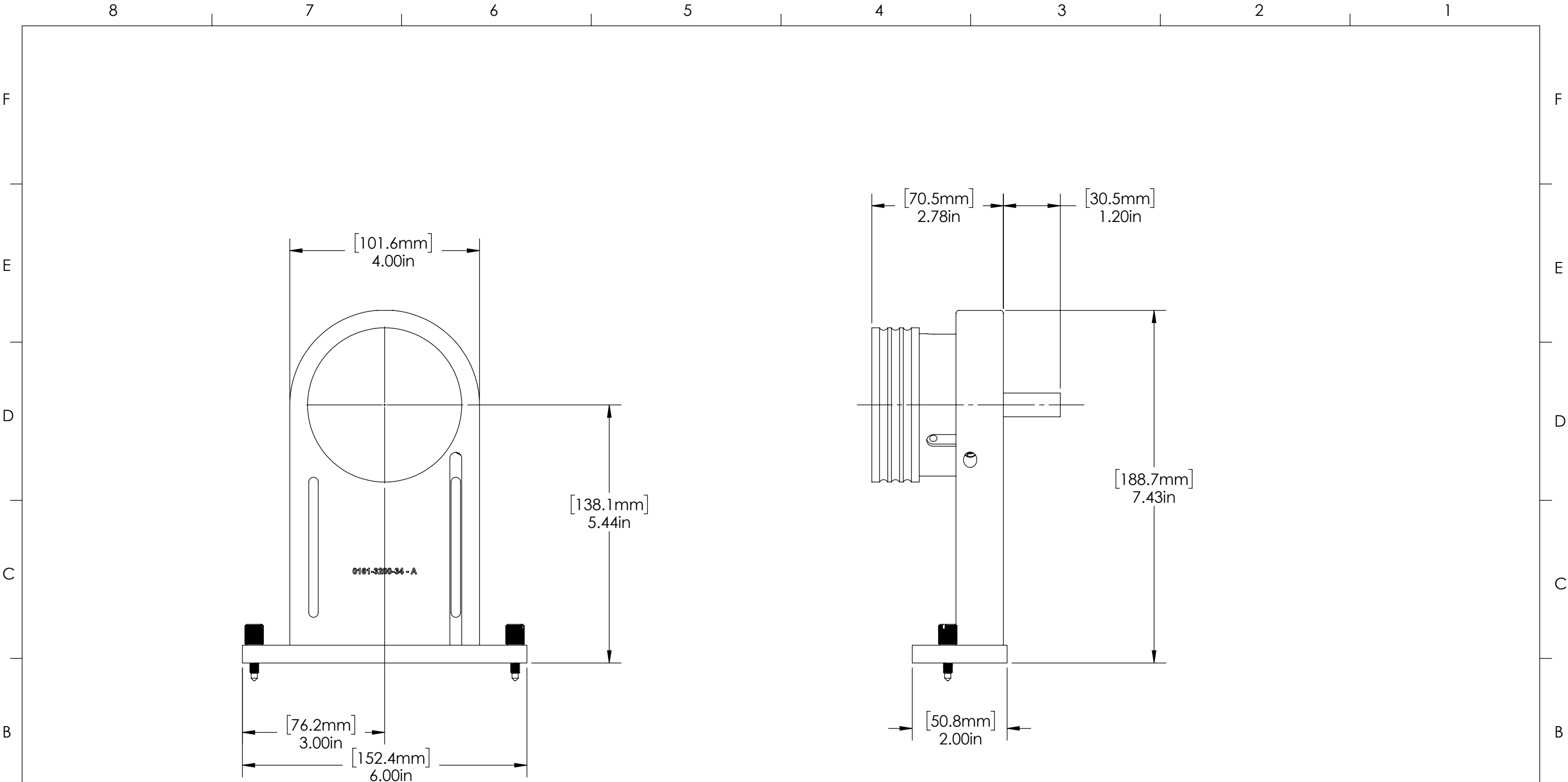

0161-3200-34 - A

| | | | | | |
|---|--------------|---|--|--|------|
| GENERAL FINISH NOTE | | UNLESS OTHERWISE SPECIFIED: | | NAME | DATE |
| DE-BURR AND BREAK ALL SHARP EDGES BEFORE FINISH AND/OR SHIPPING | | DIMENSIONS ARE IN INCHES TOLERANCES: ANGLES ±.25 TWO PLACE DECIMAL ±0.010 THREE PLACE DECIMAL ±0.005 FOUR PLACE DECIMAL ±0.0005 UNMARKED FILLETS/CHAMFER .06 DE-BURR ALL PARTS | | DRAWN BY: | JWB |
| | | INTERPRET GEOMETRIC TOLERANCING PER: ASME Y14.5 | | | |
| PROPRIETARY AND CONFIDENTIAL THE INFORMATION CONTAINED IN THIS DRAWING IS THE SOLE PROPERTY OF LASERLINC, INC. ANY REPRODUCTION IN PART OR AS A WHOLE WITHOUT THE WRITTEN PERMISSION OF LASERLINC, INC. IS PROHIBITED. | | MATERIAL FINISH DO NOT SCALE DRAWING | | 63 RA SURFACE FINISH ALL FEATURES MUST MEET SPECIFICATION AFTER PLATING BEFORE POWDER-COAT IF PLATED OR POWDER-COATED SEE FINISH | |
| | |  | | LASERLINC, INC. PHONE: 888-707-4892 INFO@LASERLINC.COM WWW.LASERLINC.COM | |
| | | TITLE: 6500-0001-34 BENCHLINCOD_ID, AXION160 CALIBRATION FIXTURE OVERALLS | | | |
| SIZE | DWG. NO. | REV | | | |
| B | 6500-0001-34 | A | | | |
| SCALE: 1:2 | | SHEET 2 OF 3 | | | |

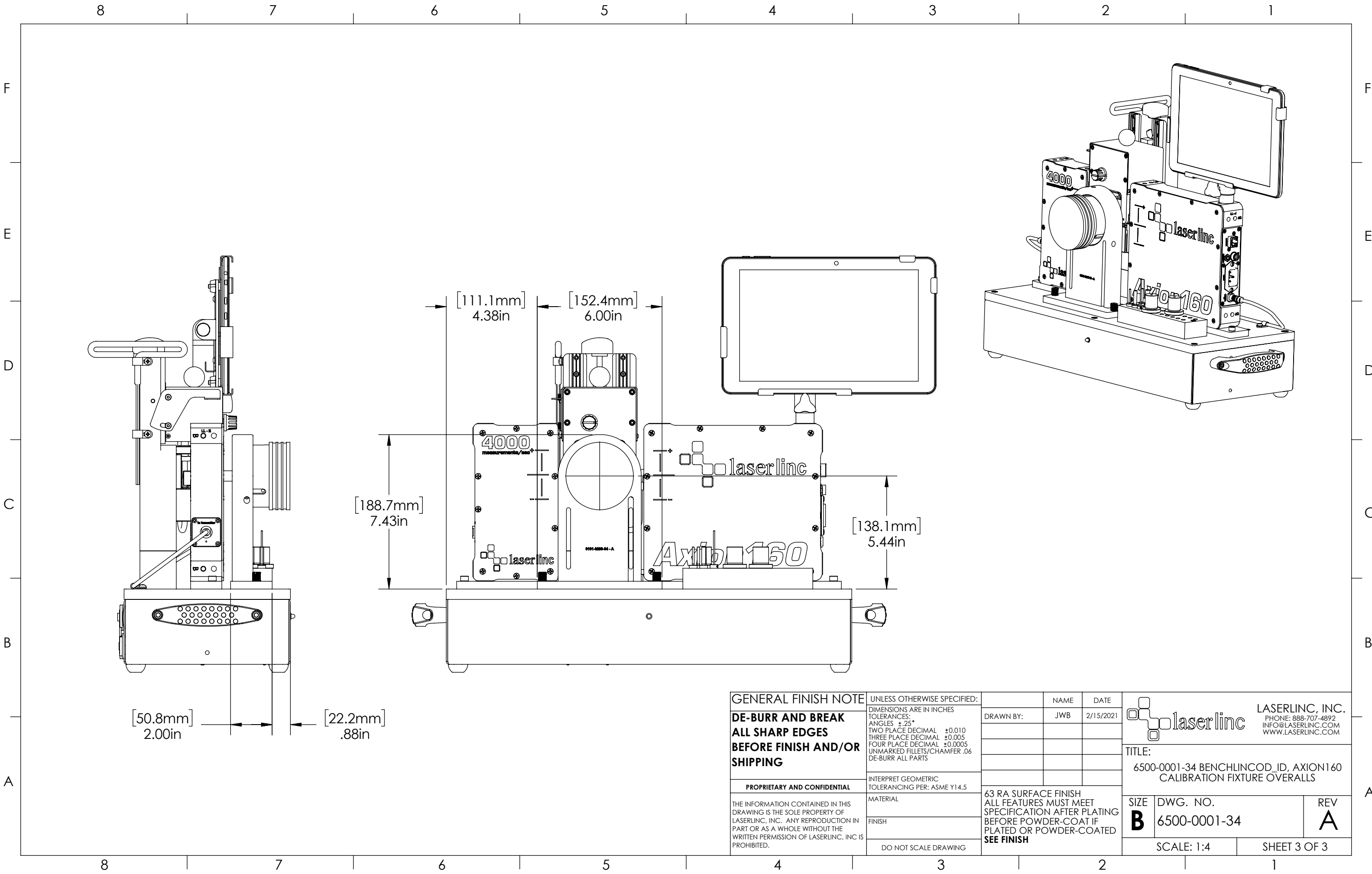

GENERAL FINISH NOTE
DE-BURR AND BREAK
ALL SHARP EDGES
BEFORE FINISH AND/OR
SHIPPING

PROPRIETARY AND CONFIDENTIAL
 THE INFORMATION CONTAINED IN THIS DRAWING IS THE SOLE PROPERTY OF LASERLINC, INC. ANY REPRODUCTION IN PART OR AS A WHOLE WITHOUT THE WRITTEN PERMISSION OF LASERLINC, INC. IS PROHIBITED.

UNLESS OTHERWISE SPECIFIED:
 DIMENSIONS ARE IN INCHES
 TOLERANCES:
 ANGLES ±.25°
 TWO PLACE DECIMAL ±0.010
 THREE PLACE DECIMAL ±0.005
 FOUR PLACE DECIMAL ±0.0005
 UNMARKED FILLETS/CHAMFER .06
 DE-BURR ALL PARTS
 INTERPRET GEOMETRIC TOLERANCING PER: ASME Y14.5
 MATERIAL
 FINISH
 DO NOT SCALE DRAWING

| | |
|---|-----------|
| NAME | DATE |
| DRAWN BY: JWV | 2/15/2021 |
| 63 RA SURFACE FINISH ALL FEATURES MUST MEET SPECIFICATION AFTER PLATING BEFORE POWDER-COAT IF PLATED OR POWDER-COATED SEE FINISH | |

| | | | |
|---|-----------------|--|--|
|  | | LASERLINC, INC. PHONE: 888-707-4892 INFO@LASERLINC.COM WWW.LASERLINC.COM | |
| TITLE: 6500-0001-34 BENCHLINCOD_ID, AXION160 CALIBRATION FIXTURE OVERALLS | | | |
| SIZE | DWG. NO. | REV | |
| B | 6500-0001-34 | A | |
| SCALE: 1:4 | | SHEET 3 OF 3 | |