

8

7

6

5

4

3

2

1

| ZONE | | REV. | DESCRIPTION | DATE | APPROVED |
|------|--|------|-------------|----------|----------|
| | | A | Check-In | 9/9/2013 | MAM |

F

F

E

E

D

D

C

C

B

B

A

A

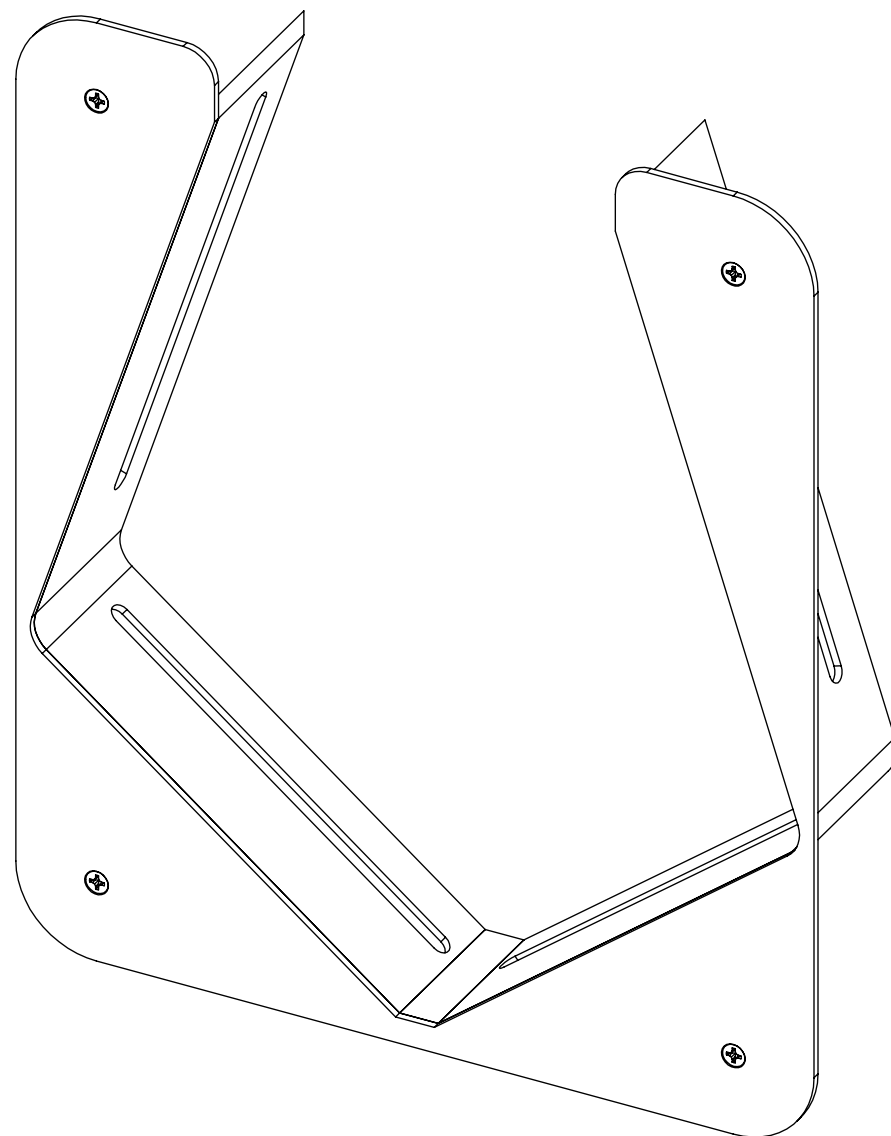

AXION2120 WINDOW GUARD OVERALLS

INDEX

- (1) COVER PAGE
- (2) DIMENSIONS

| | | | | | | |
|---|--|--|--|--|--------------|---|
| GENERAL FINISH NOTE | | UNLESS OTHERWISE SPECIFIED: | | NAME | DATE |  LaserLinc, Inc. Phone: 888-707-4892 info@laserlinc.com www.laserlinc.com |
| DE-BURR AND BREAK ALL SHARP EDGES BEFORE FINISH AND/OR SHIPPING | | DIMENSIONS ARE IN INCHES TOLERANCES: ANGLES ±.25° TWO PLACE DECIMAL ±0.010 THREE PLACE DECIMAL ±0.005 FOUR PLACE DECIMAL ±0.0005 UNMARKED FILLETS/CHAMFER .06 DE-BURR ALL PARTS | | DRAWN BY: | EMM | |
| PROPRIETARY AND CONFIDENTIAL THE INFORMATION CONTAINED IN THIS DRAWING IS THE SOLE PROPERTY OF LASERLINC, INC. ANY REPRODUCTION IN PART OR AS A WHOLE WITHOUT THE WRITTEN PERMISSION OF LASERLINC, INC. IS PROHIBITED. | | INTERPRET GEOMETRIC TOLERANCING PER: ASME Y14.5 MATERIAL FINISH DO NOT SCALE DRAWING | | 63 RA SURFACE FINISH ALL FEATURES MUST MEET SPECIFICATION AFTER PLATING BEFORE POWDER-COAT IF PLATED OR POWDER-COATED SEE FINISH | | TITLE: 2120-0000-31 AXION2120 WINDOW GUARD OVERALLS |
| | | | | SIZE | DWG. NO. | REV |
| | | | | B | 2120-0000-31 | A |
| | | | | SCALE: 1:2 | | SHEET 1 OF 2 |

8

7

6

5

4

3

2

1

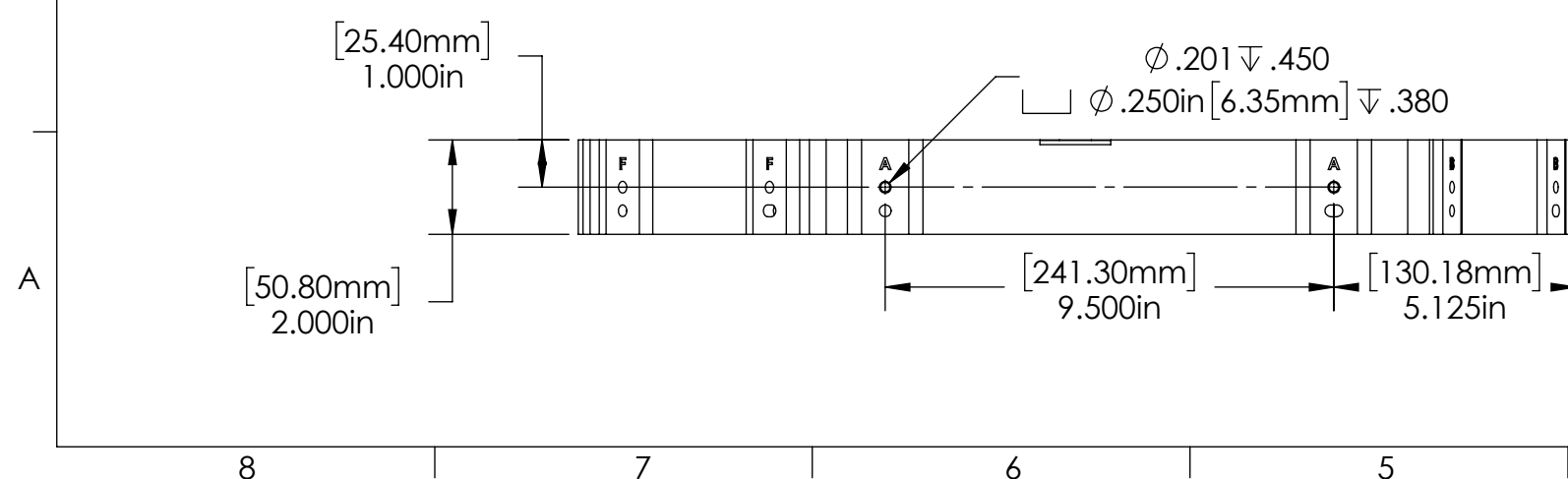
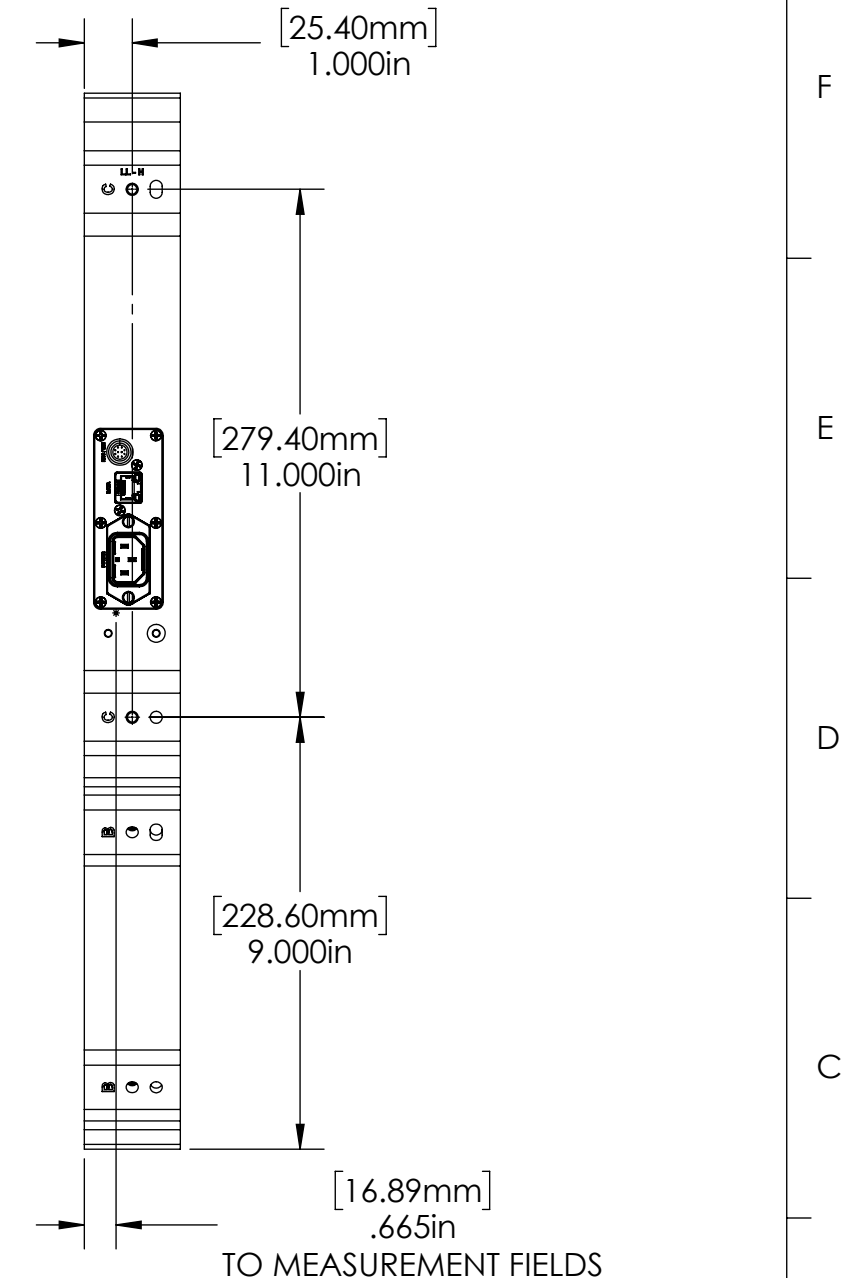
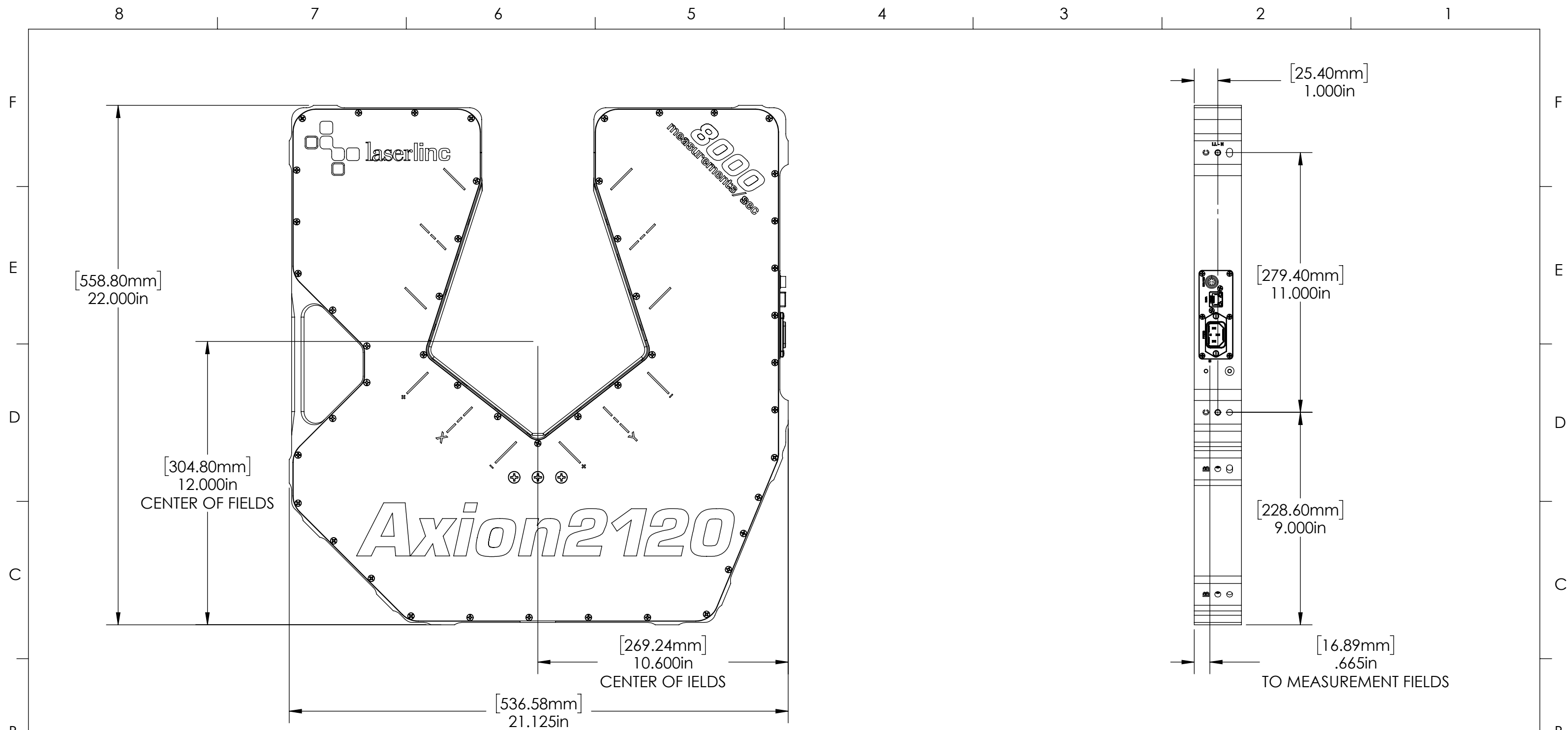

| | | | | |
|---|---|---|--------------|---|
| GENERAL FINISH NOTE DE-BURR AND BREAK ALL SHARP EDGES BEFORE FINISH AND/OR SHIPPING | UNLESS OTHERWISE SPECIFIED: DIMENSIONS ARE IN INCHES TOLERANCES: ANGLES ±.25° TWO PLACE DECIMAL ±0.010 THREE PLACE DECIMAL ±0.005 FOUR PLACE DECIMAL ±0.0005 UNMARKED FILLETS/CHAMFER .06 DE-BURR ALL PARTS | NAME | DATE | LaserLinc, Inc. Phone: 888-707-4892 Info@laserlinc.com www.laserlinc.com |
| | INTERPRET GEOMETRIC TOLERANCING PER: ASME Y14.5 | DRAWN BY: | EMM | |
| PROPRIETARY AND CONFIDENTIAL | MATERIAL | 63 RA SURFACE FINISH ALL FEATURES MUST MEET SPECIFICATION AFTER PLATING BEFORE POWDER-COAT IF PLATED OR POWDER-COATED SEE FINISH | | TITLE: 2120-0000-31 AXION2120 WINDOW GUARD OVERALLS |
| THE INFORMATION CONTAINED IN THIS DRAWING IS THE SOLE PROPERTY OF LASERLINC, INC. ANY REPRODUCTION IN PART OR AS A WHOLE WITHOUT THE WRITTEN PERMISSION OF LASERLINC, INC IS PROHIBITED. | FINISH | SIZE | DWG. NO. | REV |
| DO NOT SCALE DRAWING | | B | 2120-0000-31 | A |
| | | SCALE: 1:4 | | SHEET 2 OF 2 |