

8

7

6

5

4

3

2

1

ZONE		REV.	DESCRIPTION	DATE	APPROVED
		A	Check-In	11/15/2011	MAM

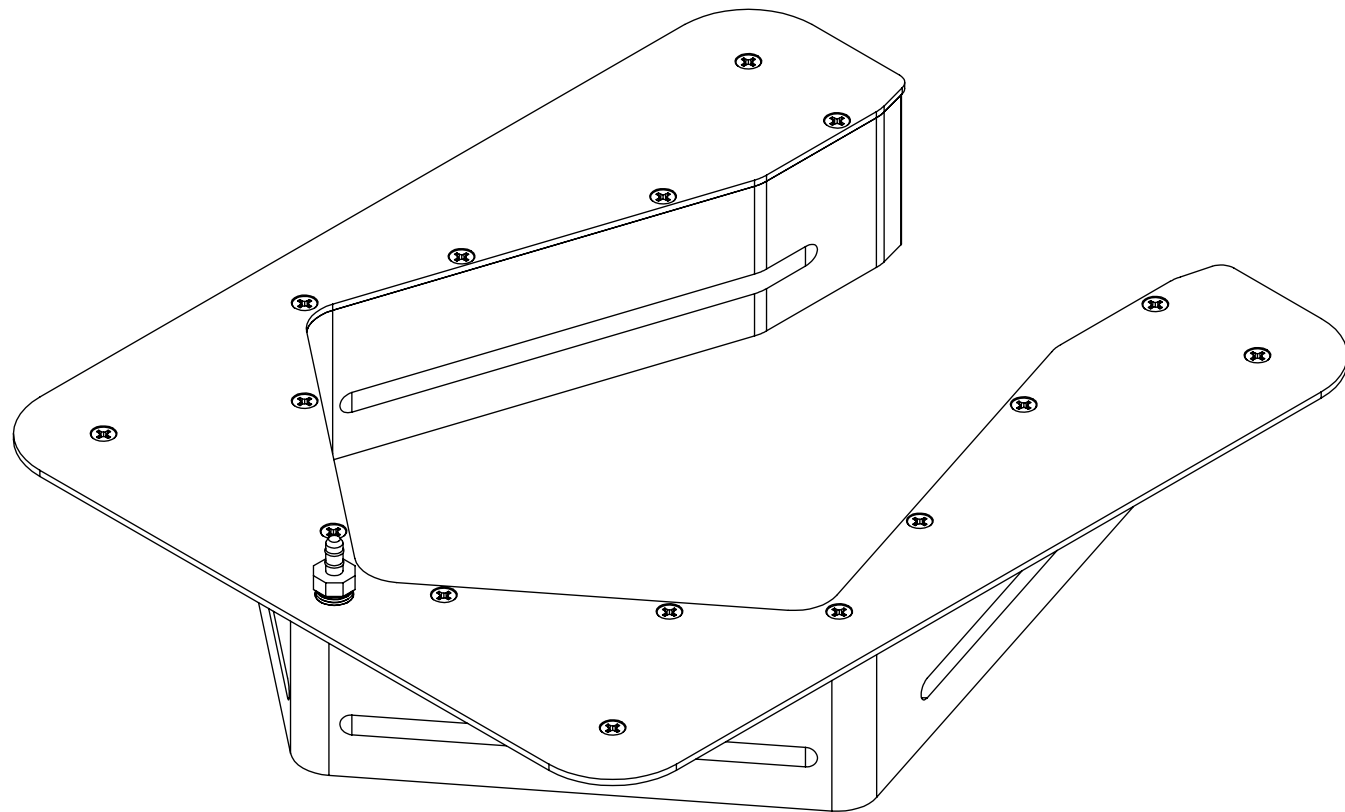

AXION2120 AIR PURGE FIXTURE OVERALLS

INDEX

- (1) COVER PAGE
- (2) FIXTURE DIMENSIONS
- (3) MOUNTED DIMENSIONS

GENERAL FINISH NOTE	UNLESS OTHERWISE SPECIFIED:	NAME	DATE	 LaserLinc, Inc. Phone: 888-707-4892 Info@laserlinc.com www.laserlinc.com
	DE-BURR AND BREAK ALL SHARP EDGES BEFORE FINISH AND/OR SHIPPING	DIMENSIONS ARE IN INCHES TOLERANCES: ANGLES ±.25 TWO PLACE DECIMAL ±0.010 THREE PLACE DECIMAL ±0.005 FOUR PLACE DECIMAL ±0.0005 UNMARKED FILLETS/CHAMFER .06 DE-BURR ALL PARTS	DRAWN BY:	
PROPRIETARY AND CONFIDENTIAL THE INFORMATION CONTAINED IN THIS DRAWING IS THE SOLE PROPERTY OF LASERLINC, INC. ANY REPRODUCTION IN PART OR AS A WHOLE WITHOUT THE WRITTEN PERMISSION OF LASERLINC, INC. IS PROHIBITED.	INTERPRET GEOMETRIC TOLERANCING PER: ASME Y14.5 MATERIAL FINISH DO NOT SCALE DRAWING	63 RA SURFACE FINISH ALL FEATURES MUST MEET SPECIFICATION AFTER PLATING BEFORE POWDER-COAT IF PLATED OR POWDER-COATED SEE FINISH		TITLE: 2120-0001-30 AXION2120 AIR PURGE FIXTURE OVERALLS
		SIZE	DWG. NO.	REV
		B	2120-0001-30	A
		SCALE: 1:2		SHEET 1 OF 3

8

7

6

5

4

3

2

1

F

E

D

C

B

A

F

E

D

C

B

A

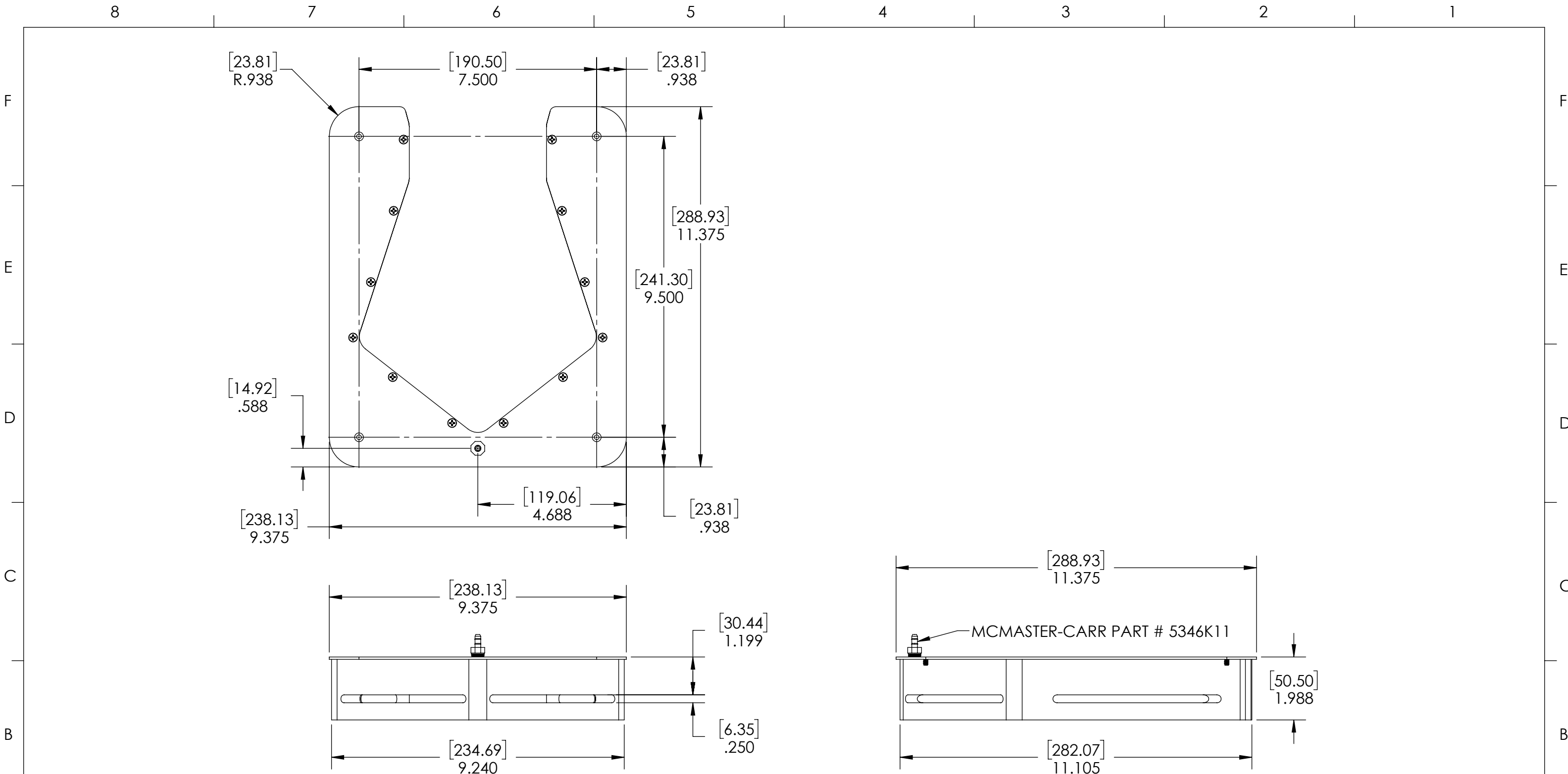

GENERAL FINISH NOTE DE-BURR AND BREAK ALL SHARP EDGES BEFORE FINISH AND/OR SHIPPING PROPRIETARY AND CONFIDENTIAL THE INFORMATION CONTAINED IN THIS DRAWING IS THE SOLE PROPERTY OF LASERLINC, INC. ANY REPRODUCTION IN PART OR AS A WHOLE WITHOUT THE WRITTEN PERMISSION OF LASERLINC, INC. IS PROHIBITED.	UNLESS OTHERWISE SPECIFIED: DIMENSIONS ARE IN INCHES TOLERANCES: ANGLES ±.25° TWO PLACE DECIMAL ±0.010 THREE PLACE DECIMAL ±0.005 FOUR PLACE DECIMAL ±0.0005 UNMARKED FILLETS/CHAMFER .06 DE-BURR ALL PARTS	NAME DATE	 LaserLinc, Inc. Phone: 888-707-4892 info@laserlinc.com www.laserlinc.com			
	INTERPRET GEOMETRIC TOLERANCING PER: ASME Y14.5	DRAWN BY: EMM DATE: 11/23/2020		TITLE: 2120-0001-30 AXION2120 AIR PURGE FIXTURE OVERALLS		
	MATERIAL	63 RA SURFACE FINISH ALL FEATURES MUST MEET SPECIFICATION AFTER PLATING BEFORE POWDER-COAT IF PLATED OR POWDER-COATED SEE FINISH		SIZE B	DWG. NO. 2120-0001-30	REV A
	FINISH DO NOT SCALE DRAWING	SCALE: 1:3		SHEET 2 OF 3		

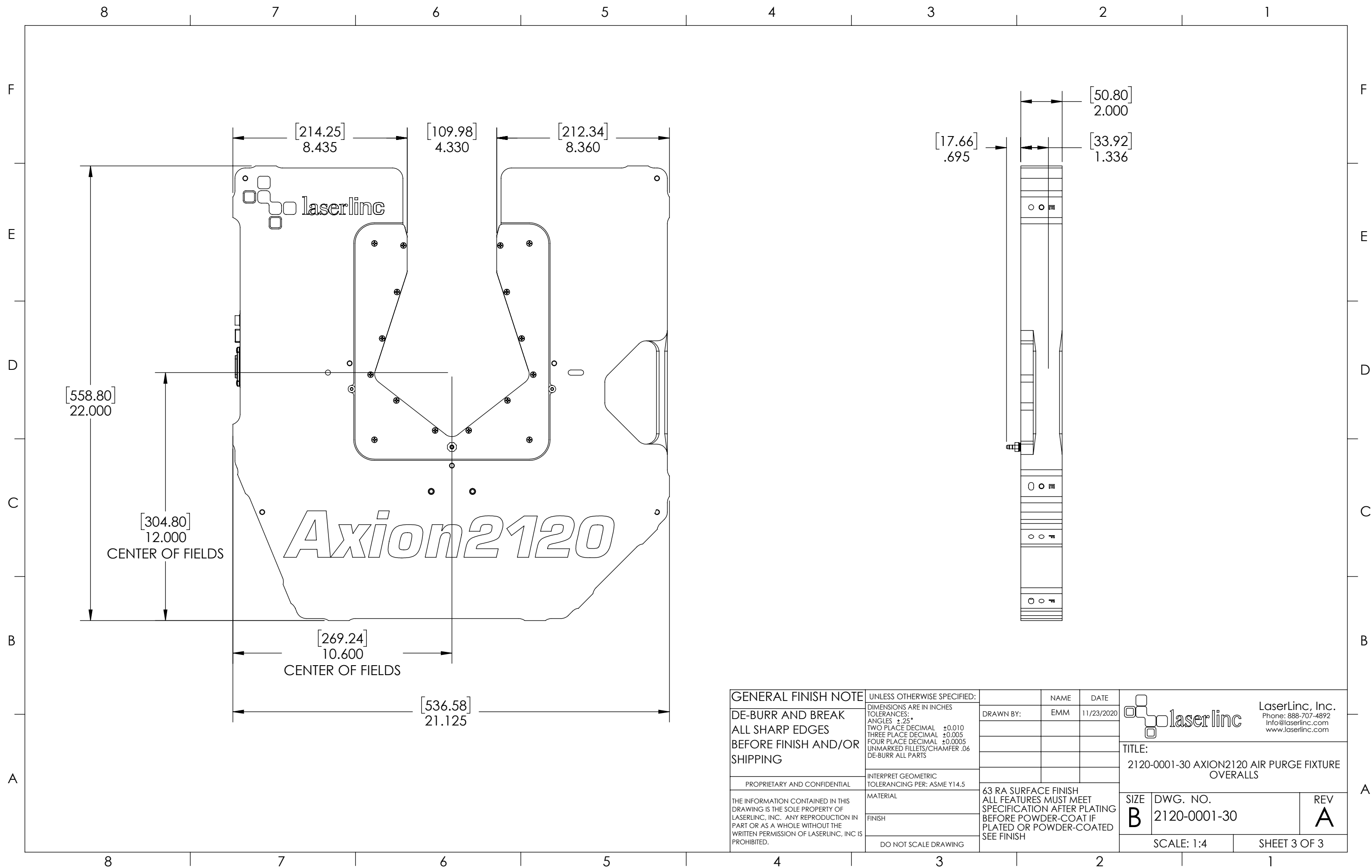

[558.80]
22.000

[304.80]
12.000
CENTER OF FIELDS

[269.24]
10.600
CENTER OF FIELDS

[536.58]
21.125

[214.25]
8.435

[109.98]
4.330

[212.34]
8.360

[17.66]
.695

[50.80]
2.000

[33.92]
1.336

Axion2120

laserlinc

GENERAL FINISH NOTE		UNLESS OTHERWISE SPECIFIED:		NAME	DATE	 LaserLinc, Inc. Phone: 888-707-4892 info@laserlinc.com www.laserlinc.com
DE-BURR AND BREAK ALL SHARP EDGES BEFORE FINISH AND/OR SHIPPING		DIMENSIONS ARE IN INCHES TOLERANCES: ANGLES ±.25° TWO PLACE DECIMAL ±0.010 THREE PLACE DECIMAL ±0.005 FOUR PLACE DECIMAL ±0.0005 UNMARKED FILLETS/CHAMFER .06 DE-BURR ALL PARTS		DRAWN BY:	EMM	
PROPRIETARY AND CONFIDENTIAL THE INFORMATION CONTAINED IN THIS DRAWING IS THE SOLE PROPERTY OF LASERLINC, INC. ANY REPRODUCTION IN PART OR AS A WHOLE WITHOUT THE WRITTEN PERMISSION OF LASERLINC, INC. IS PROHIBITED.		INTERPRET GEOMETRIC TOLERANCING PER: ASME Y14.5		63 RA SURFACE FINISH ALL FEATURES MUST MEET SPECIFICATION AFTER PLATING BEFORE POWDER-COAT IF PLATED OR POWDER-COATED SEE FINISH		TITLE: 2120-0001-30 AXION2120 AIR PURGE FIXTURE OVERALLS
		MATERIAL		SIZE B		DWG. NO. 2120-0001-30
		FINISH		REV A		SCALE: 1:4
		DO NOT SCALE DRAWING				SHEET 3 OF 3