

8

7

6

5

4

3

2

1

F

E

D

C

B

A

F

E

D

C

B

A

REVISIONS				
ZONE	REV.	DESCRIPTION	DATE	APPROVED
	A	CHECK-IN	8/13/2012	MAM

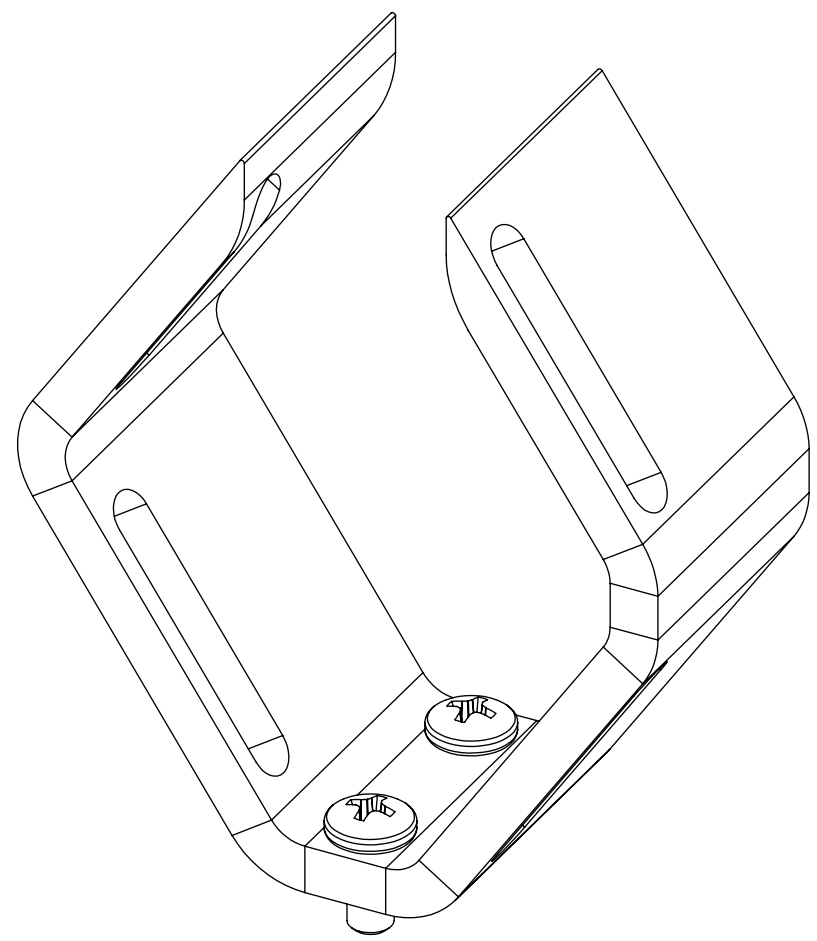

# AXION222 WINDOW GUARD OVERALLS

## INDEX

- (1) COVER PAGE
- (2) MOUNTED DIMENSIONS

<b>GENERAL FINISH NOTE</b>		UNLESS OTHERWISE SPECIFIED:		NAME	DATE	 <b>LaserLinc, Inc.</b> Phone: 888-707-4892 Info@laserlinc.com www.laserlinc.com
<b>DE-BURR AND BREAK ALL SHARP EDGES BEFORE FINISH AND/OR SHIPPING</b>		DIMENSIONS ARE IN INCHES TOLERANCES: ANGLES ±.25° TWO PLACE DECIMAL ±0.010 THREE PLACE DECIMAL ±0.005 FOUR PLACE DECIMAL ±0.0005 UNMARKED FILLETS/CHAMFER .06 DE-BURR ALL PARTS		DRAWN BY:	EMM	
PROPRIETARY AND CONFIDENTIAL  THE INFORMATION CONTAINED IN THIS DRAWING IS THE SOLE PROPERTY OF LASERLINC, INC. ANY REPRODUCTION IN PART OR AS A WHOLE WITHOUT THE WRITTEN PERMISSION OF LASERLINC, INC. IS PROHIBITED.		INTERPRET GEOMETRIC TOLERANCING PER: ASME Y14.5  MATERIAL  FINISH  DO NOT SCALE DRAWING		63 RA SURFACE FINISH ALL FEATURES MUST MEET SPECIFICATION AFTER PLATING BEFORE POWDER-COAT IF PLATED OR POWDER-COATED SEE FINISH		TITLE: 0222-0000-31 AXION222 WINDOW GUARD OVERALLS
		SIZE	DWG. NO.	REV		
		<b>B</b>	0222-0000-31	<b>A</b>		
		SCALE: 3:2		SHEET 1 OF 2		

8

7

6

5

4

3

2

1

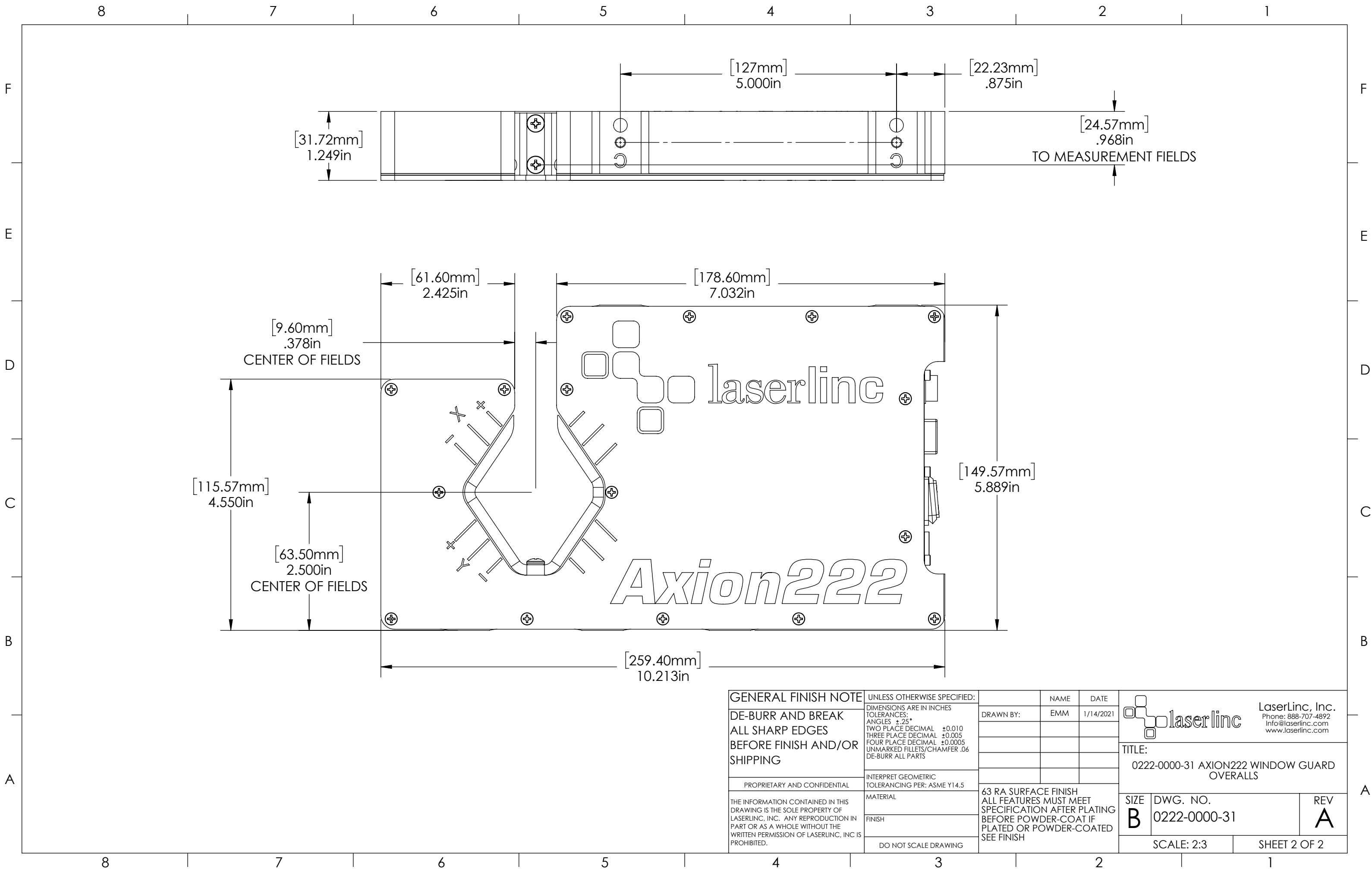

**GENERAL FINISH NOTE**

DE-BURR AND BREAK  
ALL SHARP EDGES  
BEFORE FINISH AND/OR  
SHIPPING

PROPRIETARY AND CONFIDENTIAL

THE INFORMATION CONTAINED IN THIS  
DRAWING IS THE SOLE PROPERTY OF  
LASERLINC, INC. ANY REPRODUCTION IN  
PART OR AS A WHOLE WITHOUT THE  
WRITTEN PERMISSION OF LASERLINC, INC. IS  
PROHIBITED.

**UNLESS OTHERWISE SPECIFIED:**

DIMENSIONS ARE IN INCHES  
TOLERANCES:  
ANGLES ±.25  
TWO PLACE DECIMAL ±0.010  
THREE PLACE DECIMAL ±0.005  
FOUR PLACE DECIMAL ±0.0005  
UNMARKED FILLETS/CHAMFER .06  
DE-BURR ALL PARTS

INTERPRET GEOMETRIC  
TOLERANCING PER: ASME Y14.5

MATERIAL

FINISH

DO NOT SCALE DRAWING

NAME	DATE
EMM	1/14/2021

63 RA SURFACE FINISH  
ALL FEATURES MUST MEET  
SPECIFICATION AFTER PLATING  
BEFORE POWDER-COAT IF  
PLATED OR POWDER-COATED  
SEE FINISH



**LaserLinc, Inc.**  
Phone: 888-707-4892  
Info@laserlinc.com  
www.laserlinc.com

TITLE:  
0222-0000-31 AXION222 WINDOW GUARD  
OVERALLS

SIZE	DWG. NO.	REV
B	0222-0000-31	A

SCALE: 2:3 SHEET 2 OF 2