

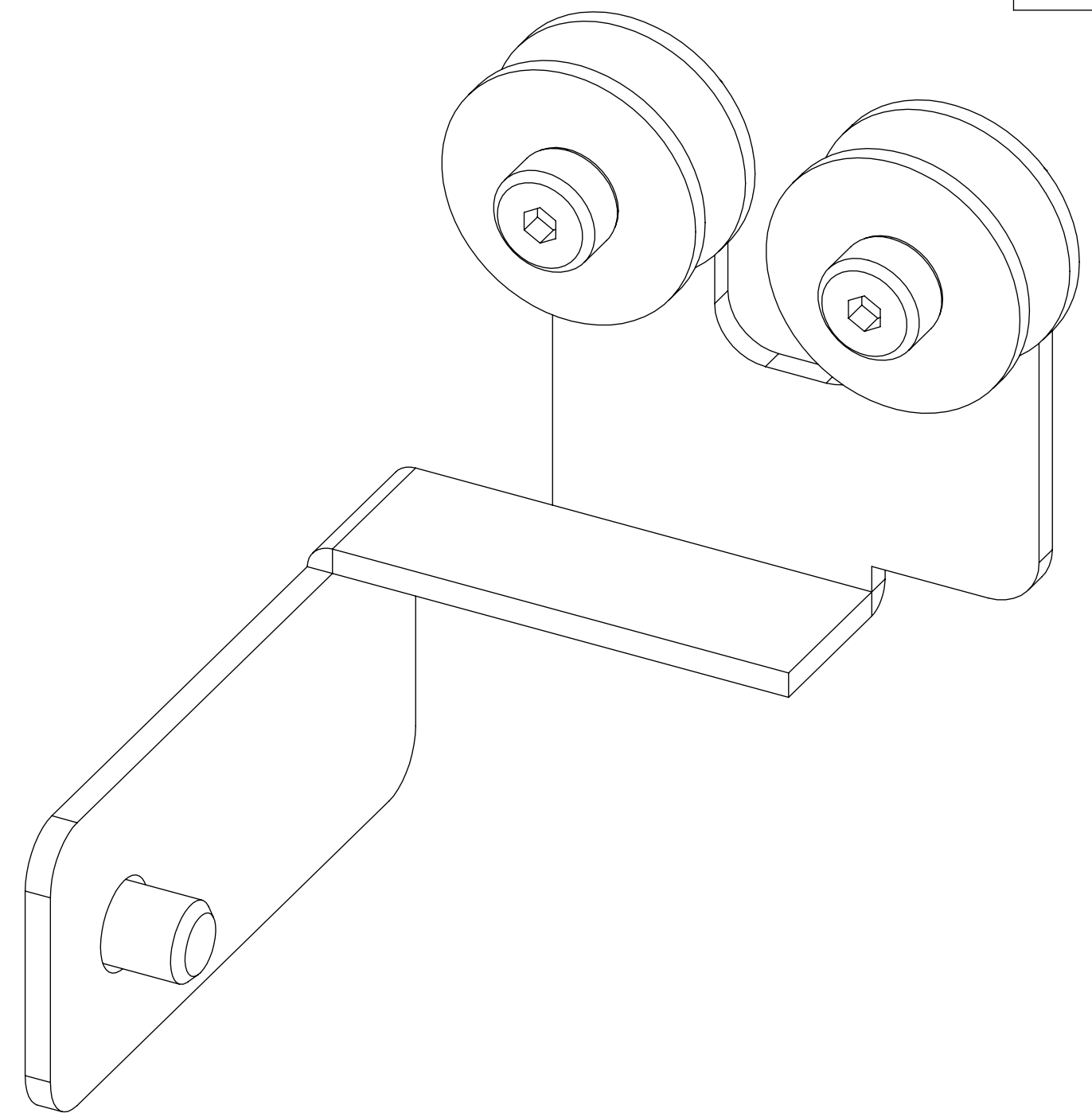

REVISIONS

ZONE	REV.	DESCRIPTION	DATE	APPROVED
	A	Check-in	12/20/2011	ZRP
	B	Added a nut	12/9/2013	MAM



# AXION222 THROAT MOUNT ROLLER GUIDE OVERALLS

**INDEX**  
 (1) COVER PAGE  
 (2) FIXTURE DIMENSIONS

<b>GENERAL FINISH NOTE</b> <b>DE-BURR AND BREAK</b> <b>ALL SHARP EDGES</b> <b>BEFORE FINISH AND/OR SHIPPING</b>	UNLESS OTHERWISE SPECIFIED: DIMENSIONS ARE IN INCHES TOLERANCES: ANGLES ±.25° TWO PLACE DECIMAL ±0.010 THREE PLACE DECIMAL ±0.005 FOUR PLACE DECIMAL ±0.0005 UNMARKED FILLETS/CHAMFER .06 DE-BURR ALL PARTS	NAME EMM	DATE 12/14/2020	 LASERLINC, INC. PHONE: 888-707-4892 INFO@LASERLINC.COM WWW.LASERLINC.COM	
	PROPRIETARY AND CONFIDENTIAL THE INFORMATION CONTAINED IN THIS DRAWING IS THE SOLE PROPERTY OF LASERLINC, INC. ANY REPRODUCTION IN PART OR AS A WHOLE WITHOUT THE WRITTEN PERMISSION OF LASERLINC, INC. IS PROHIBITED.	INTERPRET GEOMETRIC TOLERANCING PER: ASME Y14.5 MATERIAL FINISH DO NOT SCALE DRAWING	DRAWN BY: EMM		TITLE: 0222-0000-60 AXION222 THROAT MOUNT ROLLER GUIDE OVERALLS
63 RA SURFACE FINISH ALL FEATURES MUST MEET SPECIFICATION AFTER PLATING BEFORE POWDER-COAT IF PLATED OR POWDER-COATED <b>SEE FINISH</b>			SIZE <b>B</b>	DWG. NO. 0222-0000-60	REV <b>B</b>
			SCALE: 3:1	SHEET 1 OF 2	

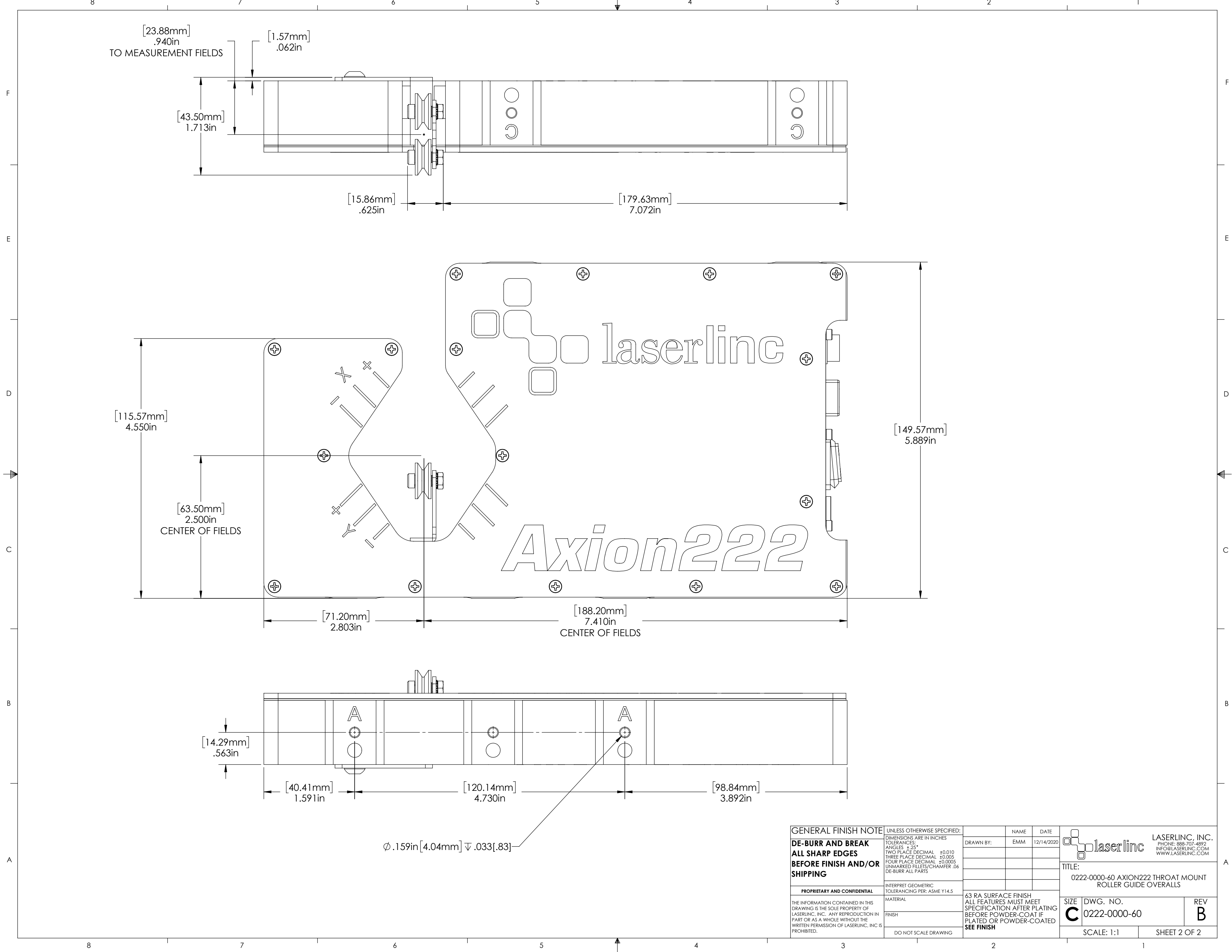

**GENERAL FINISH NOTE**  
**DE-BURR AND BREAK**  
**ALL SHARP EDGES**  
**BEFORE FINISH AND/OR**  
**SHIPPING**

UNLESS OTHERWISE SPECIFIED:  
 DIMENSIONS ARE IN INCHES  
 TOLERANCES:  
 ANGLES ±25°  
 TWO PLACE DECIMAL ±0.010  
 THREE PLACE DECIMAL ±0.005  
 FOUR PLACE DECIMAL ±0.0005  
 UNMARKED FILLETS/CHAMFER .06  
 DE-BURR ALL PARTS

INTERPRET GEOMETRIC  
 TOLERANCING PER: ASME Y14.5

MATERIAL

FINISH

DO NOT SCALE DRAWING

DRAWN BY: EMM		NAME	DATE
		EMM	12/14/2020
 <b>LASERLINC, INC.</b> PHONE: 888-707-4892 INFO@LASERLINC.COM WWW.LASERLINC.COM			
TITLE: 0222-0000-60 AXION222 THROAT MOUNT ROLLER GUIDE OVERALLS			
SIZE	DWG. NO.	REV	
<b>C</b>	0222-0000-60	<b>B</b>	
SCALE: 1:1		SHEET 2 OF 2	

PROPRIETARY AND CONFIDENTIAL

THE INFORMATION CONTAINED IN THIS DRAWING IS THE SOLE PROPERTY OF LASERLINC, INC. ANY REPRODUCTION IN PART OR AS A WHOLE WITHOUT THE WRITTEN PERMISSION OF LASERLINC, INC IS PROHIBITED.

63 RA SURFACE FINISH  
 ALL FEATURES MUST MEET  
 SPECIFICATION AFTER PLATING  
 BEFORE POWDER-COAT IF  
 PLATED OR POWDER-COATED  
**SEE FINISH**