

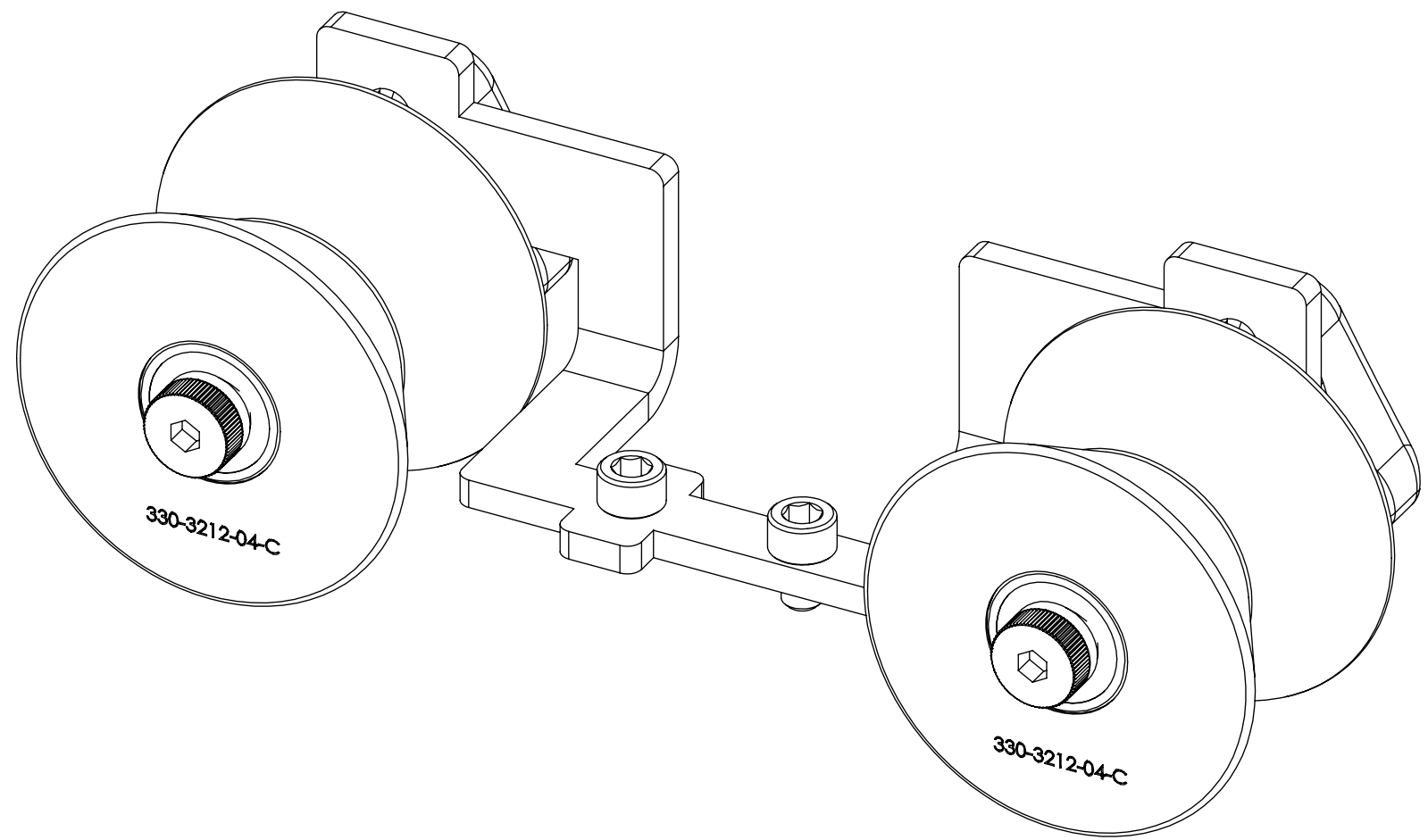

REVISIONS

ZONE	REV.	DESCRIPTION	DATE	APPROVED
	A	Check-In	3/31/2015	MAM



AXION222 MANUAL ADJUST MOUNT ROLLER GUIDE OVERALLS

INDEX
(1) COVER PAGE
(2) DIMENSIONS

GENERAL FINISH NOTE DE-BURR AND BREAK ALL SHARP EDGES BEFORE FINISH AND/OR SHIPPING	UNLESS OTHERWISE SPECIFIED: DIMENSIONS ARE IN INCHES TOLERANCES: ANGLES ±.25° TWO PLACE DECIMAL ±0.010 THREE PLACE DECIMAL ±0.005 FOUR PLACE DECIMAL ±0.0005 UNMARKED FILLETS/CHAMFER .06 DE-BURR ALL PARTS	NAME	DATE	 LASERLINC, INC. PHONE: 888-707-4892 INFO@LASERLINC.COM WWW.LASERLINC.COM		
		DRAWN BY:	EMM		12/16/2020	
PROPRIETARY AND CONFIDENTIAL THE INFORMATION CONTAINED IN THIS DRAWING IS THE SOLE PROPERTY OF LASERLINC, INC. ANY REPRODUCTION IN PART OR AS A WHOLE WITHOUT THE WRITTEN PERMISSION OF LASERLINC, INC. IS PROHIBITED.	INTERPRET GEOMETRIC TOLERANCING PER: ASME Y14.5 MATERIAL FINISH DO NOT SCALE DRAWING	TITLE: 0222-0000-66 AXION222 MANUAL ADJUST MOUNT ROLLER GUIDE OVERALLS		SIZE B	DWG. NO. 0222-0000-66	REV A
		SCALE: 3:2		SHEET 1 OF 2		

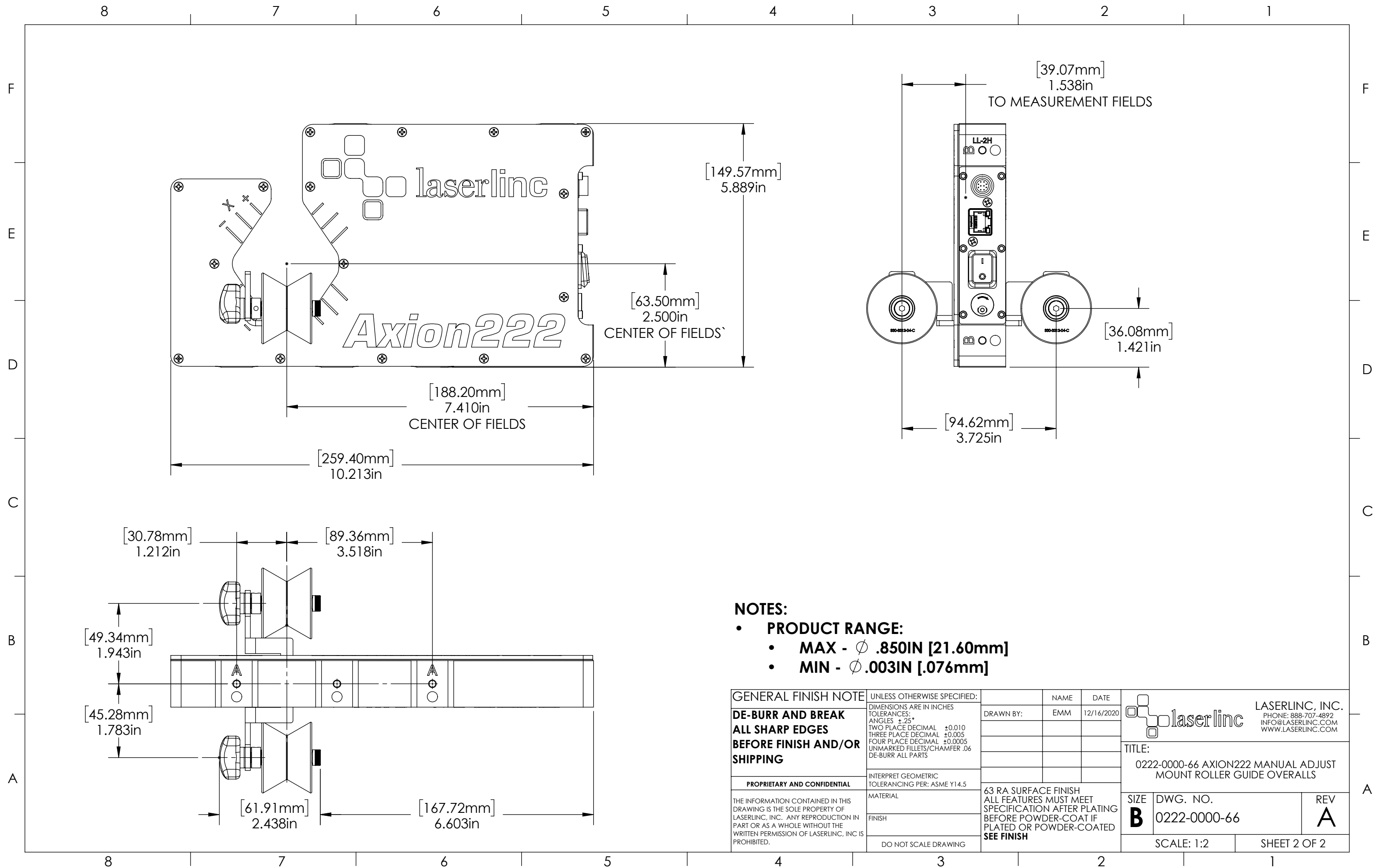

NOTES:

- **PRODUCT RANGE:**
 - **MAX - ϕ .850IN [21.60mm]**
 - **MIN - ϕ .003IN [.076mm]**

GENERAL FINISH NOTE		UNLESS OTHERWISE SPECIFIED:		NAME	DATE
DE-BURR AND BREAK ALL SHARP EDGES BEFORE FINISH AND/OR SHIPPING		DIMENSIONS ARE IN INCHES TOLERANCES: ANGLES \pm .25 TWO PLACE DECIMAL \pm 0.010 THREE PLACE DECIMAL \pm 0.005 FOUR PLACE DECIMAL \pm 0.0005 UNMARKED FILLETS/CHAMFER .06 DE-BURR ALL PARTS		DRAWN BY:	EMM 12/16/2020
PROPRIETARY AND CONFIDENTIAL		INTERPRET GEOMETRIC TOLERANCING PER: ASME Y14.5			
THE INFORMATION CONTAINED IN THIS DRAWING IS THE SOLE PROPERTY OF LASERLINC, INC. ANY REPRODUCTION IN PART OR AS A WHOLE WITHOUT THE WRITTEN PERMISSION OF LASERLINC, INC. IS PROHIBITED.		MATERIAL		63 RA SURFACE FINISH ALL FEATURES MUST MEET SPECIFICATION AFTER PLATING BEFORE POWDER-COAT IF PLATED OR POWDER-COATED SEE FINISH	
		FINISH		DO NOT SCALE DRAWING	
				LASERLINC, INC. PHONE: 888-707-4892 INFO@LASERLINC.COM WWW.LASERLINC.COM	
				TITLE: 0222-0000-66 AXION222 MANUAL ADJUST MOUNT ROLLER GUIDE OVERALLS	
		SIZE	DWG. NO.	REV	
		B	0222-0000-66	A	
		SCALE: 1:2		SHEET 2 OF 2	