

8 7 6 5 4 3 2 1

F  
E  
D  
C  
B  
A

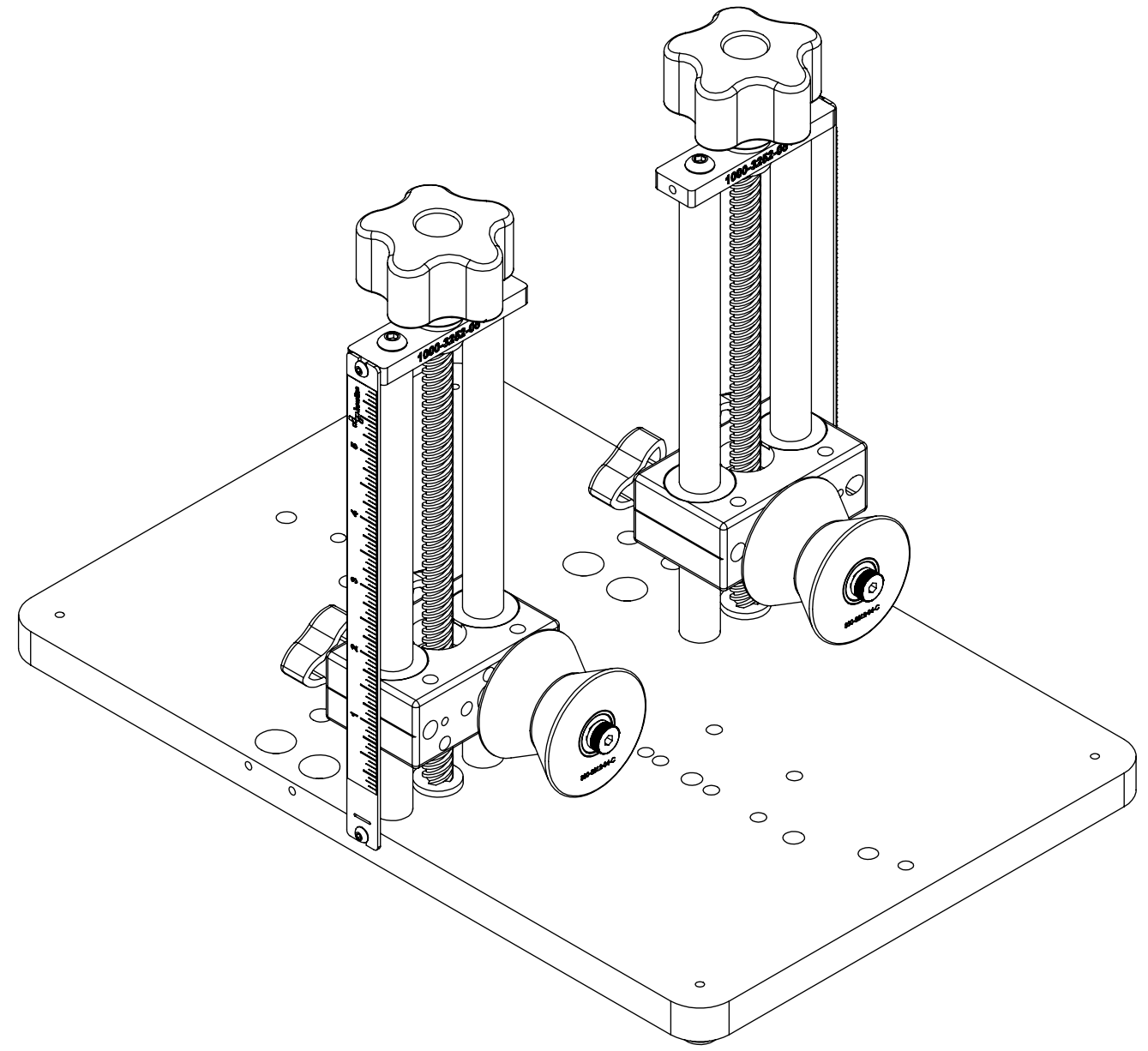

REVISIONS				
ZONE	REV.	DESCRIPTION	DATE	APPROVED
	A	CHECK-IN	10/5/2018	MAM

# X30 PLATE MOUNT ROLLER GUIDE, 7IN

## INDEX

- (1) COVER PAGE
- (2) FIXTURE DIMENSIONS

<b>GENERAL FINISH NOTE</b>		UNLESS OTHERWISE SPECIFIED:		NAME	DATE	 <b>LASERLINC, INC.</b> PHONE: 888-707-4892 INFO@LASERLINC.COM WWW.LASERLINC.COM
<b>DE-BURR AND BREAK ALL SHARP EDGES BEFORE FINISH AND/OR SHIPPING</b>		DIMENSIONS ARE IN INCHES TOLERANCES: ANGLES ±.25° TWO PLACE DECIMAL ±0.010 THREE PLACE DECIMAL ±0.005 FOUR PLACE DECIMAL ±0.0005 UNMARKED FILLETS/CHAMFER .06 DE-BURR ALL PARTS		DRAWN BY:	MWD 9/3/2021	
<b>PROPRIETARY AND CONFIDENTIAL</b>		INTERPRET GEOMETRIC TOLERANCING PER: ASME Y14.5				TITLE: 1000-0001-62 X30 PLATE MOUNT ROLLER GUIDE, 7IN MICROMETER OVERALL DIMENSIONS
THE INFORMATION CONTAINED IN THIS DRAWING IS THE SOLE PROPERTY OF LASERLINC, INC. ANY REPRODUCTION IN PART OR AS A WHOLE WITHOUT THE WRITTEN PERMISSION OF LASERLINC, INC. IS PROHIBITED.		MATERIAL		63 RA SURFACE FINISH ALL FEATURES MUST MEET SPECIFICATION AFTER PLATING BEFORE POWDER-COAT IF PLATED OR POWDER-COATED <b>SEE FINISH</b>		SIZE <b>B</b> DWG. NO. 1000-0001-62 REV <b>A</b>
		FINISH				SCALE: 1:2
		DO NOT SCALE DRAWING				SHEET 1 OF 5

8 7 6 5 4 3 2 1

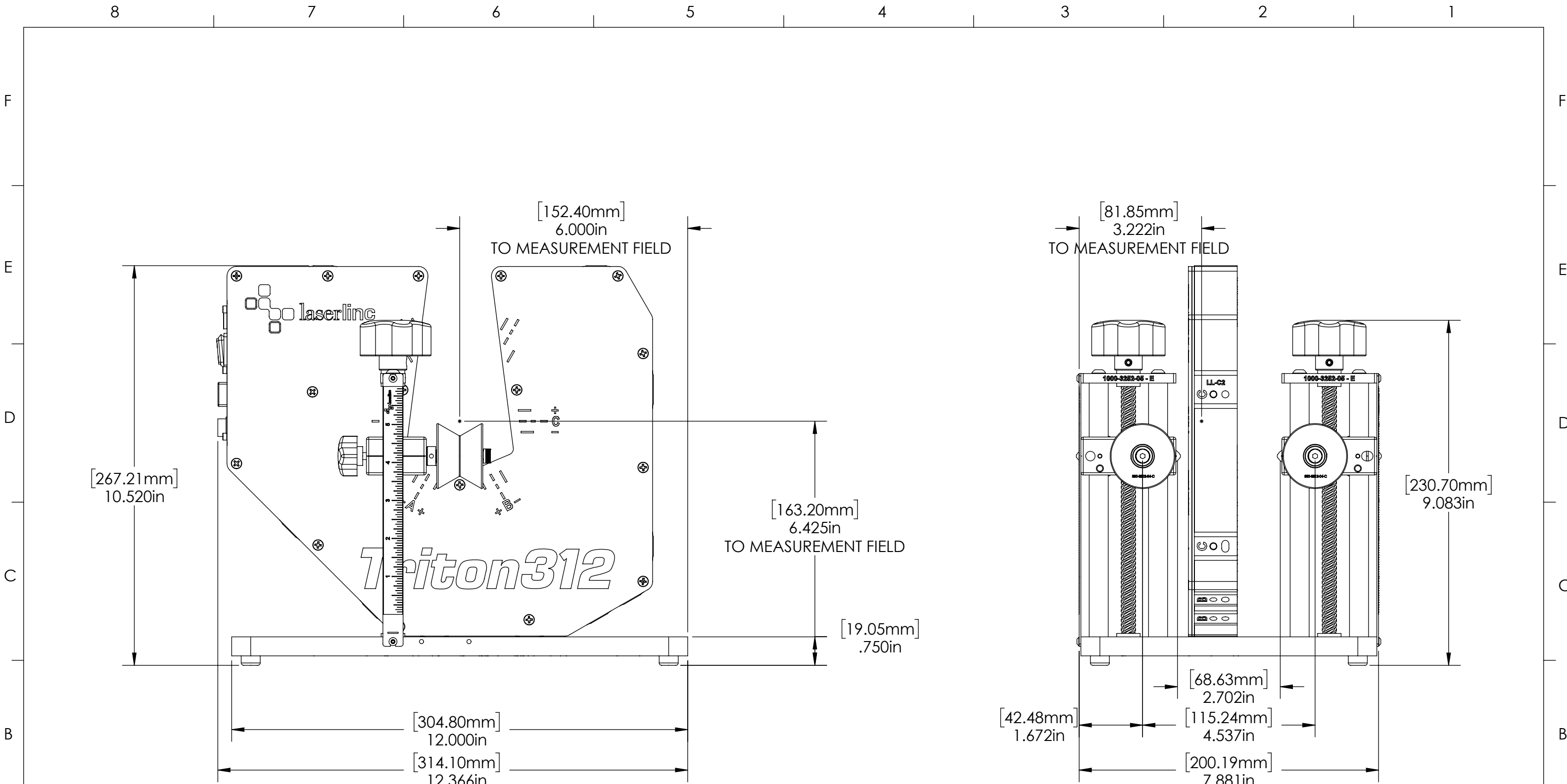

<b>GENERAL FINISH NOTE</b> <b>DE-BURR AND BREAK</b> <b>ALL SHARP EDGES</b> <b>BEFORE FINISH AND/OR SHIPPING</b>	UNLESS OTHERWISE SPECIFIED: DIMENSIONS ARE IN INCHES TOLERANCES: ANGLES ±.25 TWO PLACE DECIMAL ±0.010 THREE PLACE DECIMAL ±0.005 FOUR PLACE DECIMAL ±0.0005 UNMARKED FILLETS/CHAMFER .06 DE-BURR ALL PARTS	NAME DATE	 <b>LASERLINC, INC.</b> PHONE: 888-707-4892 INFO@LASERLINC.COM WWW.LASERLINC.COM
	INTERPRET GEOMETRIC TOLERANCING PER: ASME Y14.5	DRAWN BY: MWD 9/3/2021	
<b>PROPRIETARY AND CONFIDENTIAL</b> THE INFORMATION CONTAINED IN THIS DRAWING IS THE SOLE PROPERTY OF LASERLINC, INC. ANY REPRODUCTION IN PART OR AS A WHOLE WITHOUT THE WRITTEN PERMISSION OF LASERLINC, INC. IS PROHIBITED.	MATERIAL FINISH DO NOT SCALE DRAWING	63 RA SURFACE FINISH ALL FEATURES MUST MEET SPECIFICATION AFTER PLATING BEFORE POWDER-COAT IF PLATED OR POWDER-COATED <b>SEE FINISH</b>	SIZE <b>B</b> DWG. NO. 1000-0001-62 SCALE: 2:5
			REV <b>A</b> SHEET 4 OF 5