

8 7 6 5 4 3 2 1

F
E
D
C
B
A

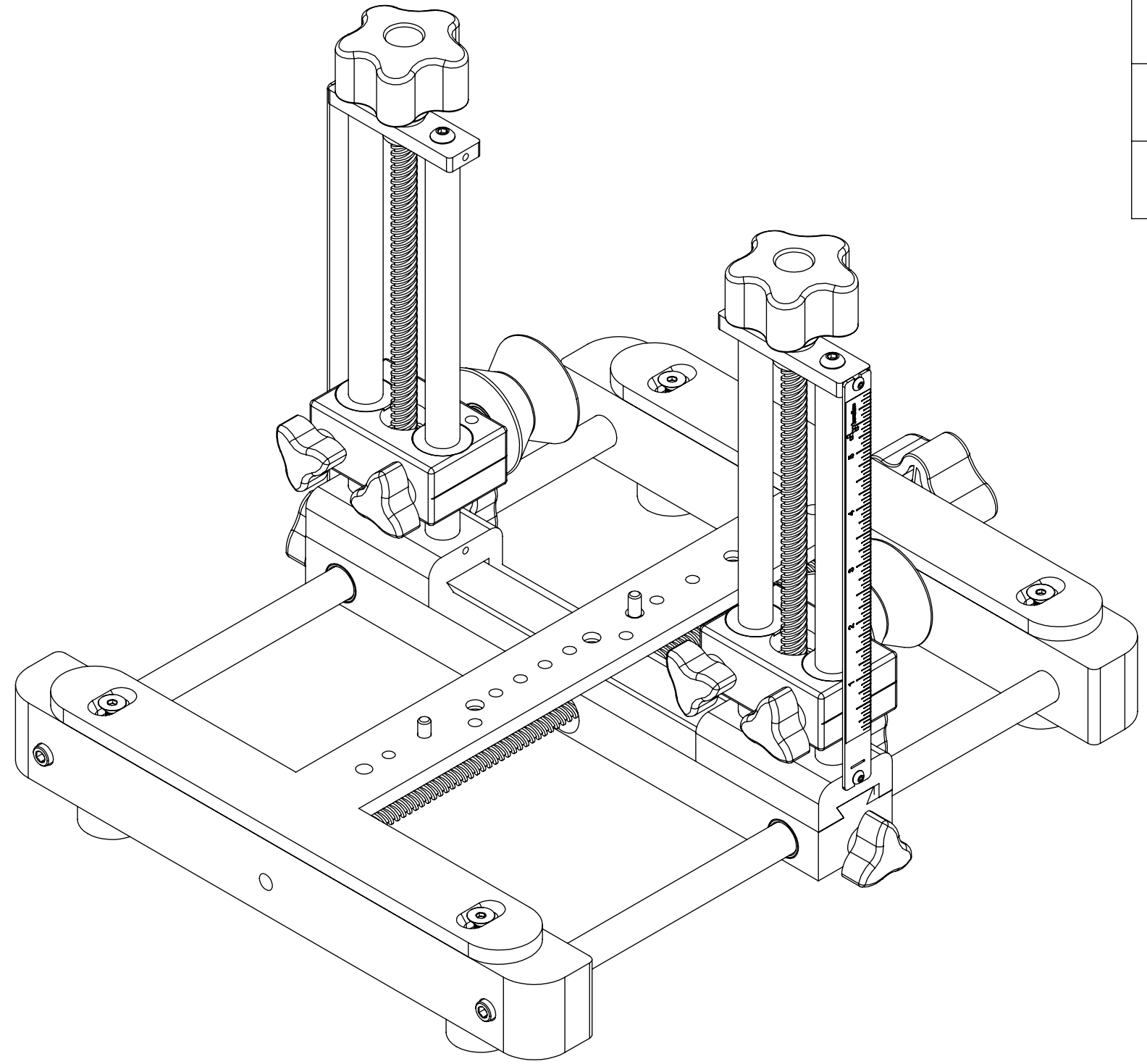

REVISIONS				
ZONE	REV.	DESCRIPTION	DATE	APPROVED
	A	CHECK-IN	3/26/2013	MAM

1000-0001-63 HORIZONTAL-VERTICAL ADJUST ROLLER GUIDE, 6IN OVERALL DIMENSIONS

INDEX

- (1) COVER PAGE
- (2) MOUNTED BOM

GENERAL FINISH NOTE DE-BURR AND BREAK ALL SHARP EDGES BEFORE FINISH AND/OR SHIPPING	UNLESS OTHERWISE SPECIFIED: DIMENSIONS ARE IN INCHES TOLERANCES: ANGLES ±.25° TWO PLACE DECIMAL ±0.010 THREE PLACE DECIMAL ±0.005 FOUR PLACE DECIMAL ±0.0005 UNMARKED FILLETS/CHAMFER .06 DE-BURR ALL PARTS	NAME MAM	DATE 3/26/2013	 LaserLinc, Inc. Phone: 888-707-4892 Info@laserlinc.com www.laserlinc.com
	PROPRIETARY AND CONFIDENTIAL THE INFORMATION CONTAINED IN THIS DRAWING IS THE SOLE PROPERTY OF LASERLINC, INC. ANY REPRODUCTION IN PART OR AS A WHOLE WITHOUT THE WRITTEN PERMISSION OF LASERLINC, INC. IS PROHIBITED.	INTERPRET GEOMETRIC TOLERANCING PER: ASME Y14.5 MATERIAL FINISH DO NOT SCALE DRAWING	DRAWN BY: MAM	
	63 RA SURFACE FINISH ALL FEATURES MUST MEET SPECIFICATION AFTER PLATING BEFORE POWDER-COAT IF PLATED OR POWDER-COATED SEE FINISH	SIZE B	DWG. NO. 1000-0001-63	REV A
		SCALE: 1:2	SHEET 1 OF 12	

8 7 6 5 4 3 2 1

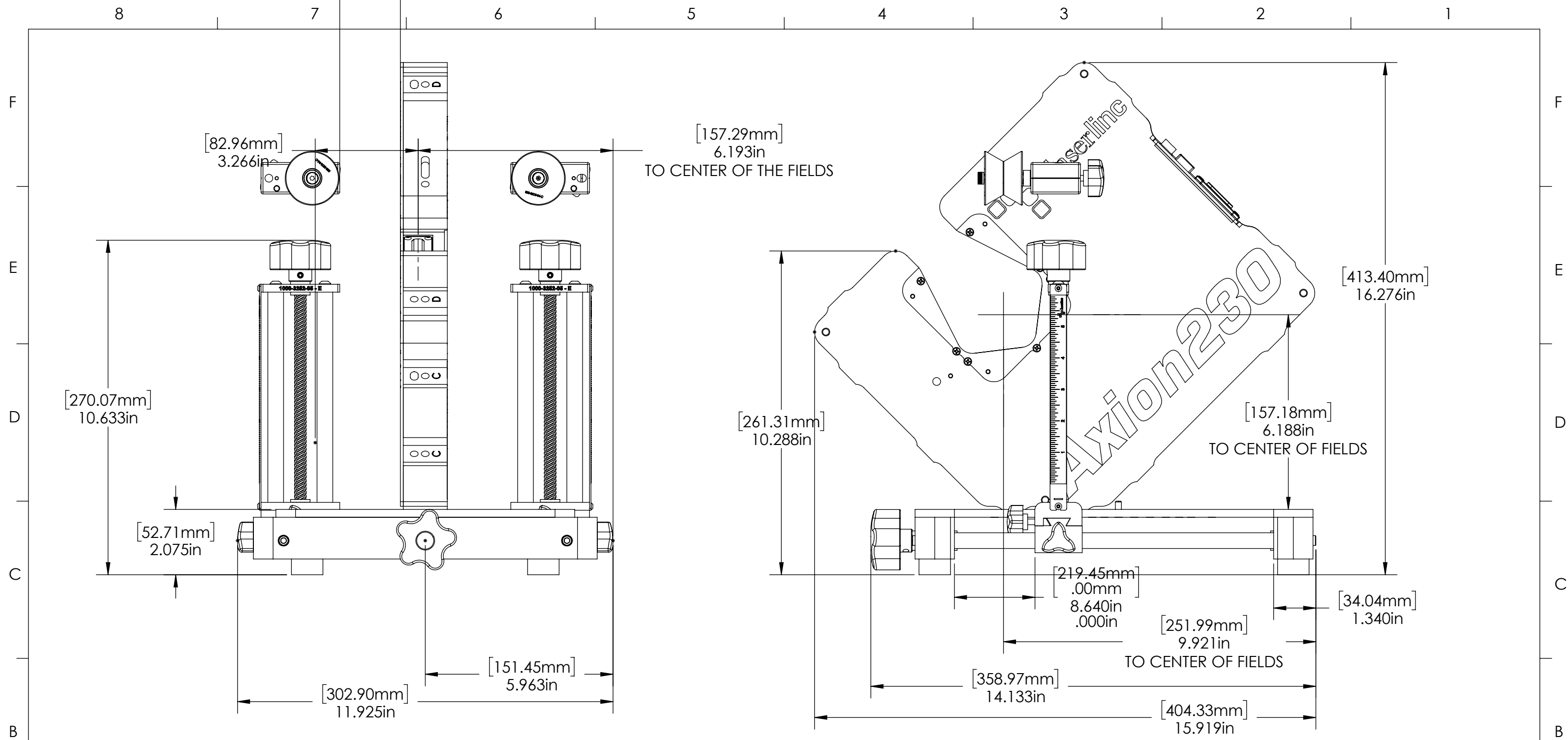

GENERAL FINISH NOTE DE-BURR AND BREAK ALL SHARP EDGES BEFORE FINISH AND/OR SHIPPING	UNLESS OTHERWISE SPECIFIED: DIMENSIONS ARE IN INCHES TOLERANCES: ANGLES ±.25° TWO PLACE DECIMAL ±0.010 THREE PLACE DECIMAL ±0.005 FOUR PLACE DECIMAL ±0.0005 UNMARKED FILLETS/CHAMFER .06 DE-BURR ALL PARTS	NAME: MAM DATE: 3/26/2013	 LASERLINC, INC. PHONE: 888-707-4892 INFO@LASERLINC.COM WWW.LASERLINC.COM
	PROPRIETARY AND CONFIDENTIAL THE INFORMATION CONTAINED IN THIS DRAWING IS THE SOLE PROPERTY OF LASERLINC, INC. ANY REPRODUCTION IN PART OR AS A WHOLE WITHOUT THE WRITTEN PERMISSION OF LASERLINC, INC. IS PROHIBITED.	INTERPRET GEOMETRIC TOLERANCING PER: ASME Y14.5 MATERIAL: FINISH: DO NOT SCALE DRAWING	
	63 RA SURFACE FINISH ALL FEATURES MUST MEET SPECIFICATION AFTER PLATING BEFORE POWDER-COAT IF PLATED OR POWDER-COATED SEE FINISH	SIZE: B DWG. NO.: 1000-0001-63 SCALE: 1:3	REV: A SHEET 2 OF 12

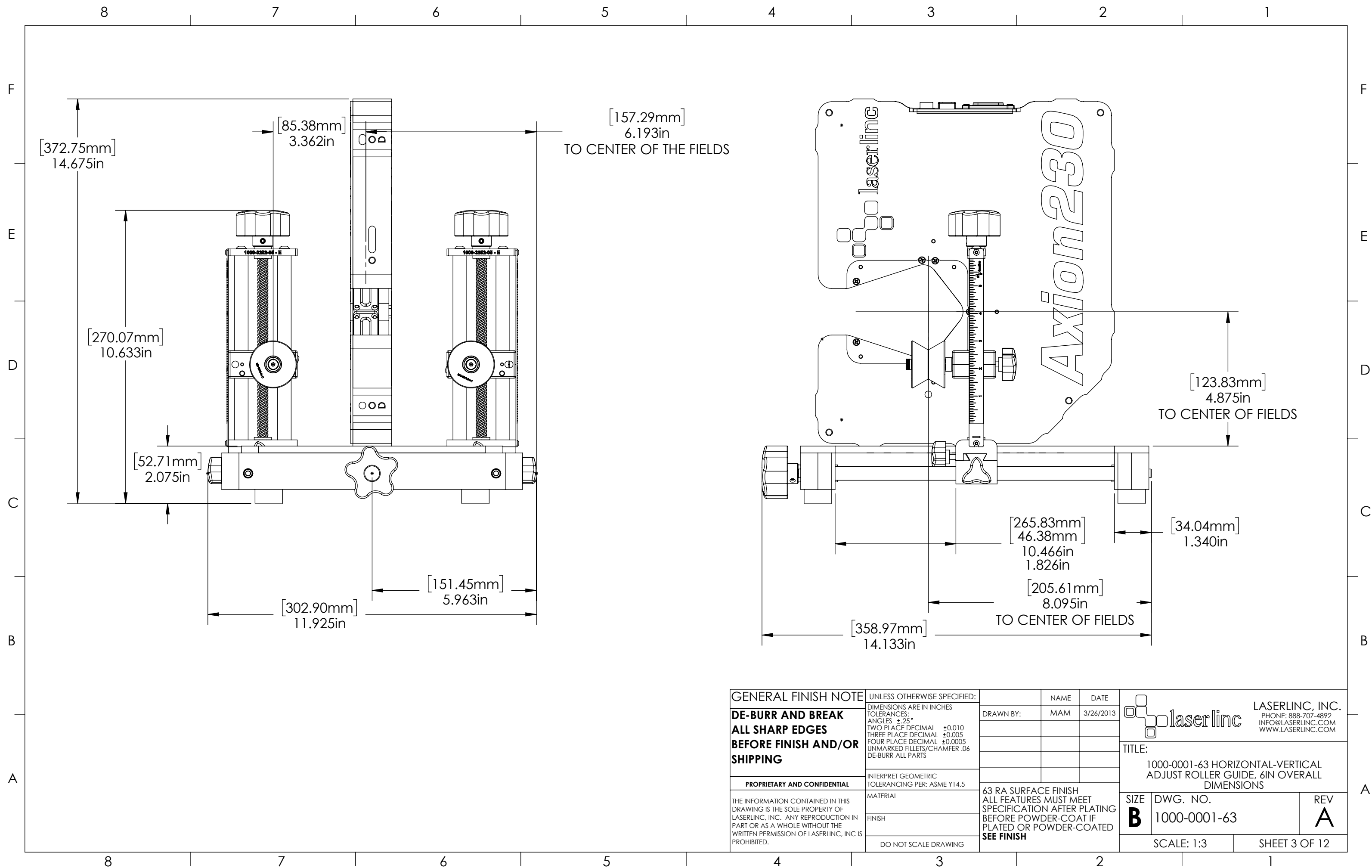

GENERAL FINISH NOTE DE-BURR AND BREAK ALL SHARP EDGES BEFORE FINISH AND/OR SHIPPING	UNLESS OTHERWISE SPECIFIED:	NAME	DATE	 LASERLINC, INC. PHONE: 888-707-4892 INFO@LASERLINC.COM WWW.LASERLINC.COM	
	DIMENSIONS ARE IN INCHES	DRAWN BY:	MAM		3/26/2013
	TOLERANCES:				
	ANGLES ±.25° TWO PLACE DECIMAL ±0.010 THREE PLACE DECIMAL ±0.005 FOUR PLACE DECIMAL ±0.0005 UNMARKED FILLETS/CHAMFER .06 DE-BURR ALL PARTS				
PROPRIETARY AND CONFIDENTIAL THE INFORMATION CONTAINED IN THIS DRAWING IS THE SOLE PROPERTY OF LASERLINC, INC. ANY REPRODUCTION IN PART OR AS A WHOLE WITHOUT THE WRITTEN PERMISSION OF LASERLINC, INC. IS PROHIBITED.	INTERPRET GEOMETRIC TOLERANCING PER: ASME Y14.5 MATERIAL FINISH DO NOT SCALE DRAWING	TITLE: 1000-0001-63 HORIZONTAL-VERTICAL ADJUST ROLLER GUIDE, 6IN OVERALL DIMENSIONS		SIZE B DWG. NO. 1000-0001-63 SCALE: 1:3	
				REV A SHEET 3 OF 12	