

8

7

6

5

4

3

2

1

REVISIONS				
ZONE	REV.	DESCRIPTION	DATE	APPROVED
	A	Check-in	12/15/2014	MAM

F

F

E

E

D

D

C

C

B

B

A

A

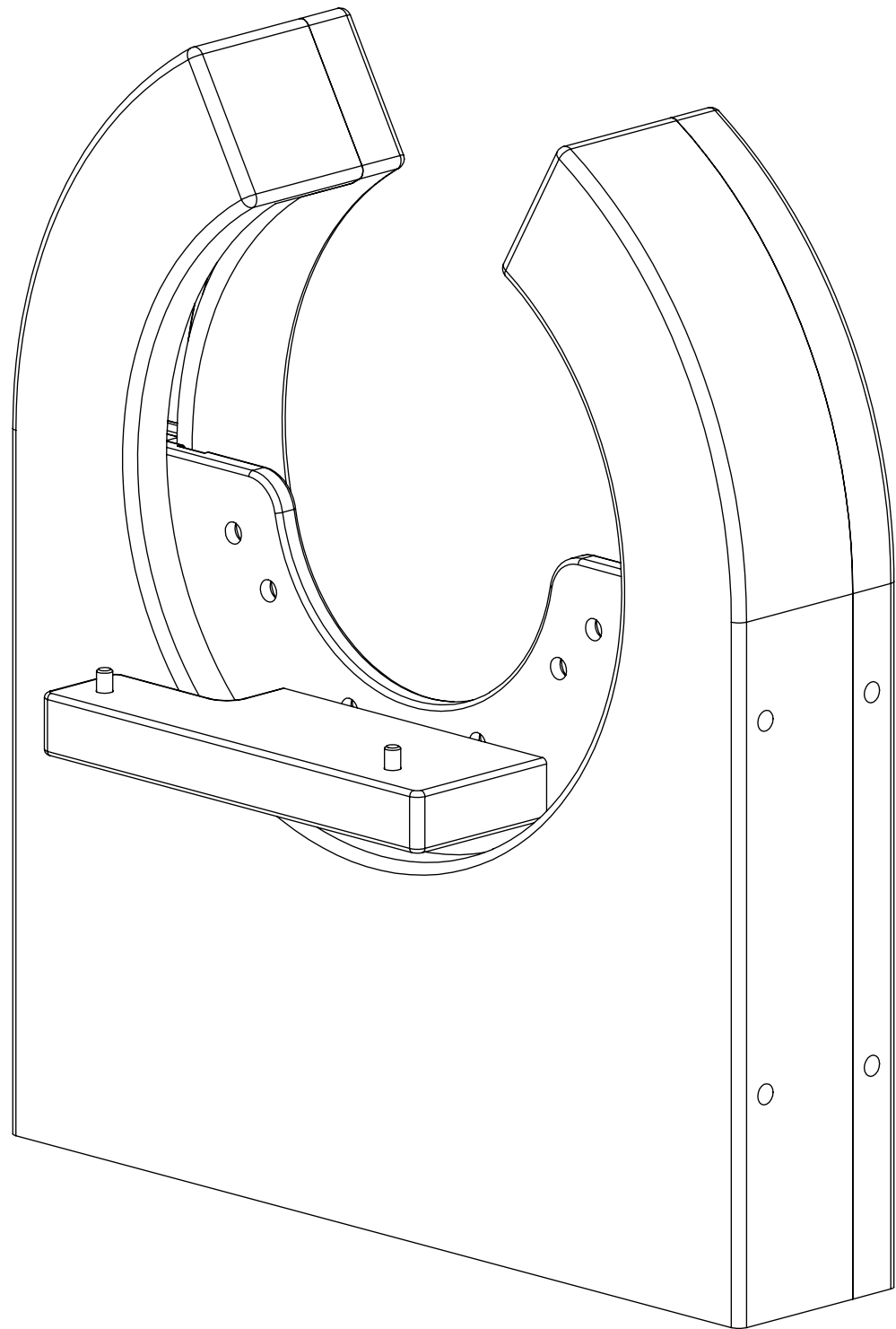

METRON-R, TLASER122- AXION222 MANUAL ROTATION SYSTEM OVERALLS

INDEX

- (1) COVER PAGE
- (2) FIXTURE DIMENSIONS
- (3) MOUNTED DIMENSIONS

GENERAL FINISH NOTE		UNLESS OTHERWISE SPECIFIED:		NAME	DATE	 LASERLINC, INC. PHONE: 888-707-4892 INFO@LASERLINC.COM WWW.LASERLINC.COM
DE-BURR AND BREAK ALL SHARP EDGES BEFORE FINISH AND/OR SHIPPING		DIMENSIONS ARE IN INCHES TOLERANCES: ANGLES ±.25° TWO PLACE DECIMAL ±0.010 THREE PLACE DECIMAL ±0.005 FOUR PLACE DECIMAL ±0.0005 UNMARKED FILLETS/CHAMFER .06 DE-BURR ALL PARTS		DRAWN BY:	EMM	
PROPRIETARY AND CONFIDENTIAL		INTERPRET GEOMETRIC TOLERANCING PER: ASME Y14.5		TITLE: 8103-0000-82 METRON-R, TLASER122- AXION222 MANUAL ROTATION SYSTEM OVERALLS		
THE INFORMATION CONTAINED IN THIS DRAWING IS THE SOLE PROPERTY OF LASERLINC, INC. ANY REPRODUCTION IN PART OR AS A WHOLE WITHOUT THE WRITTEN PERMISSION OF LASERLINC, INC. IS PROHIBITED.		MATERIAL		63 RA SURFACE FINISH ALL FEATURES MUST MEET SPECIFICATION AFTER PLATING BEFORE POWDER-COAT IF PLATED OR POWDER-COATED SEE FINISH		
DO NOT SCALE DRAWING		SIZE B		DWG. NO. 8103-0000-82		REV A
		SCALE: 1:2		SHEET 1 OF 4		

8

7

6

5

4

3

2

1

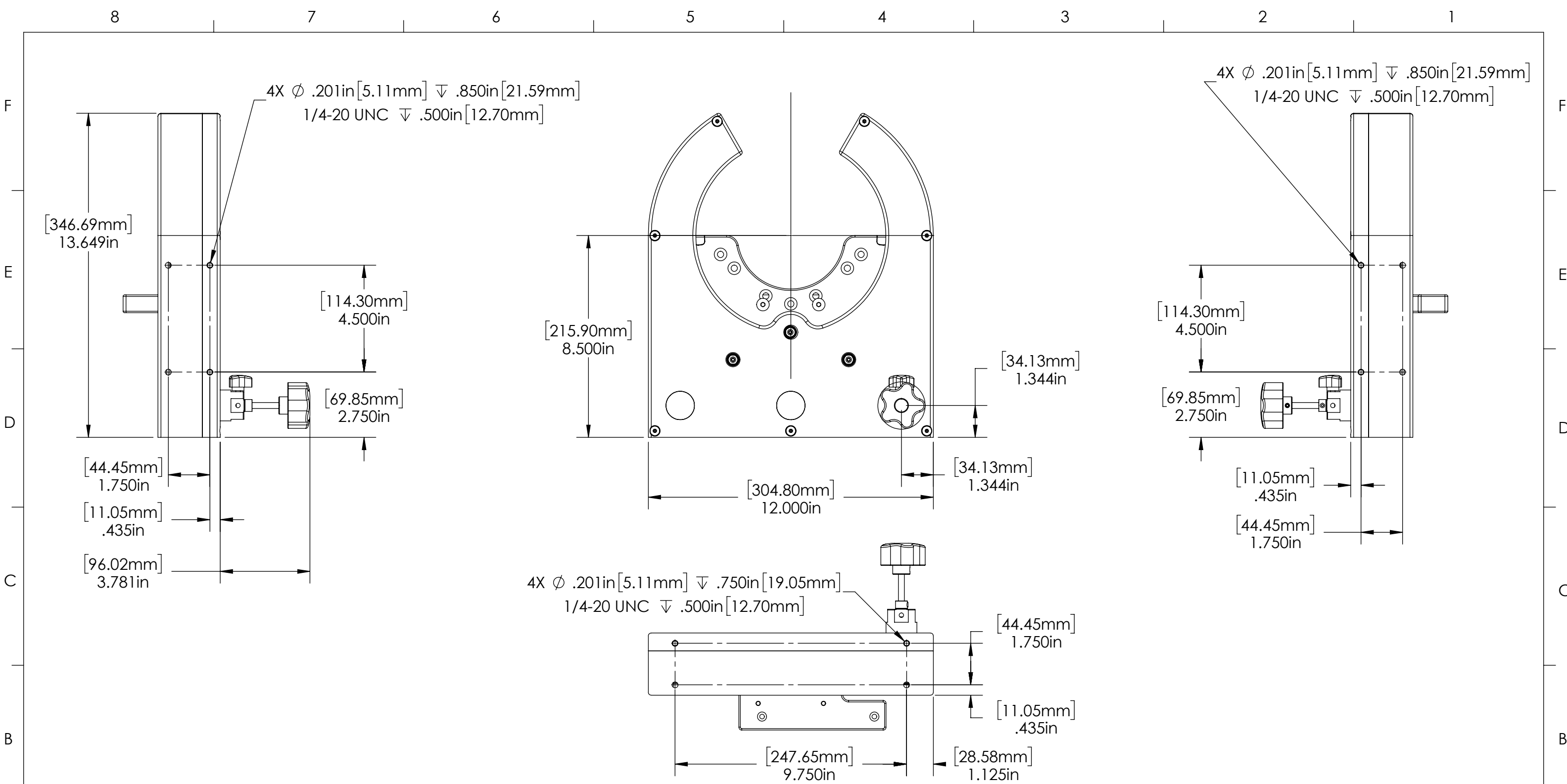

GENERAL FINISH NOTE DE-BURR AND BREAK ALL SHARP EDGES BEFORE FINISH AND/OR SHIPPING PROPRIETARY AND CONFIDENTIAL THE INFORMATION CONTAINED IN THIS DRAWING IS THE SOLE PROPERTY OF LASERLINC, INC. ANY REPRODUCTION IN PART OR AS A WHOLE WITHOUT THE WRITTEN PERMISSION OF LASERLINC, INC IS PROHIBITED.	UNLESS OTHERWISE SPECIFIED: DIMENSIONS ARE IN INCHES TOLERANCES: ANGLES ±.25° TWO PLACE DECIMAL ±0.010 THREE PLACE DECIMAL ±0.005 FOUR PLACE DECIMAL ±0.0005 UNMARKED FILLETS/CHAMFER .06 DE-BURR ALL PARTS	NAME DATE DRAWN BY: EMM 1/21/2021	 LASERLINC, INC. PHONE: 888-707-4892 INFO@LASERLINC.COM WWW.LASERLINC.COM	
	INTERPRET GEOMETRIC TOLERANCING PER: ASME Y14.5	TITLE: 8103-0000-82 METRON-R, TLASER122- AXION222 MANUAL ROTATION SYSTEM OVERALLS		
	MATERIAL FINISH DO NOT SCALE DRAWING	63 RA SURFACE FINISH ALL FEATURES MUST MEET SPECIFICATION AFTER PLATING BEFORE POWDER-COAT IF PLATED OR POWDER-COATED SEE FINISH	SIZE B DWG. NO. 8103-0000-82 SCALE: 1:4	REV A SHEET 2 OF 4

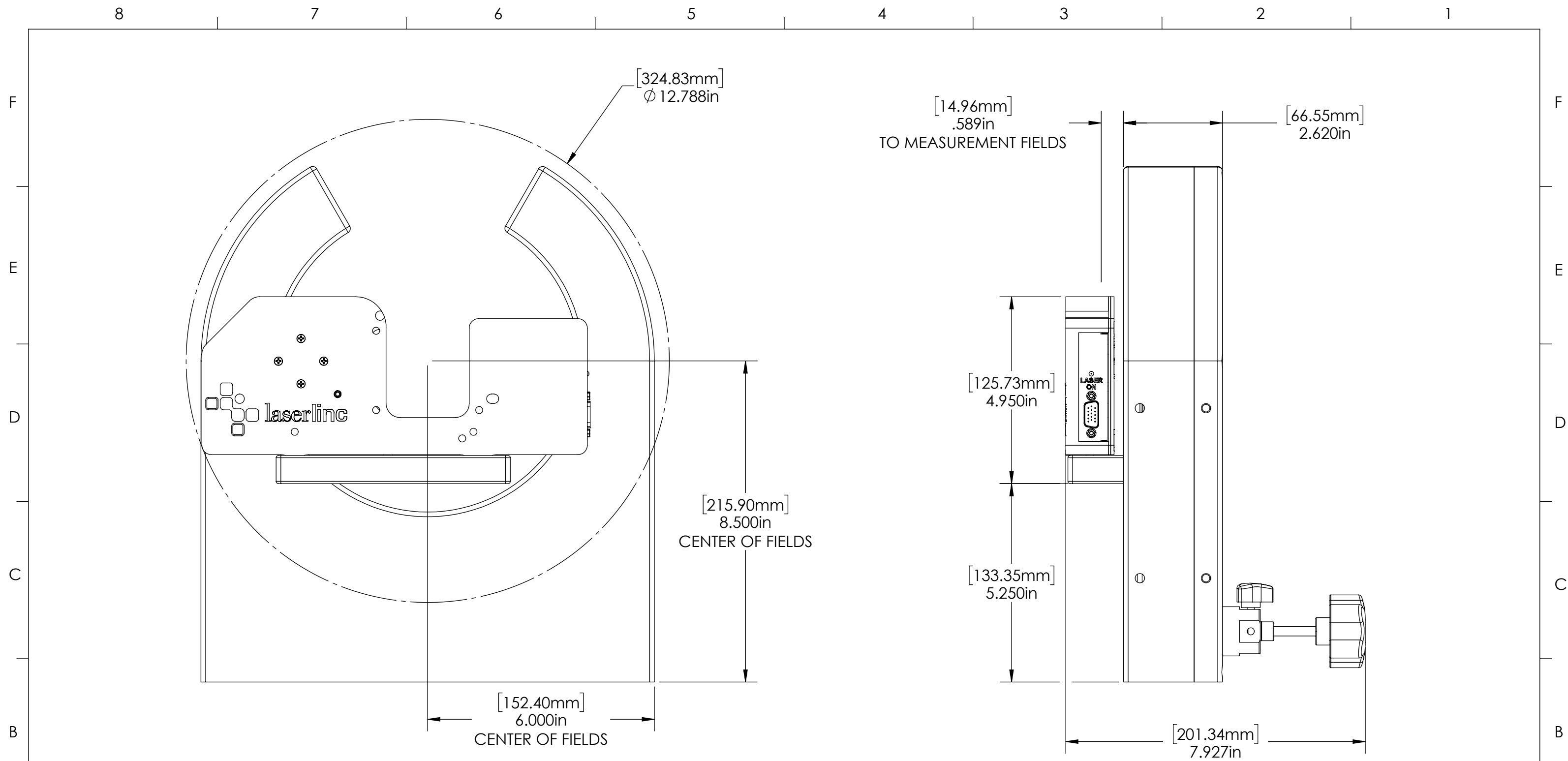

GENERAL FINISH NOTE DE-BURR AND BREAK ALL SHARP EDGES BEFORE FINISH AND/OR SHIPPING	UNLESS OTHERWISE SPECIFIED: DIMENSIONS ARE IN INCHES TOLERANCES: ANGLES ±.25° TWO PLACE DECIMAL ±0.010 THREE PLACE DECIMAL ±0.005 FOUR PLACE DECIMAL ±0.0005 UNMARKED FILLETS/CHAMFER .06 DE-BURR ALL PARTS	NAME DATE	 LASERLINC, INC. PHONE: 888-707-4892 INFO@LASERLINC.COM WWW.LASERLINC.COM	
	PROPRIETARY AND CONFIDENTIAL THE INFORMATION CONTAINED IN THIS DRAWING IS THE SOLE PROPERTY OF LASERLINC, INC. ANY REPRODUCTION IN PART OR AS A WHOLE WITHOUT THE WRITTEN PERMISSION OF LASERLINC, INC. IS PROHIBITED.	INTERPRET GEOMETRIC TOLERANCING PER: ASME Y14.5 MATERIAL FINISH DO NOT SCALE DRAWING		DRAWN BY: EMM 1/21/2021
		63 RA SURFACE FINISH ALL FEATURES MUST MEET SPECIFICATION AFTER PLATING BEFORE POWDER-COAT IF PLATED OR POWDER-COATED SEE FINISH		
		SIZE B	DWG. NO. 8103-0000-82	REV A
		SCALE: 2:5		SHEET 3 OF 4