

8

7

6

5

4

3

2

1

REVISIONS

ZONE	REV.	DESCRIPTION	DATE	APPROVED
	A	Check-In	3/1/2013	MAM

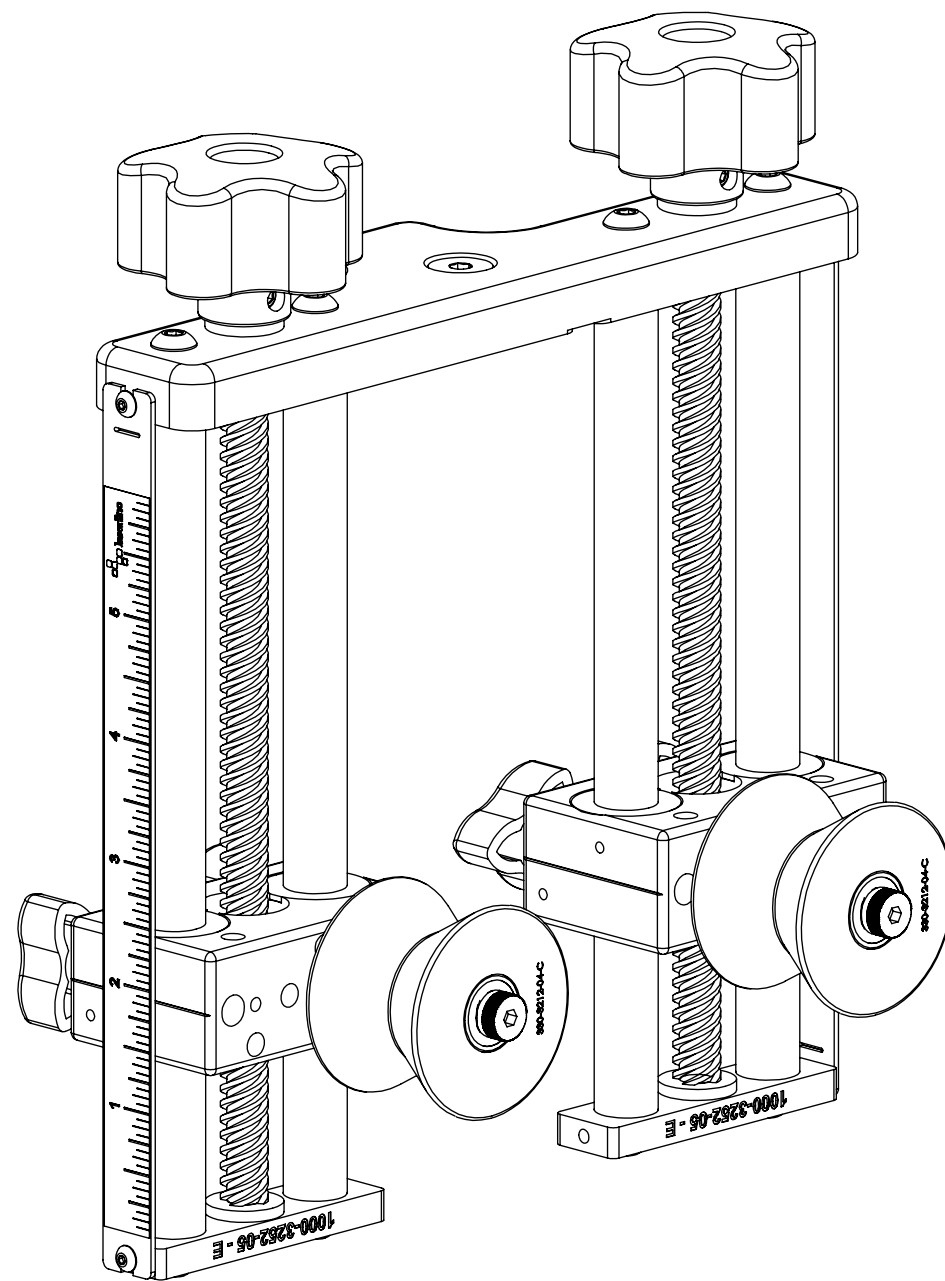

X30 BODY MOUNT ROLLER GUIDE, 7IN

INDEX

- (1) COVER PAGE
- (2) BOM TABLE
- (3) ASSEMBLE SLIDE
- (4) ASSEMBLE RODS AND AMCE SCREW
- (5) ASSEMBLE BOTTOM PLATE
- (6) ASSEMBLE RULER
- (7) QUALITY CHECK
- (8) MOUNT AXION 230
- (9) MOUNT TRITON 312
- (10) MOUNT TRITON 330
- (11) FIXTURE DIMENSION OVERALLS
- (12) 230 MOUNTED DIMENSION OVERALL
- (13) 312 MOUNTED DIMENSION OVERALL
- (14) 330 MOUNTED DIMENSION OVERALL

GENERAL FINISH NOTE	UNLESS OTHERWISE SPECIFIED:	NAME	DATE	 LASERLINC, INC. PHONE: 888-707-4892 INFO@LASERLINC.COM WWW.LASERLINC.COM
DE-BURR AND BREAK ALL SHARP EDGES BEFORE FINISH AND/OR SHIPPING	DIMENSIONS ARE IN INCHES TOLERANCES: ANGLES ±.25° TWO PLACE DECIMAL ±0.010 THREE PLACE DECIMAL ±0.005 FOUR PLACE DECIMAL ±0.0005 UNMARKED FILLETS/CHAMFER .06 DE-BURR ALL PARTS	DRAWN BY: EMM	08/27/2021	
PROPRIETARY AND CONFIDENTIAL	INTERPRET GEOMETRIC TOLERANCING PER: ASME Y14.5			TITLE: X30 BODY MOUNT ROLLER GUIDE, 7IN
THE INFORMATION CONTAINED IN THIS DRAWING IS THE SOLE PROPERTY OF LASERLINC, INC. ANY REPRODUCTION IN PART OR AS A WHOLE WITHOUT THE WRITTEN PERMISSION OF LASERLINC, INC. IS PROHIBITED.	MATERIAL	63 RA SURFACE FINISH ALL FEATURES MUST MEET SPECIFICATION AFTER PLATING BEFORE POWDER-COAT IF PLATED OR POWDER-COATED SEE FINISH		SIZE B
	FINISH			DWG. NO. 1000-0000-61
	DO NOT SCALE DRAWING			REV A
		SCALE: 2:3		SHEET 1 OF 14

8

7

6

5

4

3

2

1

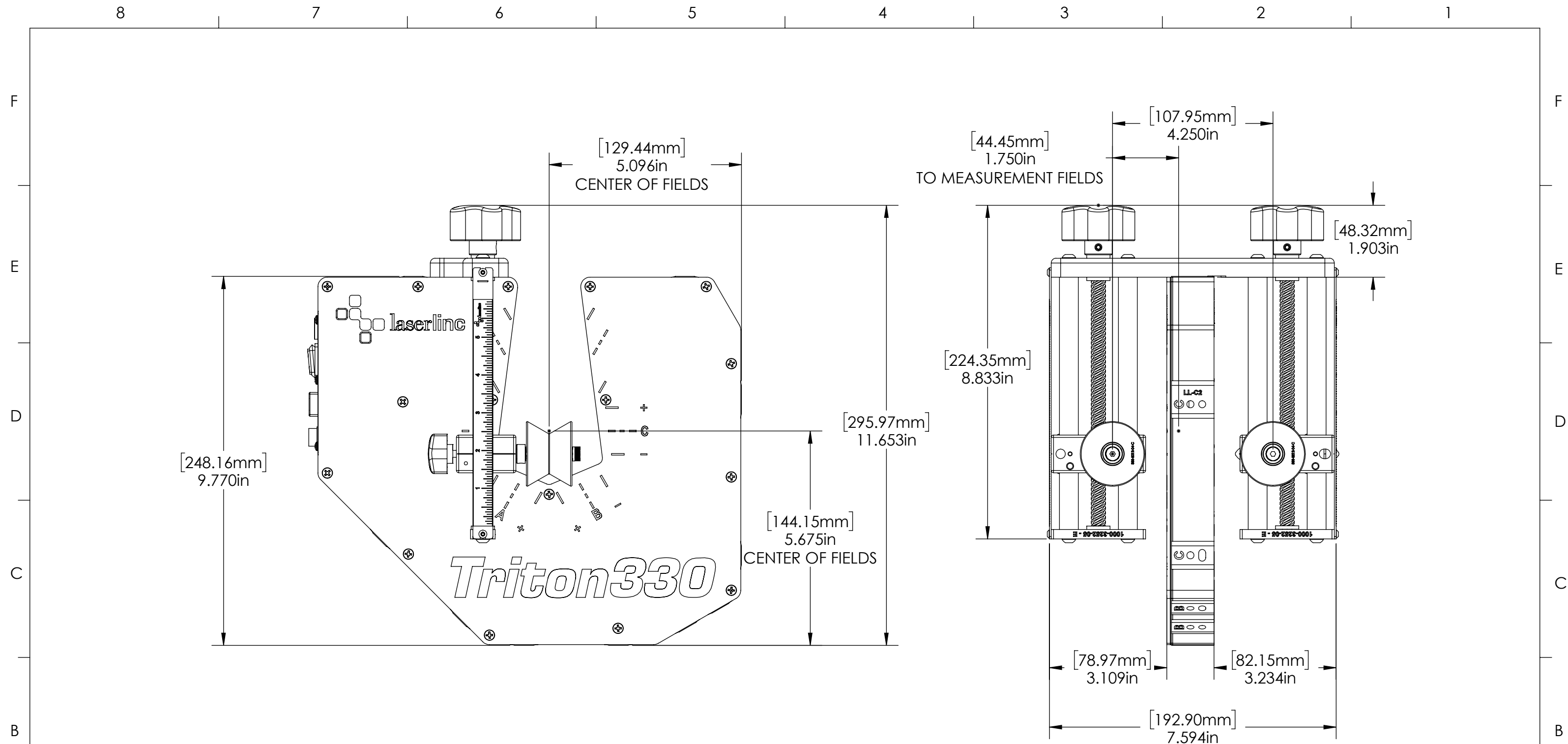

GENERAL FINISH NOTE		UNLESS OTHERWISE SPECIFIED:		NAME	DATE
DE-BURR AND BREAK ALL SHARP EDGES BEFORE FINISH AND/OR SHIPPING		DIMENSIONS ARE IN INCHES TOLERANCES: ANGLES ±.25° TWO PLACE DECIMAL ±0.010 THREE PLACE DECIMAL ±0.005 FOUR PLACE DECIMAL ±0.0005 UNMARKED FILLETS/CHAMFER .06 DE-BURR ALL PARTS		DRAWN BY:	EMM 08/27/2021
PROPRIETARY AND CONFIDENTIAL		INTERPRET GEOMETRIC TOLERANCING PER: ASME Y14.5			
THE INFORMATION CONTAINED IN THIS DRAWING IS THE SOLE PROPERTY OF LASERLINC, INC. ANY REPRODUCTION IN PART OR AS A WHOLE WITHOUT THE WRITTEN PERMISSION OF LASERLINC, INC. IS PROHIBITED.		MATERIAL		63 RA SURFACE FINISH ALL FEATURES MUST MEET SPECIFICATION AFTER PLATING BEFORE POWDER-COAT IF PLATED OR POWDER-COATED SEE FINISH	
		FINISH		TITLE: X30 BODY MOUNT ROLLER GUIDE, 7IN	
		DO NOT SCALE DRAWING		SIZE B	DWG. NO. 1000-0000-61
				SCALE: 2:5	REV A
				SHEET 14 OF 14	

LASERLINC, INC.
 PHONE: 888-707-4892
 INFO@LASERLINC.COM
 WWW.LASERLINC.COM