

8 7 6 5 4 3 2 1

REVISIONS				
ZONE	REV.	DESCRIPTION	DATE	APPROVED
	A	Check-In	6/27/2014	MAM

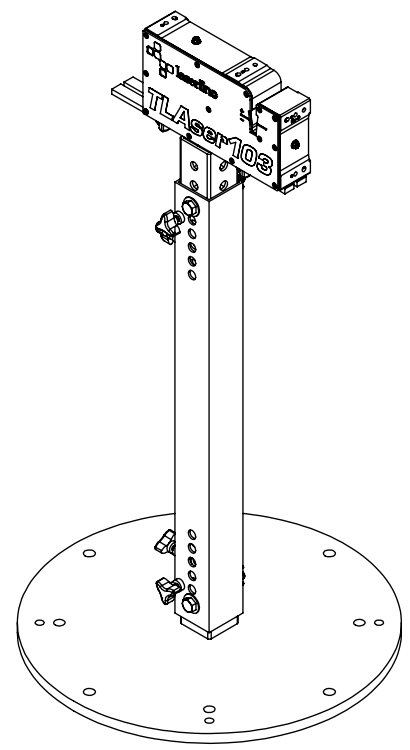

Stand for TLaser103 Overall Dimensions

INDEX

- (1) Cover Page
- (2) Fixture Dimensions
- (3) Mounted Dimensions

UNLESS OTHERWISE SPECIFIED:		NAME	DATE	 LaserLinc, Inc. Phone: 888-707-4892 Info@laserlinc.com www.laserlinc.com
DIMENSIONS ARE IN INCHES TOLERANCES: ANGULAR: MACH ± BEND ± TWO PLACE DECIMAL ±0.010 THREE PLACE DECIMAL ±0.005 FOUR PLACE DECIMAL ±0.0005 ANGLES ±.25° UNMARKED FILLETS/ROUNDS R.0625 DE-BURR ALL PARTS		DRAWN BY:	MAM	
INTERPRET GEOMETRIC TOLERANCING PER:		63 RA SURFACE FINISH ALL FEATURES MUST MEET SPECIFICATION AFTER PLATING BEFORE POWDER-COAT IF PLATED OR POWDER-COATED SEE FINISH MACHINE ALL SURFACES		
PROPRIETARY AND CONFIDENTIAL THE INFORMATION CONTAINED IN THIS DRAWING IS THE SOLE PROPERTY OF LASERLINC, INC. ANY REPRODUCTION IN PART OR AS A WHOLE WITHOUT THE WRITTEN PERMISSION OF LASERLINC, INC IS PROHIBITED.		MATERIAL		
DO NOT SCALE DRAWING		FINISH		
		TITLE: 00103-28 Stand for TLaser103 Overall Dimensions		SIZE B
		DWG. NO. 00103-28		REV A
		SCALE: 1:8		SHEET 1 OF 3

8 7 6 5 4 3 2 1

D
C
B
A

D
C
B
A

8 7 6 5 4 3 2 1

D
C
B
A

D
C
B
A

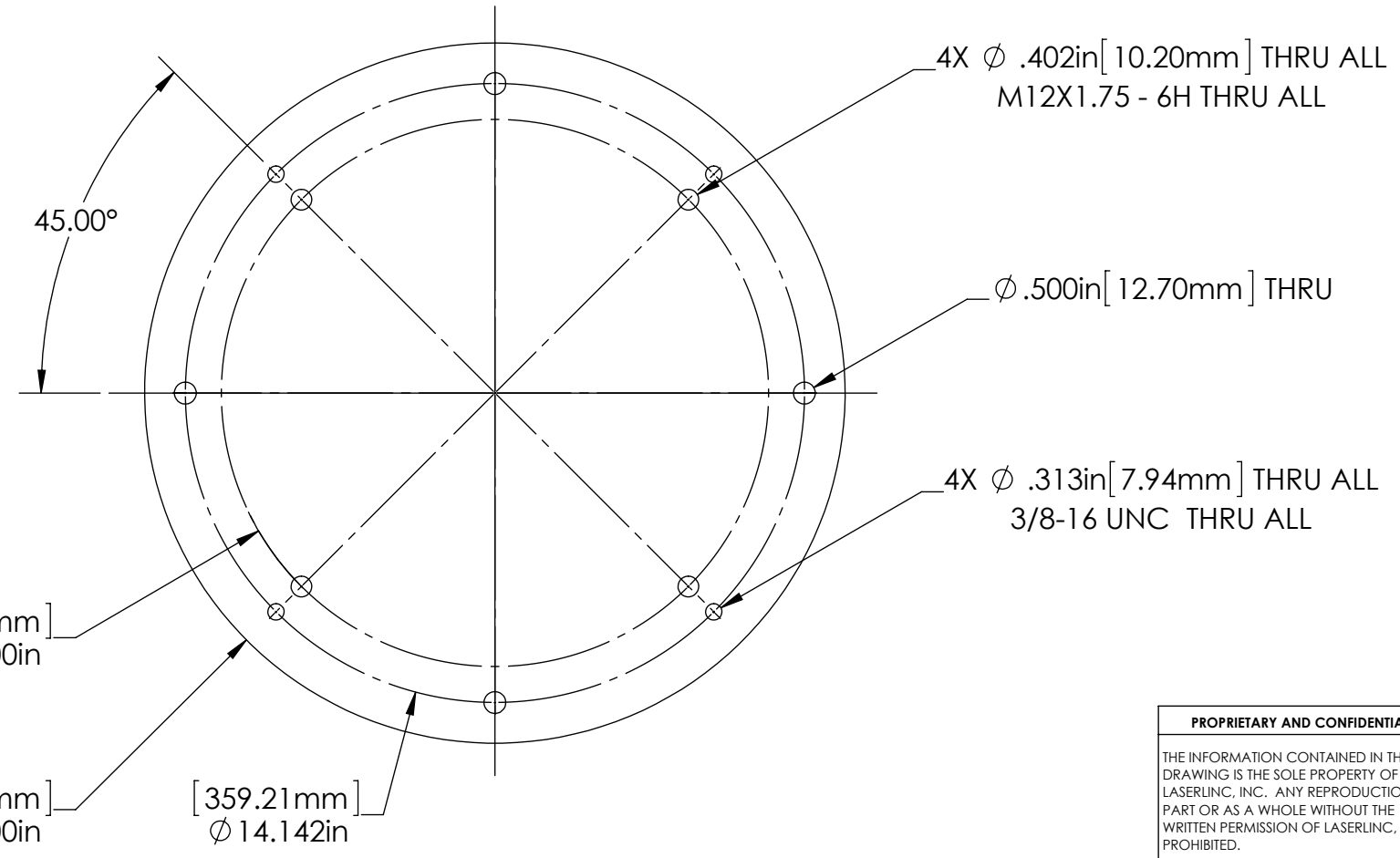
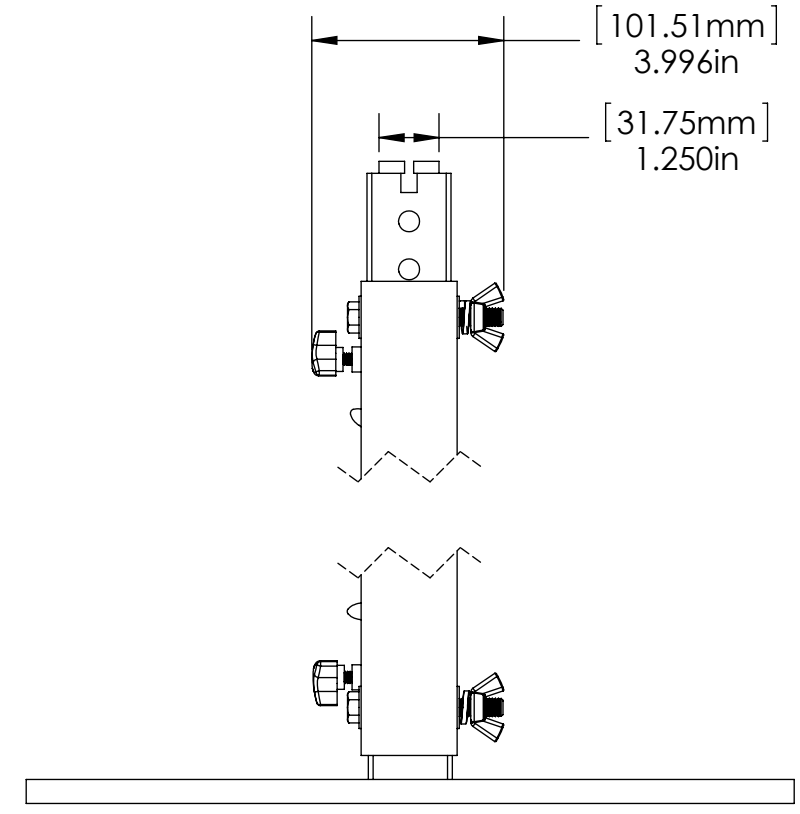
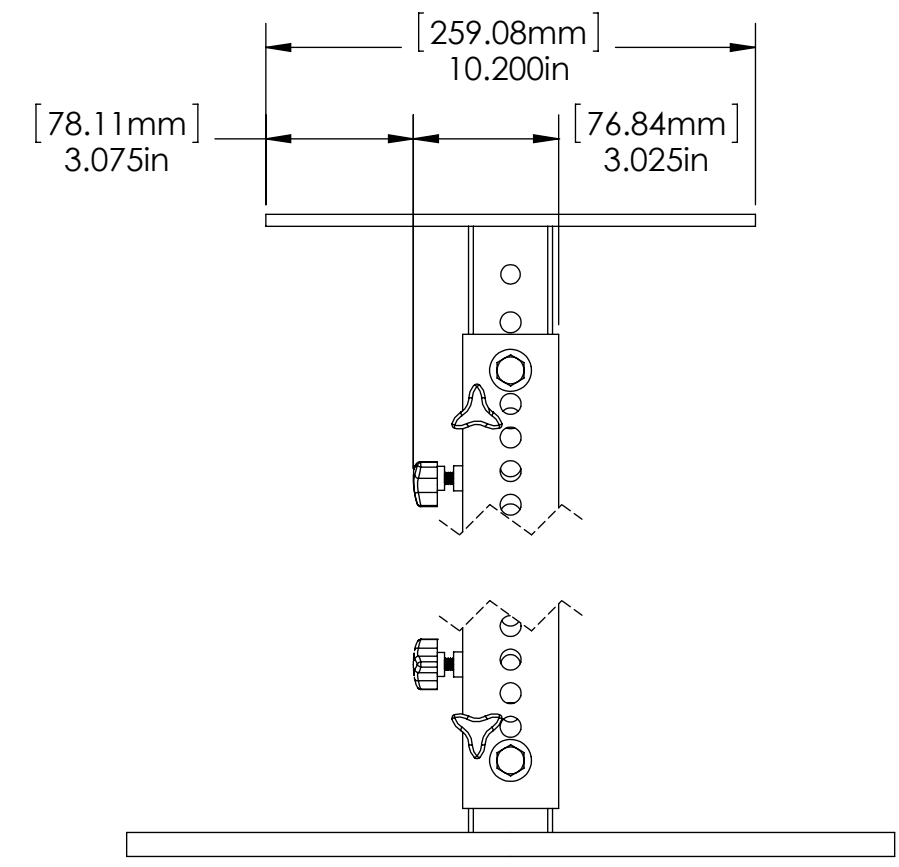

UNLESS OTHERWISE SPECIFIED:		NAME	DATE
DIMENSIONS ARE IN INCHES		DRAWN BY:	MAM 9/27/2014
TOLERANCES:			
ANGULAR: MACH ± BEND ±			
TWO PLACE DECIMAL ±0.010			
THREE PLACE DECIMAL ±0.005			
FOUR PLACE DECIMAL ±0.0005			
ANGLES ±.25°			
UNMARKED FILLETS/ROUNDS R.0625			
DE-BURR ALL PARTS			
INTERPRET GEOMETRIC TOLERANCING PER:			
MATERIAL		63 RA SURFACE FINISH	
FINISH		ALL FEATURES MUST MEET SPECIFICATION AFTER PLATING BEFORE POWDER-COAT IF PLATED OR POWDER-COATED	
DO NOT SCALE DRAWING		SEE FINISH MACHINE ALL SURFACES	

laserlinc LaserLinc, Inc.
Phone: 888-707-4892
Info@laserlinc.com
www.laserlinc.com

TITLE:
00103-28 Stand for TLAser103 Overall Dimensions

PROPRIETARY AND CONFIDENTIAL

THE INFORMATION CONTAINED IN THIS DRAWING IS THE SOLE PROPERTY OF LASERLINC, INC. ANY REPRODUCTION IN PART OR AS A WHOLE WITHOUT THE WRITTEN PERMISSION OF LASERLINC, INC IS PROHIBITED.

SIZE B	DWG. NO. 00103-28	REV A
SCALE: 1:4		SHEET 2 OF 3

8 7 6 5 4 3 2 1

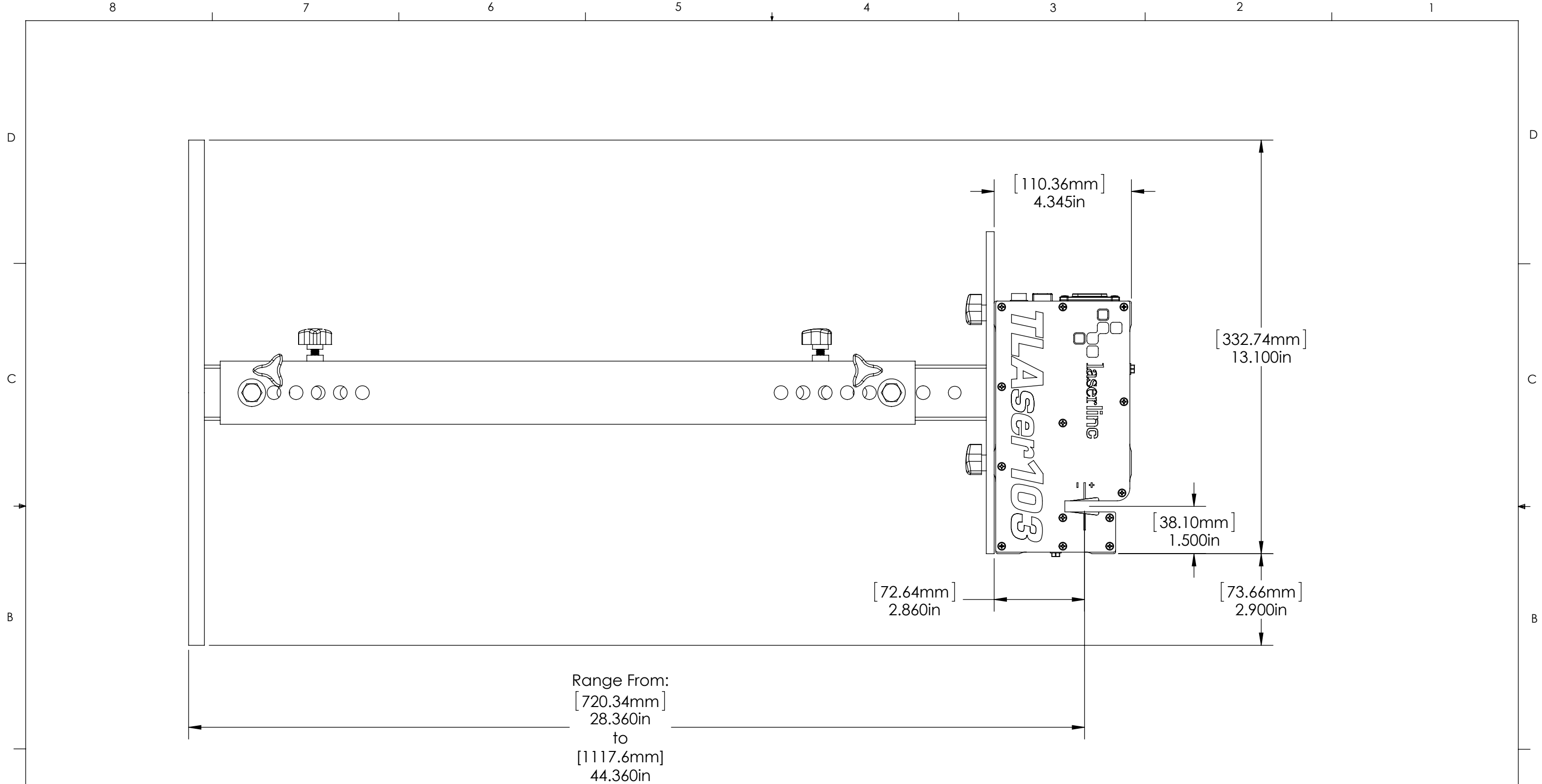

UNLESS OTHERWISE SPECIFIED:
 DIMENSIONS ARE IN INCHES
 TOLERANCES:
 ANGULAR: MACH ± BEND ±
 TWO PLACE DECIMAL ±0.010
 THREE PLACE DECIMAL ±0.005
 FOUR PLACE DECIMAL ±0.0005
 ANGLES ±.25°
 UNMARKED FILLETS/ROUNDS R.0625
 DE-BURR ALL PARTS

NAME	DATE
DRAWN BY: MAM	9/27/2014

laserline LaserLinc, Inc.
 Phone: 888-707-4892
 Info@laserline.com
 www.laserline.com

TITLE:
 00103-28 Stand for TLaser103 Overall Dimensions

PROPRIETARY AND CONFIDENTIAL
 THE INFORMATION CONTAINED IN THIS DRAWING IS THE SOLE PROPERTY OF LASERLINC, INC. ANY REPRODUCTION IN PART OR AS A WHOLE WITHOUT THE WRITTEN PERMISSION OF LASERLINC, INC IS PROHIBITED.

INTERPRET GEOMETRIC TOLERANCING PER:
 MATERIAL
 FINISH
 DO NOT SCALE DRAWING

63 RA SURFACE FINISH
 ALL FEATURES MUST MEET SPECIFICATION AFTER PLATING BEFORE POWDER-COAT IF PLATED OR POWDER-COATED
SEE FINISH MACHINE ALL SURFACES

SIZE	DWG. NO.	REV
B	00103-28	A
SCALE: 1:3		SHEET 3 OF 3