

8

7

6

5

4

3

2

1

| REVISIONS | | | | |
|-----------|------|----------------------|------------|----------|
| ZONE | REV. | DESCRIPTION | DATE | APPROVED |
| | A | CHECK-IN | 10/27/2010 | DRP |
| | B | ADDED MOUNTING PLATE | 5/10/2011 | DRP |

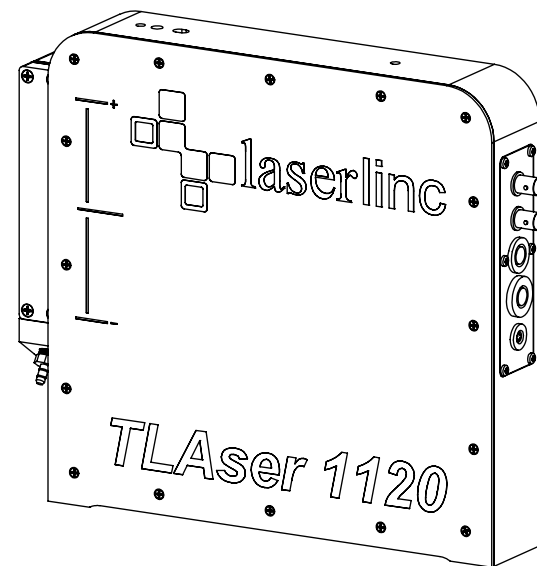
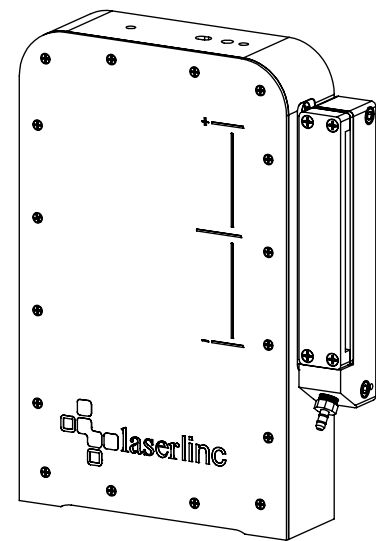

TLASER1120 AIR PURGE FIXTURE OVERALLS

INDEX

- (1) COVER PAGE
- (2) DIMENSIONS

| | | | | | | |
|---|--|---|--|---|------|---|
| GENERAL FINISH NOTE | | UNLESS OTHERWISE SPECIFIED: | | NAME | DATE |  LaserLinc, Inc. Phone: 888-707-4892 info@laserlinc.com www.laserlinc.com |
| DE-BURR AND BREAK ALL SHARP EDGES BEFORE FINISH AND/OR SHIPPING | | DIMENSIONS ARE IN INCHES TOLERANCES: ANGLES ±.25 TWO PLACE DECIMAL ±0.010 THREE PLACE DECIMAL ±0.005 FOUR PLACE DECIMAL ±0.0005 UNMARKED FILLETS/CHAMFER .06 DE-BURR ALL PARTS | | DRAWN BY: | EMM | |
| PROPRIETARY AND CONFIDENTIAL THE INFORMATION CONTAINED IN THIS DRAWING IS THE SOLE PROPERTY OF LASERLINC, INC. ANY REPRODUCTION IN PART OR AS A WHOLE WITHOUT THE WRITTEN PERMISSION OF LASERLINC, INC. IS PROHIBITED. | | INTERPRET GEOMETRIC TOLERANCING PER: ASME Y14.5 | | 63 RA SURFACE FINISH ALL FEATURES MUST MEET SPECIFICATION AFTER PLATING BEFORE POWDER-COAT IF PLATED OR POWDER-COATED SEE FINISH | | TITLE: 1120-0000-30 TLASER1120 Air Purge Fixture Overalls |
| | | MATERIAL | | SIZE B | | DWG. NO. 1120-0000-30 |
| | | FINISH | | | | REV B |
| | | DO NOT SCALE DRAWING | | SCALE: 1:4 | | SHEET 1 OF 2 |

8

7

6

5

4

3

2

1

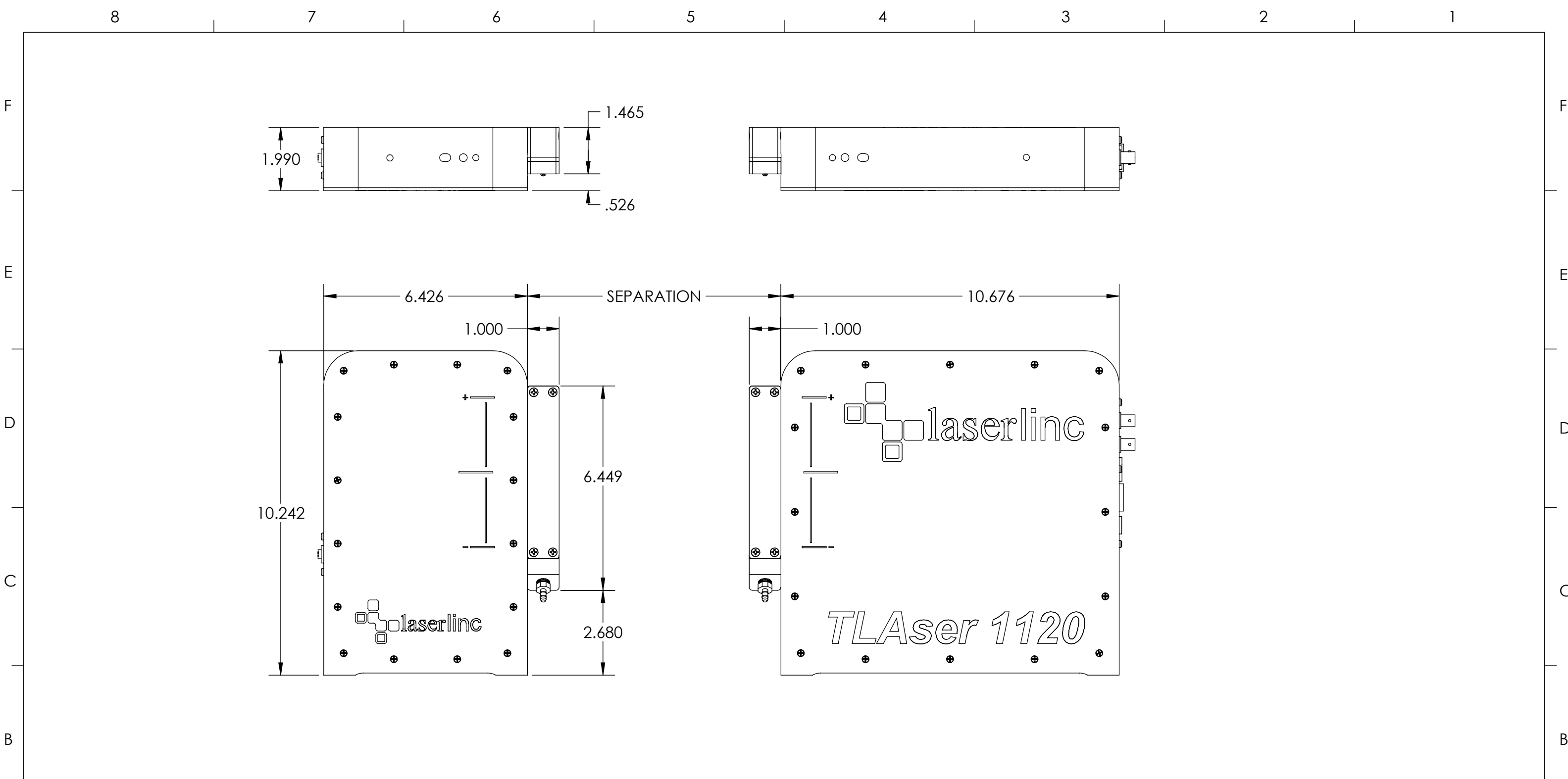

| | | | | | | |
|--|--|---|--|--|--------------------------|-----------------|
| GENERAL FINISH NOTE DE-BURR AND BREAK ALL SHARP EDGES BEFORE FINISH AND/OR SHIPPING PROPRIETARY AND CONFIDENTIAL THE INFORMATION CONTAINED IN THIS DRAWING IS THE SOLE PROPERTY OF LASERLINC, INC. ANY REPRODUCTION IN PART OR AS A WHOLE WITHOUT THE WRITTEN PERMISSION OF LASERLINC, INC. IS PROHIBITED. | UNLESS OTHERWISE SPECIFIED: DIMENSIONS ARE IN INCHES TOLERANCES: ANGLES ±.25 TWO PLACE DECIMAL ±0.010 THREE PLACE DECIMAL ±0.005 FOUR PLACE DECIMAL ±0.0005 UNMARKED FILLETS/CHAMFER .06 DE-BURR ALL PARTS | NAME DATE |  LaserLinc, Inc. Phone: 888-707-4892 Info@laserlinc.com www.laserlinc.com | | | |
| | INTERPRET GEOMETRIC TOLERANCING PER: ASME Y14.5 | DRAWN BY: EMM 11/17/2020 | | TITLE: 1120-0000-30 TLAser1 120 Air Purge Fixture Overalls | | |
| | MATERIAL FINISH DO NOT SCALE DRAWING | 63 RA SURFACE FINISH ALL FEATURES MUST MEET SPECIFICATION AFTER PLATING BEFORE POWDER-COAT IF PLATED OR POWDER-COATED SEE FINISH | | SIZE B | DWG. NO. 1120-0000-30 | REV B |
| | SCALE: 1:3 | | | SHEET 2 OF 2 | | |