

8

7

6

5

4

3

2

1

F

E

D

C

B

A

F

E

D

C

B

A

REVISIONS				
ZONE	REV.	DESCRIPTION	DATE	APPROVED
	A	Check-In	8/12/2015	MAM

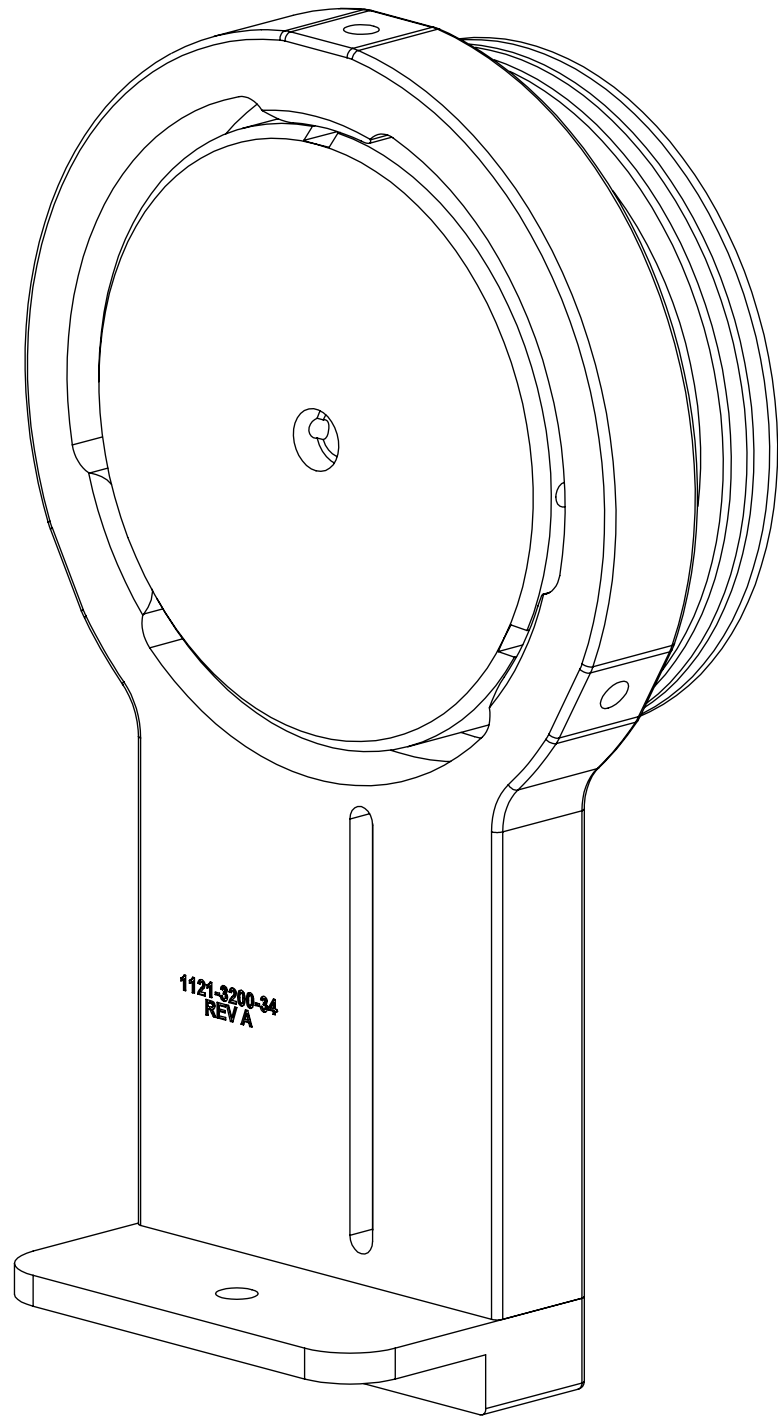

CALIBRATION FIXTURE FOR TLASER 1120 MICROMETER OVERALL DIMENSIONS

INDEX

- (1) COVER PAGE
- (2) FIXTURE DIMENSIONS
- (3) MOUNTED DIMENSIONS

GENERAL FINISH NOTE		UNLESS OTHERWISE SPECIFIED:		NAME	DATE	 LaserLinc, Inc. Phone: 888-707-4892 Info@laserlinc.com www.laserlinc.com
DE-BURR AND BREAK ALL SHARP EDGES BEFORE FINISH AND/OR SHIPPING		DIMENSIONS ARE IN INCHES TOLERANCES: ANGULAR: MACH ± BEND ± TWO PLACE DECIMAL ±0.010 THREE PLACE DECIMAL ±0.005 FOUR PLACE DECIMAL ±0.0005 ANGLES ±.25° UNMARKED FILLETS/ROUNDS R.0625 DE-BURR ALL PARTS		DRAWN BY:	MAM	
PROPRIETARY AND CONFIDENTIAL		INTERPRET GEOMETRIC TOLERANCING PER:				TITLE:
THE INFORMATION CONTAINED IN THIS DRAWING IS THE SOLE PROPERTY OF LASERLINC, INC. ANY REPRODUCTION IN PART OR AS A WHOLE WITHOUT THE WRITTEN PERMISSION OF LASERLINC, INC IS PROHIBITED.		MATERIAL		63 RA SURFACE FINISH ALL FEATURES MUST MEET SPECIFICATION AFTER PLATING BEFORE POWDER-COAT IF PLATED OR POWDER-COATED SEE FINISH MACHINE ALL SURFACES		SIZE
		FINISH				DWG. NO.
		DO NOT SCALE DRAWING				REV
						A
				SCALE: 2:3		SHEET 1 OF 3

8

7

6

5

4

3

2

1

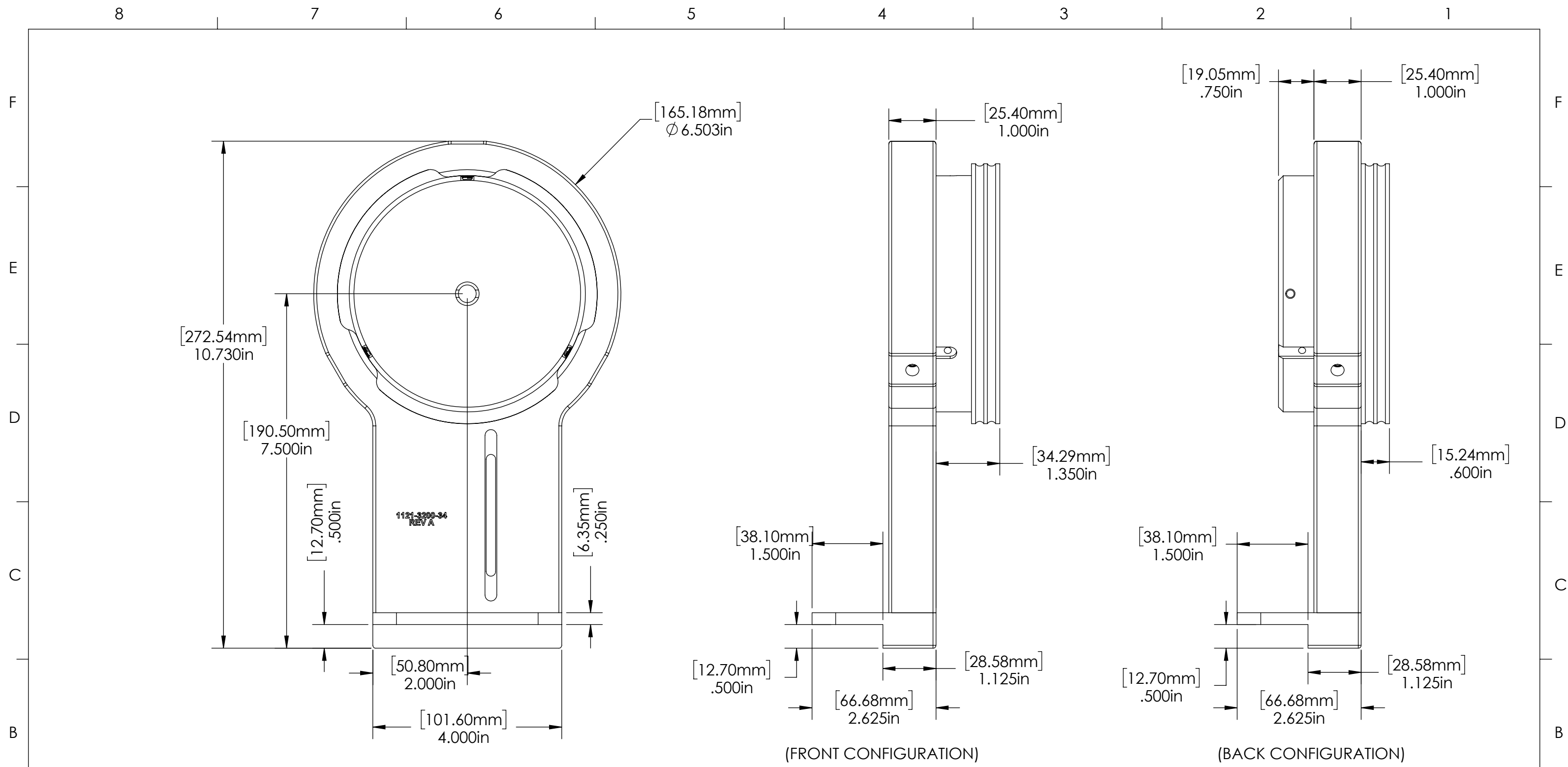



(FRONT CONFIGURATION)

(BACK CONFIGURATION)

GENERAL FINISH NOTE		UNLESS OTHERWISE SPECIFIED:		NAME	DATE
DE-BURR AND BREAK ALL SHARP EDGES BEFORE FINISH AND/OR SHIPPING		DIMENSIONS ARE IN INCHES TOLERANCES: ANGULAR: MACH ± BEND ± TWO PLACE DECIMAL ±0.010 THREE PLACE DECIMAL ±0.005 FOUR PLACE DECIMAL ±0.0005 ANGLES ±.25° UNMARKED FILLETS/ROUNDS R.0625 DE-BURR ALL PARTS		DRAWN BY:	MAM 11/4/2019
PROPRIETARY AND CONFIDENTIAL		INTERPRET GEOMETRIC TOLERANCING PER:		TITLE:	
THE INFORMATION CONTAINED IN THIS DRAWING IS THE SOLE PROPERTY OF LASERLINC, INC. ANY REPRODUCTION IN PART OR AS A WHOLE WITHOUT THE WRITTEN PERMISSION OF LASERLINC, INC. IS PROHIBITED.		MATERIAL		1120-0000-34 Calibration Fixture for TLAser1120 Micrometer Overall Dimensions	
FINISH		63 RA SURFACE FINISH ALL FEATURES MUST MEET SPECIFICATION AFTER PLATING BEFORE POWDER-COAT IF PLATED OR POWDER-COATED SEE FINISH MACHINE ALL SURFACES		SIZE	REV
DO NOT SCALE DRAWING				B	A
				DWG. NO.	
				1120-0000-34	
				SCALE: 1:2	SHEET 2 OF 3

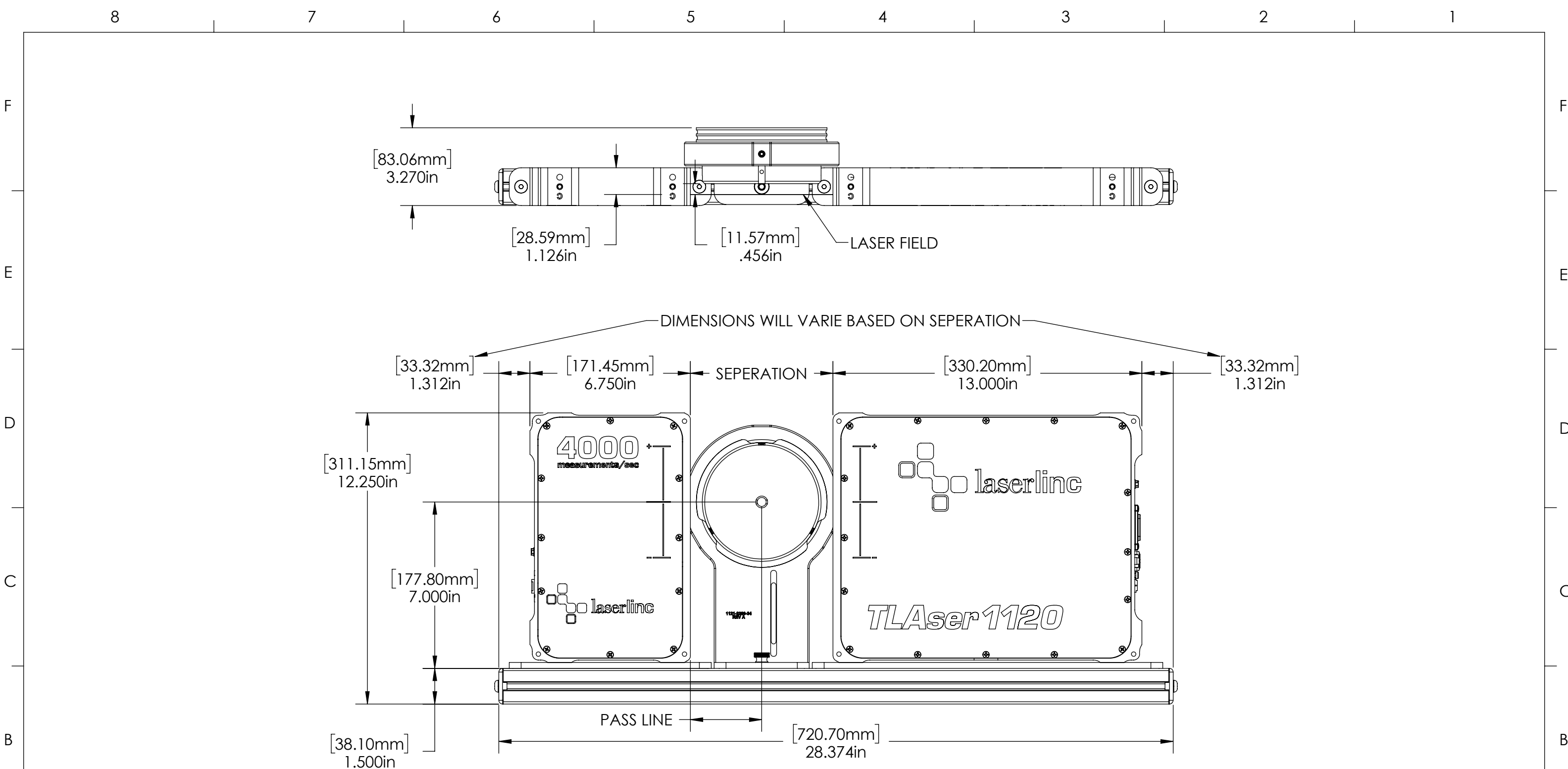
laserlinc LaserLinc, Inc.
Phone: 888-707-4892
Info@laserlinc.com
www.laserlinc.com



GENERAL FINISH NOTE DE-BURR AND BREAK ALL SHARP EDGES BEFORE FINISH AND/OR SHIPPING PROPRIETARY AND CONFIDENTIAL THE INFORMATION CONTAINED IN THIS DRAWING IS THE SOLE PROPERTY OF LASERLINC, INC. ANY REPRODUCTION IN PART OR AS A WHOLE WITHOUT THE WRITTEN PERMISSION OF LASERLINC, INC IS PROHIBITED.	UNLESS OTHERWISE SPECIFIED: DIMENSIONS ARE IN INCHES TOLERANCES: ANGULAR: MACH ± BEND ± TWO PLACE DECIMAL ±0.010 THREE PLACE DECIMAL ±0.005 FOUR PLACE DECIMAL ±0.0005 ANGLES ±.25° UNMARKED FILLETS/ROUNDS R.0625 DE-BURR ALL PARTS	NAME DATE MAM 11/4/2019	 LaserLinc, Inc. Phone: 888-707-4892 Info@laserlinc.com www.laserlinc.com			
	INTERPRET GEOMETRIC TOLERANCING PER:	DRAWN BY:		TITLE: 1120-0000-34 Calibration Fixture for TLAser1120 Micrometer Overall Dimensions		
	MATERIAL	63 RA SURFACE FINISH ALL FEATURES MUST MEET SPECIFICATION AFTER PLATING BEFORE POWDER-COAT IF PLATED OR POWDER-COATED SEE FINISH MACHINE ALL SURFACES		SIZE B	DWG. NO. 1120-0000-34	REV A
	FINISH DO NOT SCALE DRAWING	SCALE: 1:2		SHEET 3 OF 3		