

REVISIONS

ECO	REV.	DESCRIPTION	DATE	APPROVED
	A	CHECK-IN	12/04/2023	CJM

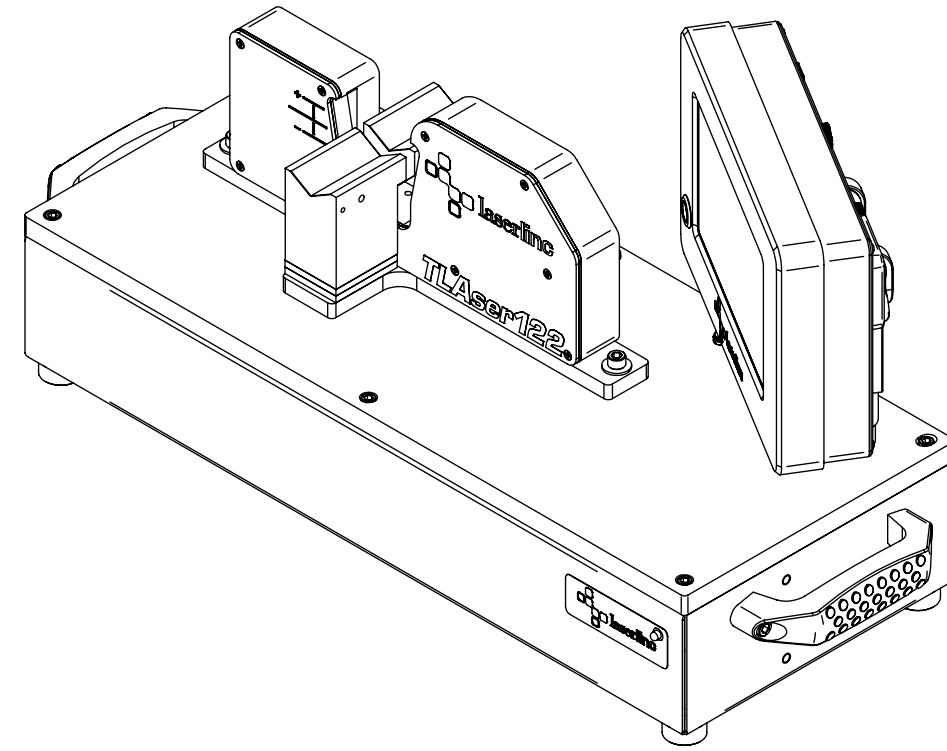



# TLASER122 BENCHLINC V WITH SMARTLINC DISPLAY

## INDEX

- (1) COVER PAGE
- (2) BOM TABLE
- (3) STEP 1
- (4) STEP 2
- (5) STEP 3
- (6) DIMENSIONS

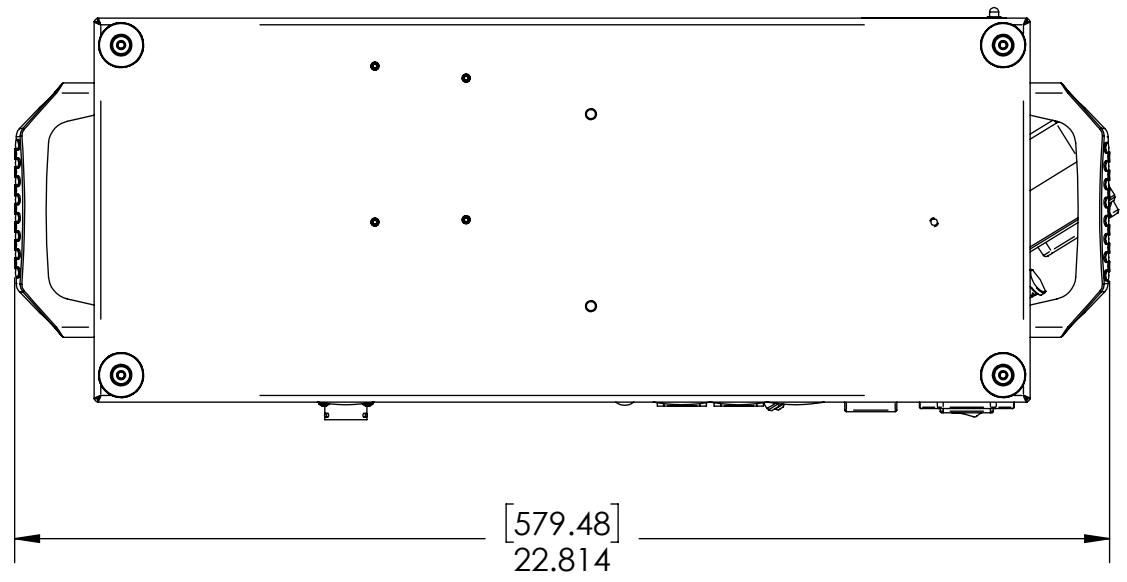
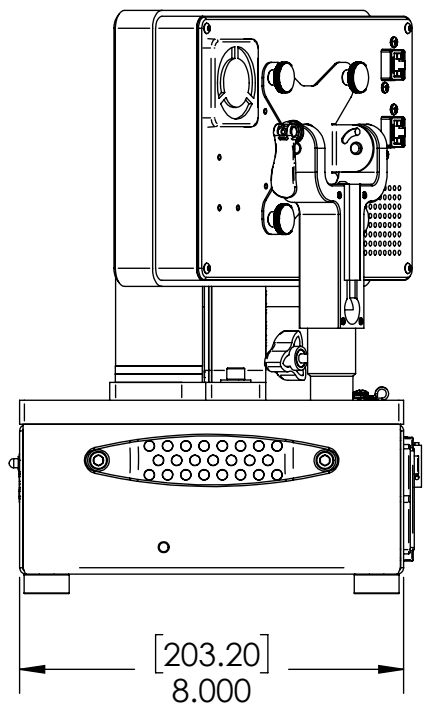
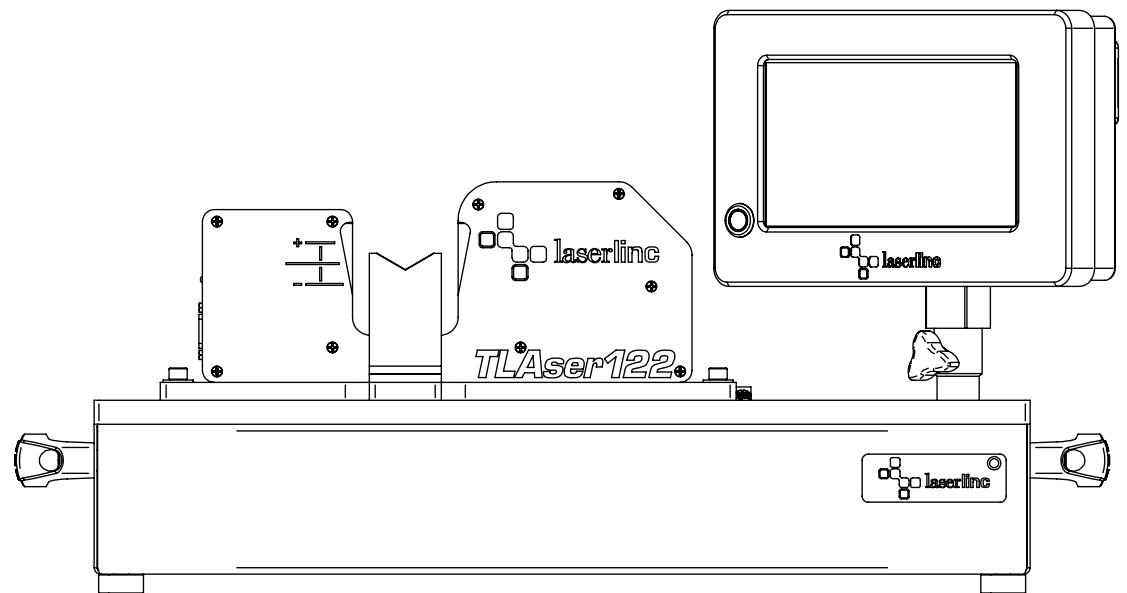
<b>GENERAL FINISH NOTE</b>		UNLESS OTHERWISE SPECIFIED:		NAME	DATE	 <b>LASERLINC, INC.</b> PHONE: 937-318-2440 INFO@LASERLINC.COM WWW.LASERLINC.COM
<b>DE-BURR AND BREAK</b> <b>ALL SHARP EDGES</b> <b>BEFORE FINISH AND/OR SHIPPING</b>		DIMENSIONS ARE IN INCHES TOLERANCES: ANGLES ±.25° TWO PLACE DECIMAL ±0.010 THREE PLACE DECIMAL ±0.005 FOUR PLACE DECIMAL ±0.0005 UNMARKED FILLETS/CHAMFER .06 DE-BURR ALL PARTS		DRAWN BY:	CJM	
<b>PROPRIETARY AND CONFIDENTIAL</b> THE INFORMATION CONTAINED IN THIS DRAWING IS THE SOLE PROPERTY OF LASERLINC, INC. ANY REPRODUCTION IN PART OR AS A WHOLE WITHOUT THE WRITTEN PERMISSION OF LASERLINC, INC. IS PROHIBITED.		INTERPRET GEOMETRIC TOLERANCING PER: ASME Y14.5				TITLE: TLASER122 BENCHLINC V WITH SMARTLINC DISPLAY
		MATERIAL		63 RA SURFACE FINISH		SIZE <b>B</b>
		FINISH		ALL FEATURES MUST MEET SPECIFICATION AFTER PLATING BEFORE POWDER-COAT IF PLATED OR POWDER-COATED		DWG. NO. 0122-0003-21
		DO NOT SCALE DRAWING		<b>SEE FINISH</b>		REV <b>A</b>
				SCALE: 1:4		SHEET 1 OF 6



<b>GENERAL FINISH NOTE</b>		UNLESS OTHERWISE SPECIFIED:		NAME	DATE
<b>DE-BURR AND BREAK ALL SHARP EDGES BEFORE FINISH AND/OR SHIPPING</b>		DIMENSIONS ARE IN INCHES TOLERANCES: ANGLES ±.25 TWO PLACE DECIMAL ±0.010 THREE PLACE DECIMAL ±0.005 FOUR PLACE DECIMAL ±0.0005 UNMARKED FILLETS/CHAMFER .06 DE-BURR ALL PARTS		DRAWN BY:	CJM 12/04/2023
<b>PROPRIETARY AND CONFIDENTIAL</b>		INTERPRET GEOMETRIC TOLERANCING PER: ASME Y14.5			
THE INFORMATION CONTAINED IN THIS DRAWING IS THE SOLE PROPERTY OF LASERLINC, INC. ANY REPRODUCTION IN PART OR AS A WHOLE WITHOUT THE WRITTEN PERMISSION OF LASERLINC, INC. IS PROHIBITED.		MATERIAL		63 RA SURFACE FINISH ALL FEATURES MUST MEET SPECIFICATION AFTER PLATING BEFORE POWDER-COAT IF PLATED OR POWDER-COATED <b>SEE FINISH</b>	
		FINISH			
		DO NOT SCALE DRAWING			
				 <b>LASERLINC, INC.</b> PHONE: 937-318-2440 INFO@LASERLINC.COM WWW.LASERLINC.COM	
				TITLE: TLASER122 BENCHLINECV WITH SMARTLINEC DISPLAY	
		SIZE	DWG. NO.	REV	
		<b>B</b>	0122-0003-21	<b>A</b>	
			SCALE: 1:4	SHEET 6 OF 6	