

8

7

6

5

4

3

2

1

F

E

D

C

B

A

F

E

D

C

B

A

REVISIONS				
ZONE	REV.	DESCRIPTION	DATE	APPROVED
	A	CHECK-IN	10/19/2020	EMM
	B	CHANGED VESA MOUNT	3/7/2022	EMM

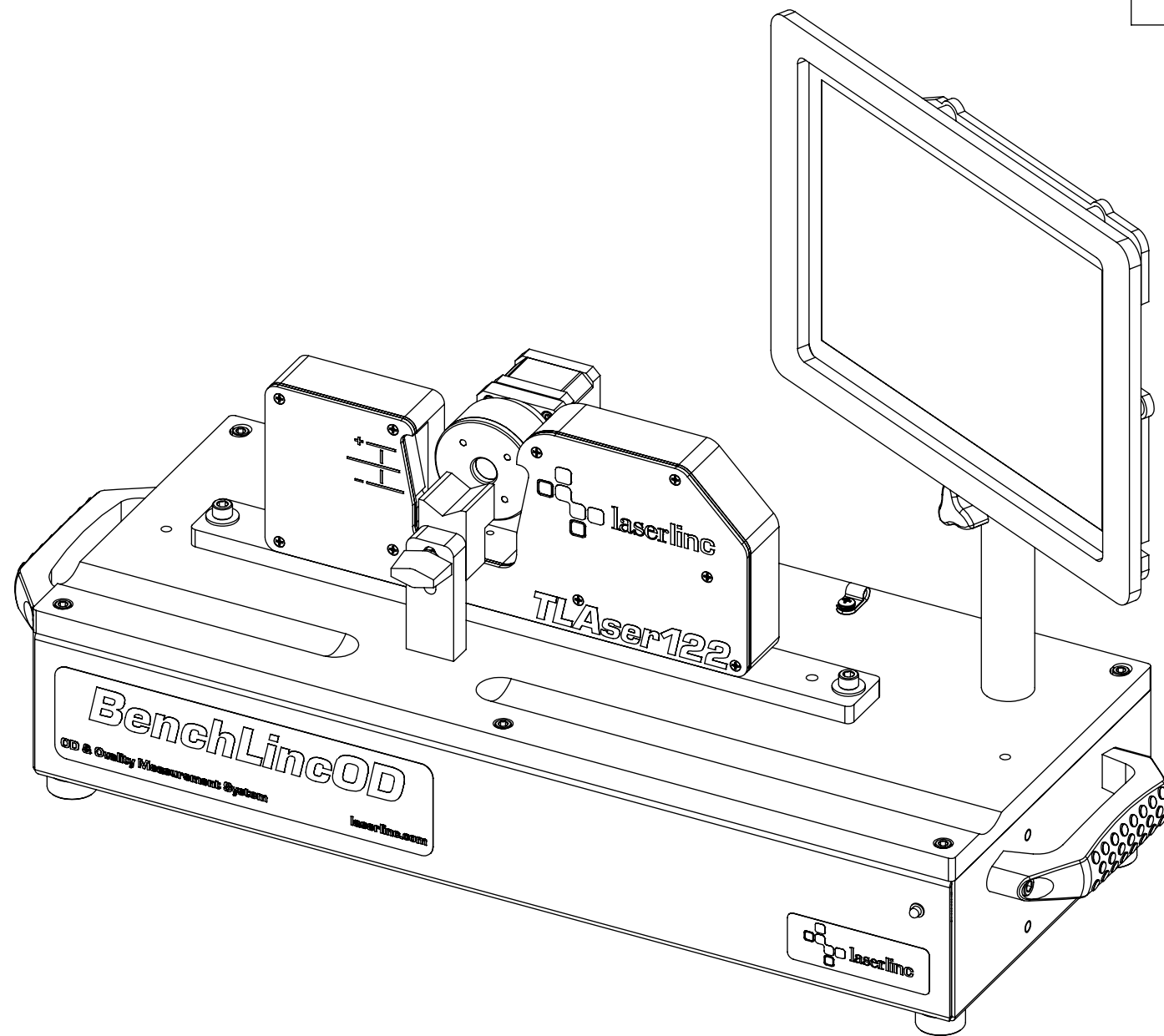

1/2IN BENCHLINC OD, TLASER122 MEASUREMENT SYSTEM

INDEX

- (1) COVER PAGE
- (2) BOM TABLE
- (3) MOUNT ZERO CHUCK
- (4) ASSEMBLE VESA MOUNT
- (5) OVERALLS

GENERAL FINISH NOTE		UNLESS OTHERWISE SPECIFIED:		NAME	DATE
DE-BURR AND BREAK ALL SHARP EDGES BEFORE FINISH AND/OR SHIPPING		DIMENSIONS ARE IN INCHES TOLERANCES: ANGLES ±.25 TWO PLACE DECIMAL ±0.010 THREE PLACE DECIMAL ±0.005 FOUR PLACE DECIMAL ±0.0005 UNMARKED FILLETS/CHAMFER .06 DE-BURR ALL PARTS		DRAWN BY:	EMM 10/19/2020
PROPRIETARY AND CONFIDENTIAL		INTERPRET GEOMETRIC TOLERANCING PER: ASME Y14.5			
THE INFORMATION CONTAINED IN THIS DRAWING IS THE SOLE PROPERTY OF LASERLINC, INC. ANY REPRODUCTION IN PART OR AS A WHOLE WITHOUT THE WRITTEN PERMISSION OF LASERLINC, INC. IS PROHIBITED.		MATERIAL		63 RA SURFACE FINISH ALL FEATURES MUST MEET SPECIFICATION AFTER PLATING BEFORE POWDER-COAT IF PLATED OR POWDER-COATED SEE FINISH	
		FINISH			
		DO NOT SCALE DRAWING			
			LASERLINC, INC. PHONE: 888-707-4892 INFO@LASERLINC.COM WWW.LASERLINC.COM		
TITLE: 1/2IN BENCHLINC OD, TLASER122 MEASUREMENT SYSTEM					
SIZE	DWG. NO.	REV			
B	6122-0007-00	B			
SCALE: 1:3			SHEET 1 OF 5		

8

7

6

5

4

3

2

1

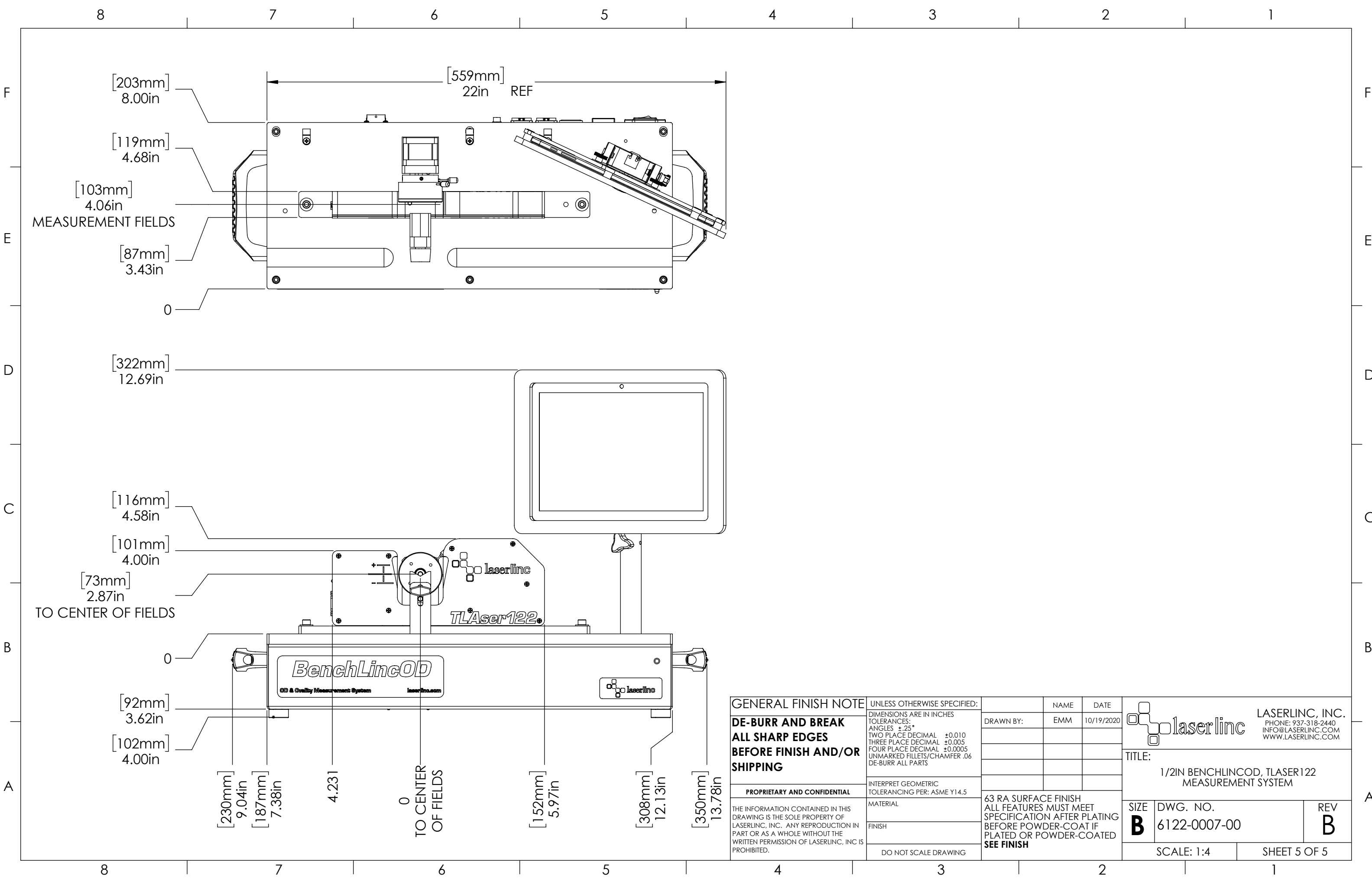

MEASUREMENT FIELDS

TO CENTER OF FIELDS

TO CENTER OF FIELDS

GENERAL FINISH NOTE		UNLESS OTHERWISE SPECIFIED:		NAME	DATE
DE-BURR AND BREAK ALL SHARP EDGES BEFORE FINISH AND/OR SHIPPING		DIMENSIONS ARE IN INCHES TOLERANCES: ANGLES ±.25 TWO PLACE DECIMAL ±0.010 THREE PLACE DECIMAL ±0.005 FOUR PLACE DECIMAL ±0.0005 UNMARKED FILLETS/CHAMFER .06 DE-BURR ALL PARTS		DRAWN BY:	EMM 10/19/2020
PROPRIETARY AND CONFIDENTIAL		INTERPRET GEOMETRIC TOLERANCING PER: ASME Y14.5			
THE INFORMATION CONTAINED IN THIS DRAWING IS THE SOLE PROPERTY OF LASERLINC, INC. ANY REPRODUCTION IN PART OR AS A WHOLE WITHOUT THE WRITTEN PERMISSION OF LASERLINC, INC. IS PROHIBITED.		MATERIAL		63 RA SURFACE FINISH ALL FEATURES MUST MEET SPECIFICATION AFTER PLATING BEFORE POWDER-COAT IF PLATED OR POWDER-COATED SEE FINISH	
		FINISH		TITLE: 1/2IN BENCHLINCOD, TLASER122 MEASUREMENT SYSTEM	
		DO NOT SCALE DRAWING		SIZE B	DWG. NO. 6122-0007-00
				SCALE: 1:4	REV B
				SHEET 5 OF 5	



LASERLINC, INC.
PHONE: 937-318-2440
INFO@LASERLINC.COM
WWW.LASERLINC.COM