

8

7

6

5

4

3

2

1

F

E

D

C

B

A

F

E

D

C

B

A

REVISIONS

ZONE	REV.	DESCRIPTION	DATE	APPROVED
	A	CHECK-IN	10/20/2020	EMM
	B	CHANGED ITEM 25 TO 1/4IN ZERO CHUCK BUSHING	12/14/2020	MAM
	C	CHANGED VESA MOUNT	3/7/2022	EMM

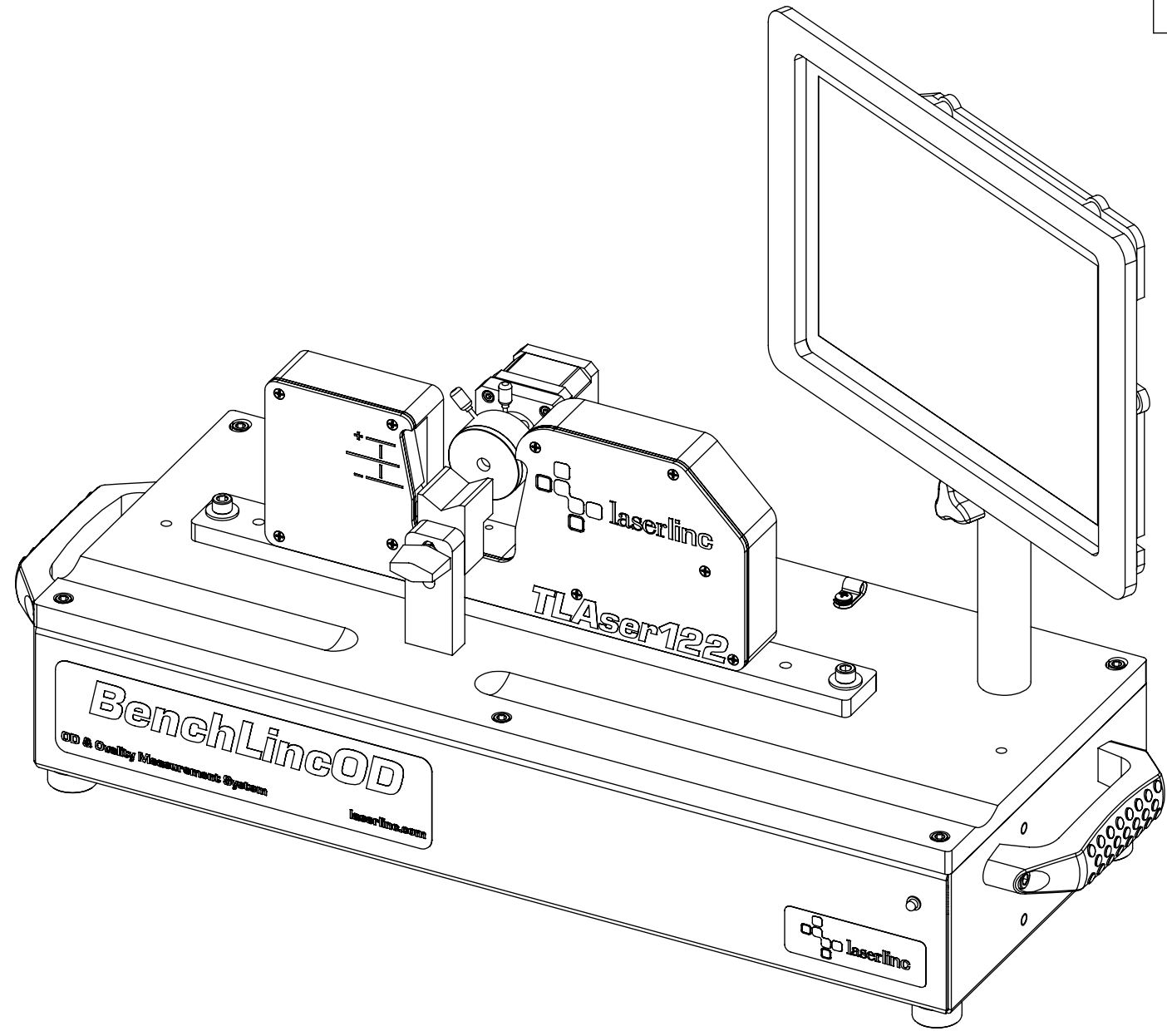

# 1/4IN BENCHLINC OD, TLASER122 MEASUREMENT SYSTEM

### INDEX

- (1) COVER PAGE
- (2) BOM TABLE
- (3) MOUNT ZERO CHUCK
- (4) ASSEMBLE VESA MOUNT
- (5) OVERALLS

<b>GENERAL FINISH NOTE</b>		UNLESS OTHERWISE SPECIFIED:		NAME	DATE	 <b>LASERLINC, INC.</b> PHONE: 888-707-4892 INFO@LASERLINC.COM WWW.LASERLINC.COM
<b>DE-BURR AND BREAK ALL SHARP EDGES BEFORE FINISH AND/OR SHIPPING</b>		DIMENSIONS ARE IN INCHES TOLERANCES: ANGLES ±.25° TWO PLACE DECIMAL ±0.010 THREE PLACE DECIMAL ±0.005 FOUR PLACE DECIMAL ±0.0005 UNMARKED FILLETS/CHAMFER .06 DE-BURR ALL PARTS		DRAWN BY:	EMM	
<b>PROPRIETARY AND CONFIDENTIAL</b>		INTERPRET GEOMETRIC TOLERANCING PER: ASME Y14.5				
THE INFORMATION CONTAINED IN THIS DRAWING IS THE SOLE PROPERTY OF LASERLINC, INC. ANY REPRODUCTION IN PART OR AS A WHOLE WITHOUT THE WRITTEN PERMISSION OF LASERLINC, INC. IS PROHIBITED.		MATERIAL		63 RA SURFACE FINISH ALL FEATURES MUST MEET SPECIFICATION AFTER PLATING BEFORE POWDER-COAT IF PLATED OR POWDER-COATED <b>SEE FINISH</b>		TITLE: 1/4IN BENCHLINC OD, TLASER122 MEASUREMENT SYSTEM
		FINISH		SIZE <b>B</b> DWG. NO. 6122-0008-00		REV <b>C</b>
		DO NOT SCALE DRAWING		SCALE: 1:3		SHEET 1 OF 5

8

7

6

5

4

3

2

1

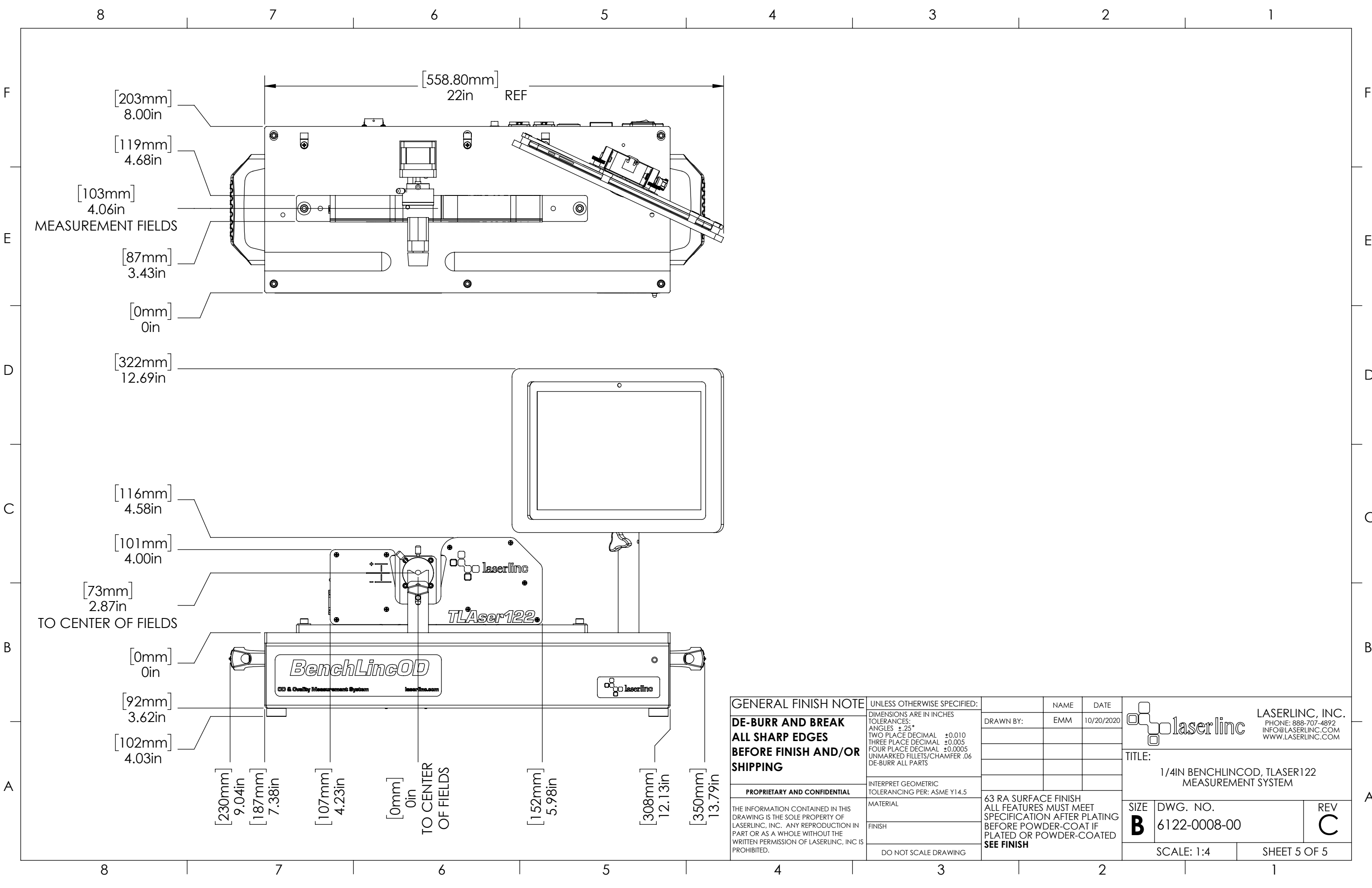

[203mm]  
8.00in

[119mm]  
4.68in

[103mm]  
4.06in  
MEASUREMENT FIELDS

[87mm]  
3.43in

[0mm]  
0in

[322mm]  
12.69in

[558.80mm]  
22in REF

[116mm]  
4.58in

[101mm]  
4.00in

[73mm]  
2.87in  
TO CENTER OF FIELDS

[0mm]  
0in

[92mm]  
3.62in

[102mm]  
4.03in

[230mm]  
9.04in

[187mm]  
7.38in

[107mm]  
4.23in

[0mm]  
0in  
TO CENTER  
OF FIELDS

[152mm]  
5.98in

[308mm]  
12.13in

[350mm]  
13.79in

**GENERAL FINISH NOTE**

**DE-BURR AND BREAK  
ALL SHARP EDGES  
BEFORE FINISH AND/OR  
SHIPPING**

**PROPRIETARY AND CONFIDENTIAL**

THE INFORMATION CONTAINED IN THIS DRAWING IS THE SOLE PROPERTY OF LASERLINC, INC. ANY REPRODUCTION IN PART OR AS A WHOLE WITHOUT THE WRITTEN PERMISSION OF LASERLINC, INC. IS PROHIBITED.

UNLESS OTHERWISE SPECIFIED:  
DIMENSIONS ARE IN INCHES  
TOLERANCES:  
ANGLES ±.25°  
TWO PLACE DECIMAL ±0.010  
THREE PLACE DECIMAL ±0.005  
FOUR PLACE DECIMAL ±0.0005  
UNMARKED FILLETS/CHAMFER .06  
DE-BURR ALL PARTS

INTERPRET GEOMETRIC TOLERANCING PER: ASME Y14.5

MATERIAL

FINISH

DO NOT SCALE DRAWING

NAME	DATE
EMM	10/20/2020

63 RA SURFACE FINISH  
ALL FEATURES MUST MEET SPECIFICATION AFTER PLATING BEFORE POWDER-COAT IF PLATED OR POWDER-COATED  
**SEE FINISH**

**laserlinc** LASERLINC, INC.  
PHONE: 888-707-4892  
INFO@LASERLINC.COM  
WWW.LASERLINC.COM

TITLE:  
1/4IN BENCHLINCOD, TLASER122  
MEASUREMENT SYSTEM

SIZE <b>B</b>	DWG. NO. 6122-0008-00	REV <b>C</b>
------------------	--------------------------	-----------------

SCALE: 1:4 SHEET 5 OF 5