

8

7

6

5

4

3

2

1

F

E

D

C

B

A

F

E

D

C

B

A

REVISIONS

ZONE	REV.	DESCRIPTION	DATE	APPROVED
	A	CHECK-IN	10/20/2020	EMM
	B	CHANGE ITEM 25 1/4 ZERO CHUCK BUSHING	12/14/2020	MAM

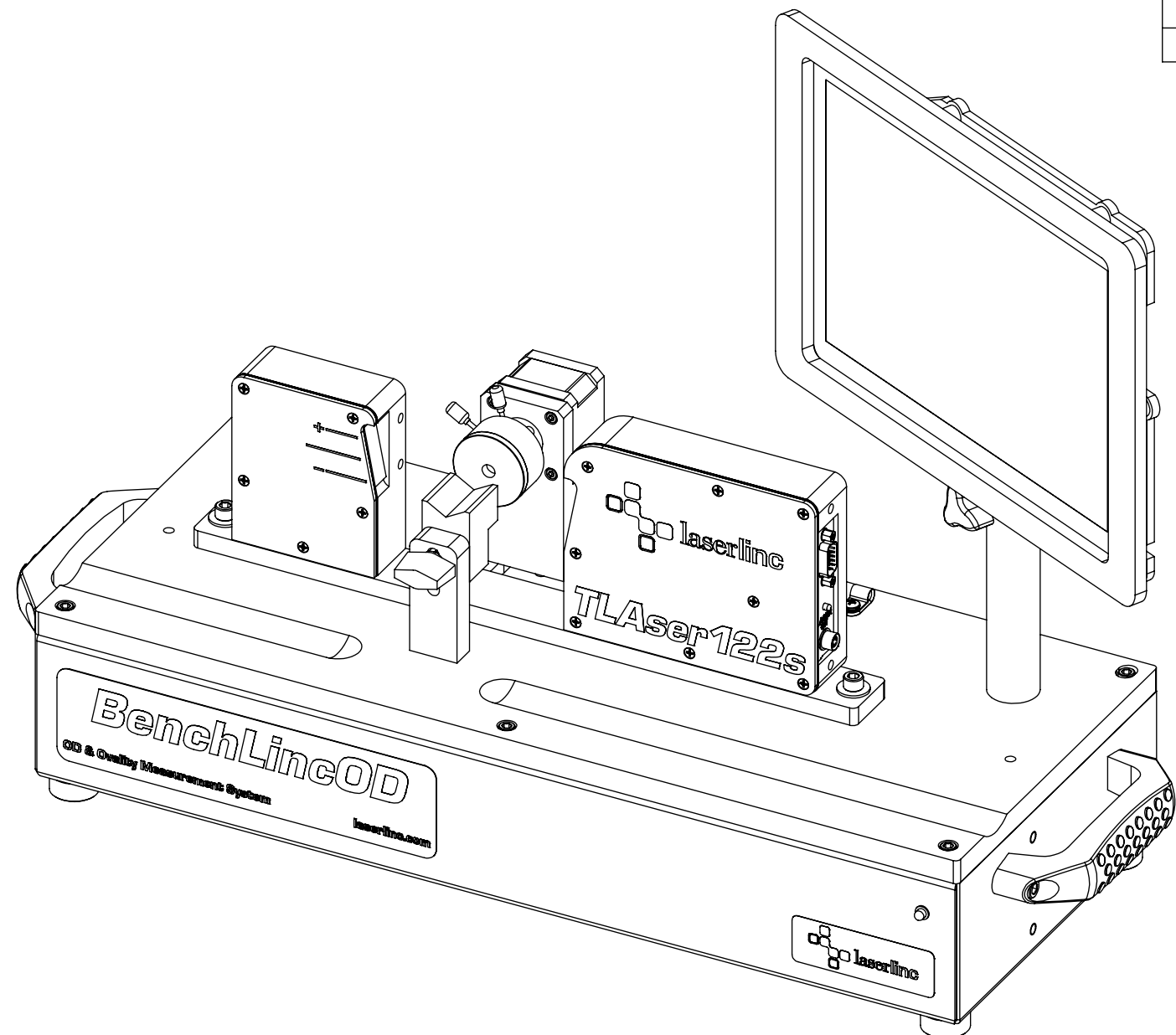

1/4IN BENCHLINC OD, TLASER122S MEASUREMENT SYSTEM

INDEX

- (1) COVER PAGE
- (2) BOM TABLE
- (3) MOUNT ZERO CHUCK
- (4) ASSEMBLE VESA MOUNT
- (5) OVERALLS

GENERAL FINISH NOTE		UNLESS OTHERWISE SPECIFIED:		NAME	DATE	 LASERLINC, INC. PHONE: 888-707-4892 INFO@LASERLINC.COM WWW.LASERLINC.COM
DE-BURR AND BREAK ALL SHARP EDGES BEFORE FINISH AND/OR SHIPPING		DIMENSIONS ARE IN INCHES TOLERANCES: ANGLES ±.25 TWO PLACE DECIMAL ±0.010 THREE PLACE DECIMAL ±0.005 FOUR PLACE DECIMAL ±0.0005 UNMARKED FILLETS/CHAMFER .06 DE-BURR ALL PARTS		DRAWN BY:	EMM	
PROPRIETARY AND CONFIDENTIAL		INTERPRET GEOMETRIC TOLERANCING PER: ASME Y14.5				
THE INFORMATION CONTAINED IN THIS DRAWING IS THE SOLE PROPERTY OF LASERLINC, INC. ANY REPRODUCTION IN PART OR AS A WHOLE WITHOUT THE WRITTEN PERMISSION OF LASERLINC, INC. IS PROHIBITED.		MATERIAL		63 RA SURFACE FINISH		TITLE:
		FINISH		ALL FEATURES MUST MEET SPECIFICATION AFTER PLATING BEFORE POWDER-COAT IF PLATED OR POWDER-COATED		1/4IN BENCHLINC OD, TLASER122S MEASUREMENT SYSTEM
		DO NOT SCALE DRAWING		SEE FINISH		SIZE
						DWG. NO.
						6122-0011-00
						REV
						B
				SCALE: 1:3		SHEET 1 OF 5

8

7

6

5

4

3

2

1

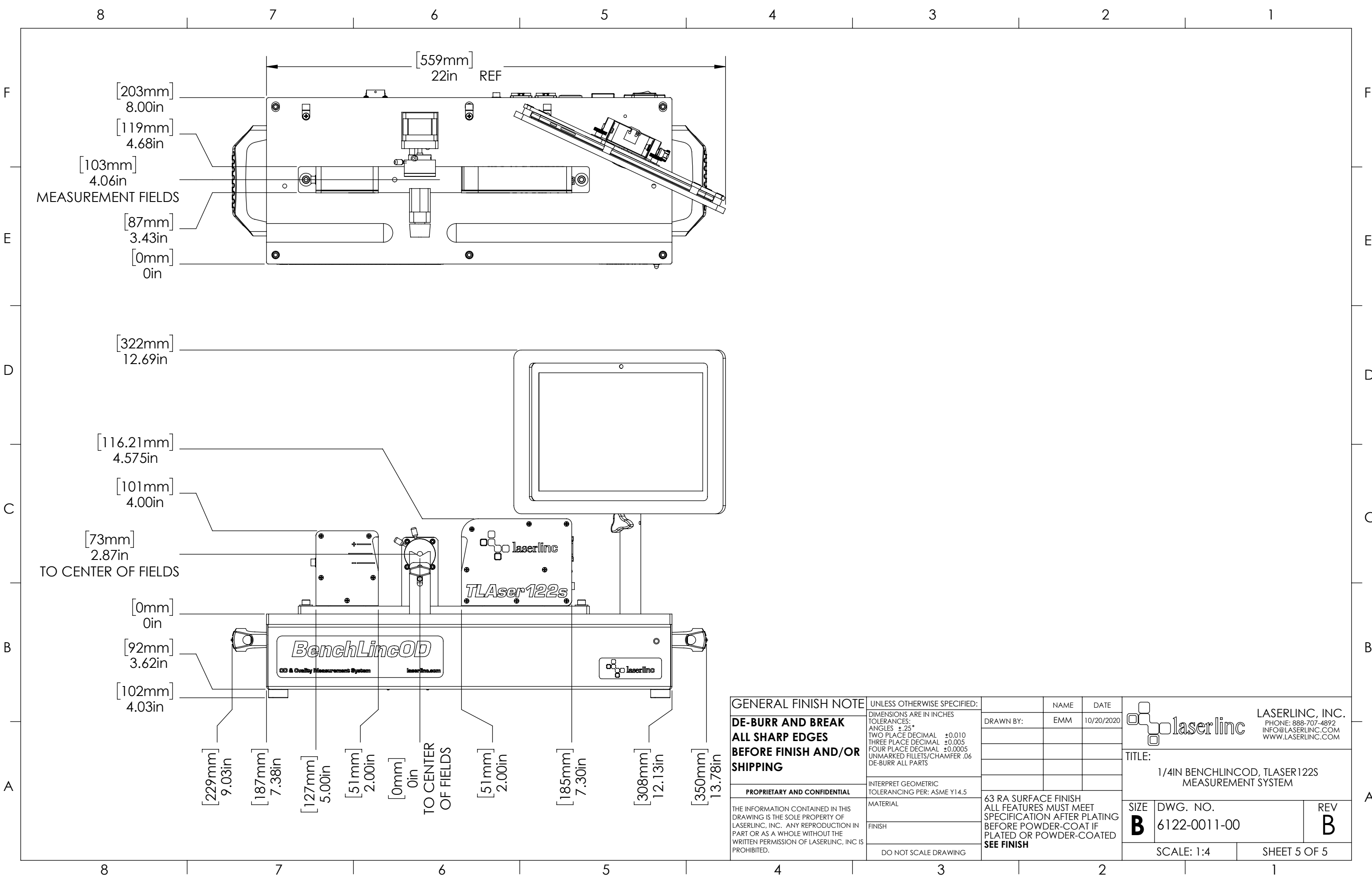

GENERAL FINISH NOTE
DE-BURR AND BREAK
ALL SHARP EDGES
BEFORE FINISH AND/OR
SHIPPING

PROPRIETARY AND CONFIDENTIAL

THE INFORMATION CONTAINED IN THIS DRAWING IS THE SOLE PROPERTY OF LASERLINC, INC. ANY REPRODUCTION IN PART OR AS A WHOLE WITHOUT THE WRITTEN PERMISSION OF LASERLINC, INC. IS PROHIBITED.

UNLESS OTHERWISE SPECIFIED:
 DIMENSIONS ARE IN INCHES
 TOLERANCES:
 ANGLES ±.25°
 TWO PLACE DECIMAL ±0.010
 THREE PLACE DECIMAL ±0.005
 FOUR PLACE DECIMAL ±0.0005
 UNMARKED FILLETS/CHAMFER .06
 DE-BURR ALL PARTS

INTERPRET GEOMETRIC TOLERANCING PER: ASME Y14.5

MATERIAL

FINISH

DO NOT SCALE DRAWING

NAME	DATE
EMM	10/20/2020

63 RA SURFACE FINISH
 ALL FEATURES MUST MEET SPECIFICATION AFTER PLATING BEFORE POWDER-COAT IF PLATED OR POWDER-COATED
SEE FINISH

laserlinc LASERLINC, INC.
 PHONE: 888-707-4892
 INFO@LASERLINC.COM
 WWW.LASERLINC.COM

TITLE:
 1/4IN BENCHLINCOD, TLASER122S
 MEASUREMENT SYSTEM

SIZE B	DWG. NO. 6122-0011-00	REV B
------------------	--------------------------	-----------------

SCALE: 1:4 SHEET 5 OF 5