

8

7

6

5

4

3

2

1

F

E

D

C

B

A

F

E

D

C

B

A

REVISIONS

ZONE	REV.	DESCRIPTION	DATE	APPROVED
	A	CHECK-IN	10/20/2020	EMM

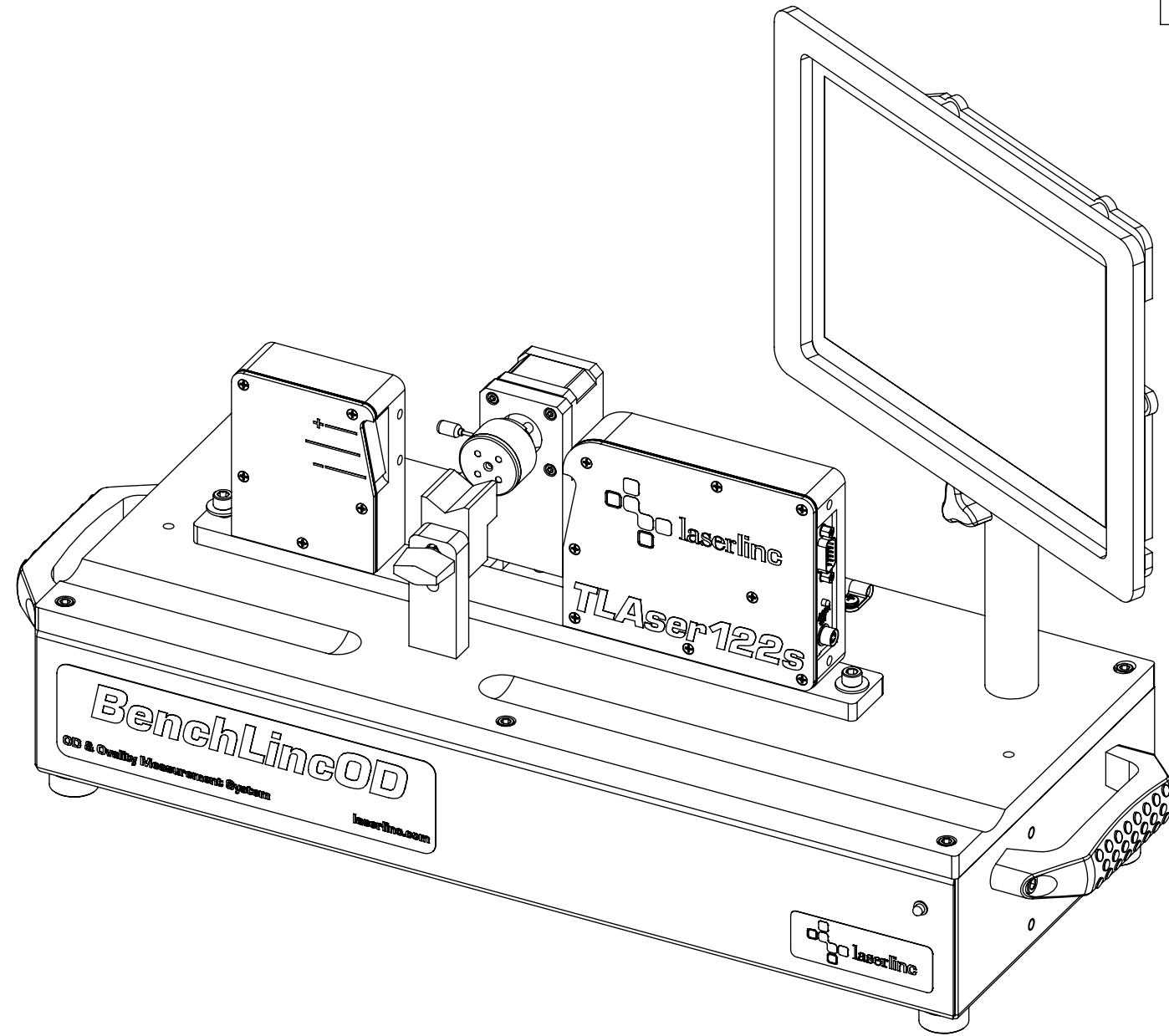

# 1/8IN BENCHLINC OD, TLASER122S MEASUREMENT SYSTEM

## INDEX

- (1) COVER PAGE
- (2) BOM TABLE
- (3) MOUNT ZERO CHUCK
- (4) ASSEMBLE VESA MOUNT
- (5) OVERALLS

<b>GENERAL FINISH NOTE</b>		UNLESS OTHERWISE SPECIFIED:		NAME	DATE	 <b>LASERLINC, INC.</b> PHONE: 888-707-4892 INFO@LASERLINC.COM WWW.LASERLINC.COM
<b>DE-BURR AND BREAK ALL SHARP EDGES BEFORE FINISH AND/OR SHIPPING</b>		DIMENSIONS ARE IN INCHES TOLERANCES: ANGLES ±.25° TWO PLACE DECIMAL ±0.010 THREE PLACE DECIMAL ±0.005 FOUR PLACE DECIMAL ±0.0005 UNMARKED FILLETS/CHAMFER .06 DE-BURR ALL PARTS		DRAWN BY:	EMM	
<b>PROPRIETARY AND CONFIDENTIAL</b>		INTERPRET GEOMETRIC TOLERANCING PER: ASME Y14.5				
THE INFORMATION CONTAINED IN THIS DRAWING IS THE SOLE PROPERTY OF LASERLINC, INC. ANY REPRODUCTION IN PART OR AS A WHOLE WITHOUT THE WRITTEN PERMISSION OF LASERLINC, INC. IS PROHIBITED.		MATERIAL		63 RA SURFACE FINISH		TITLE:
		FINISH		ALL FEATURES MUST MEET SPECIFICATION AFTER PLATING BEFORE POWDER-COAT IF PLATED OR POWDER-COATED		1/8IN BENCHLINC OD, TLASER122S MEASUREMENT SYSTEM
		DO NOT SCALE DRAWING		<b>SEE FINISH</b>		SIZE DWG. NO. REV
						<b>B</b> 6122-0012-00 <b>A</b>
				SCALE: 1:3		SHEET 1 OF 5

8

7

6

5

4

3

2

1

