

8

7

6

5

4

3

2

1

REVISIONS				
ZONE	REV.	DESCRIPTION	DATE	APPROVED
	A	Check-in	10/15/2014	MAM

F

F

E

E

D

D

C

C

B

B

A

A

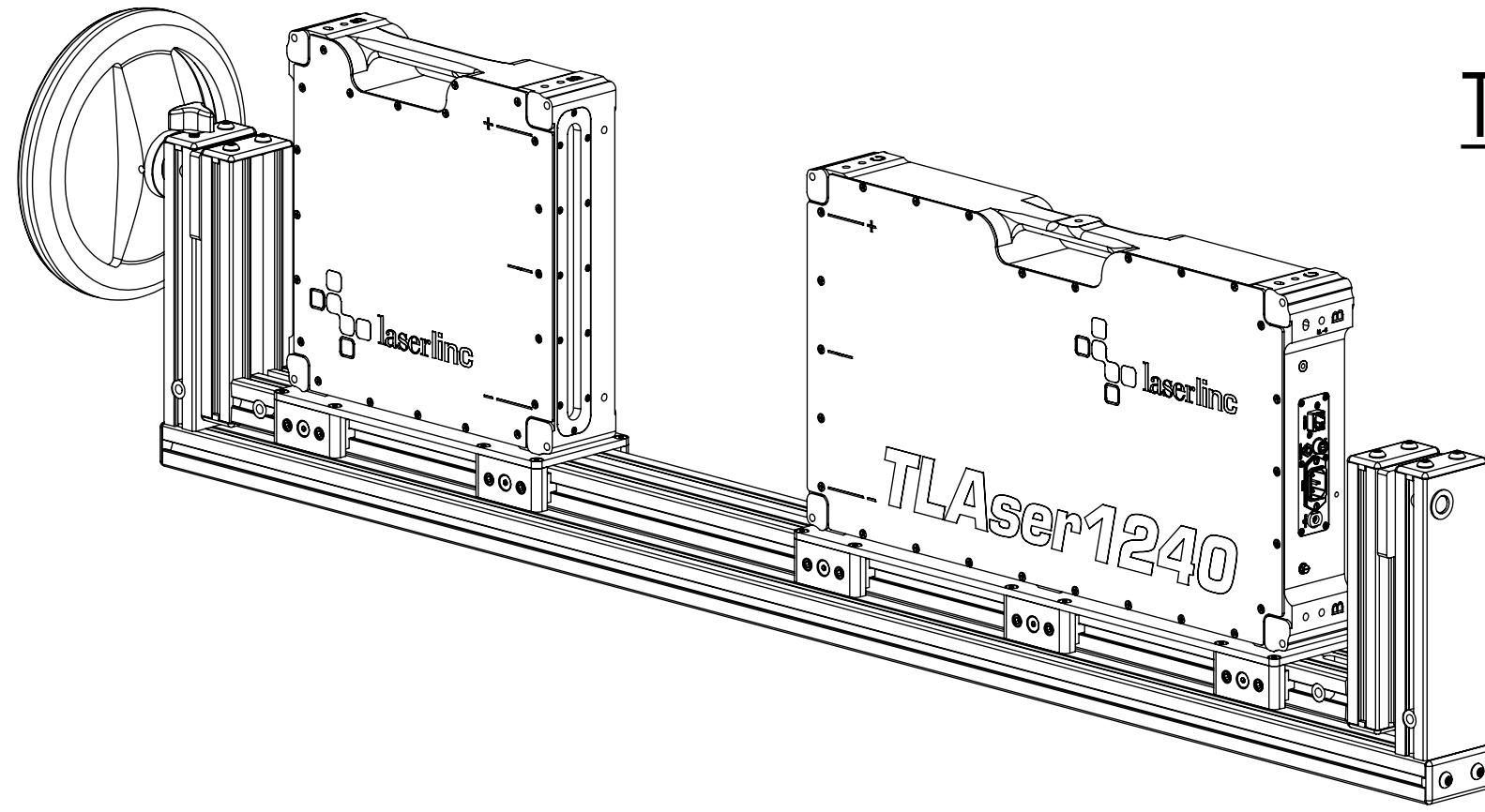

TILT FIXTURE FOR TLASER1240 MICROMETER OVERALL DIMENSIONS

INDEX

- (1) COVER PAGE
- (2) DIMENSIONS

GENERAL FINISH NOTE		UNLESS OTHERWISE SPECIFIED:		NAME	DATE	 LASERLINC, INC. PHONE: 888-707-4892 INFO@LASERLINC.COM WWW.LASERLINC.COM
DE-BURR AND BREAK ALL SHARP EDGES BEFORE FINISH AND/OR SHIPPING		DIMENSIONS ARE IN INCHES TOLERANCES: ANGLES ±.25° TWO PLACE DECIMAL ±0.010 THREE PLACE DECIMAL ±0.005 FOUR PLACE DECIMAL ±0.0005 UNMARKED FILLETS/CHAMFER .06 DE-BURR ALL PARTS		DRAWN BY:	MAM	
PROPRIETARY AND CONFIDENTIAL		INTERPRET GEOMETRIC TOLERANCING PER: ASME Y14.5				TITLE: 01240-32 TILT FIXTURE FOR TLASER1240 MICROMETER OVERALL DIMENSIONS
THE INFORMATION CONTAINED IN THIS DRAWING IS THE SOLE PROPERTY OF LASERLINC, INC. ANY REPRODUCTION IN PART OR AS A WHOLE WITHOUT THE WRITTEN PERMISSION OF LASERLINC, INC. IS PROHIBITED.		MATERIAL		63 RA SURFACE FINISH ALL FEATURES MUST MEET SPECIFICATION AFTER PLATING BEFORE POWDER-COAT IF PLATED OR POWDER-COATED SEE FINISH		SIZE B
		FINISH				DWG. NO. 01240-32
		DO NOT SCALE DRAWING				REV A
				SCALE: 1:6		SHEET 1 OF 2

8

7

6

5

4

3

2

1

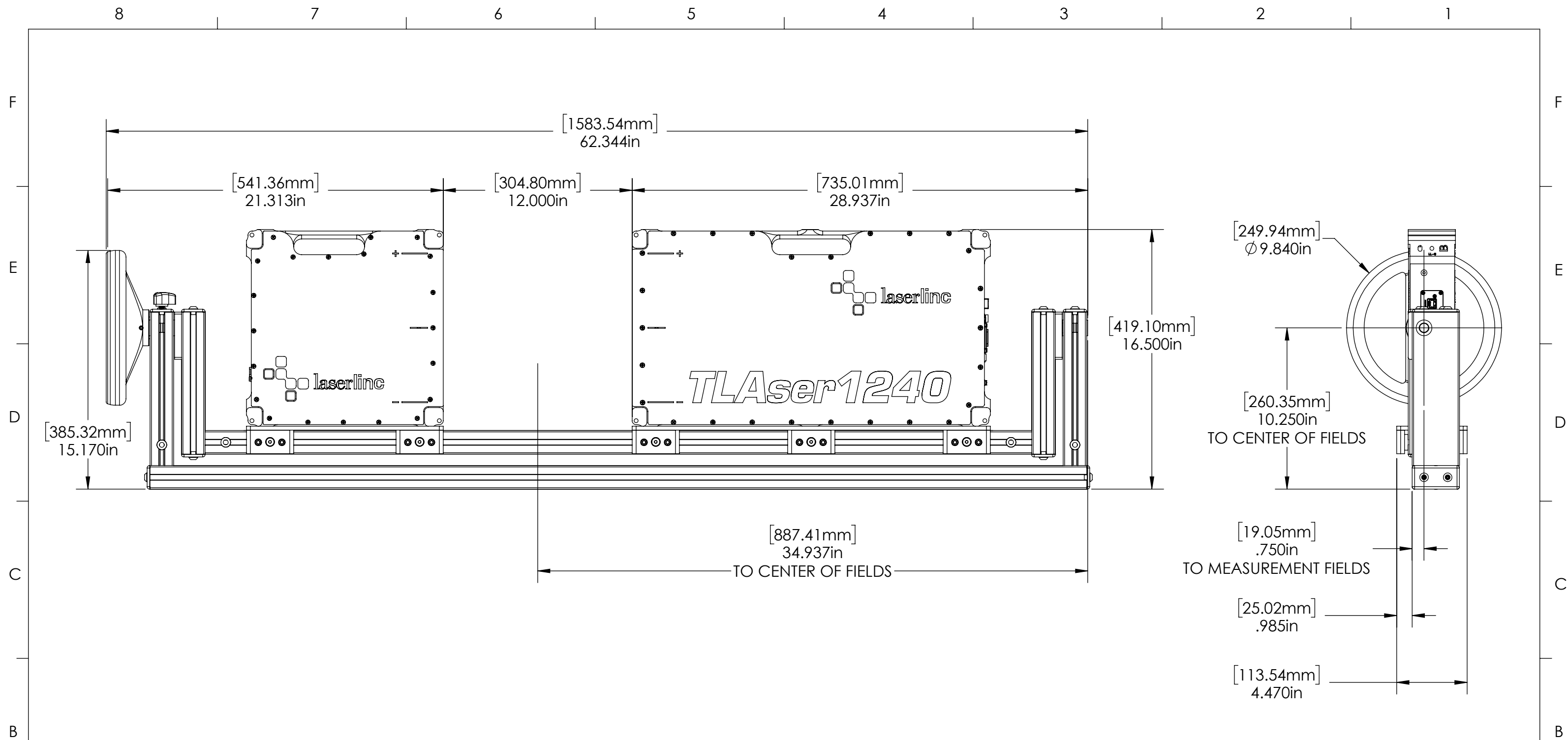

NOTES:
 • MOUNTING HARDWARE SPECIFICATION : FRAME-WORLD 5/16 PRODUCT LINE

GENERAL FINISH NOTE DE-BURR AND BREAK ALL SHARP EDGES BEFORE FINISH AND/OR SHIPPING	UNLESS OTHERWISE SPECIFIED: DIMENSIONS ARE IN INCHES TOLERANCES: ANGLES ±.25 TWO PLACE DECIMAL ±0.010 THREE PLACE DECIMAL ±0.005 FOUR PLACE DECIMAL ±0.0005 UNMARKED FILLETS/CHAMFER .06 DE-BURR ALL PARTS	NAME	DATE	 LASERLINC, INC. PHONE: 888-707-4892 INFO@LASERLINC.COM WWW.LASERLINC.COM
	INTERPRET GEOMETRIC TOLERANCING PER: ASME Y14.5	DRAWN BY:	MAM	
PROPRIETARY AND CONFIDENTIAL	MATERIAL	63 RA SURFACE FINISH ALL FEATURES MUST MEET SPECIFICATION AFTER PLATING BEFORE POWDER-COAT IF PLATED OR POWDER-COATED SEE FINISH		TITLE: 01240-32 TILT FIXTURE FOR TLASER1240 MICROMETER OVERALL DIMENSIONS
THE INFORMATION CONTAINED IN THIS DRAWING IS THE SOLE PROPERTY OF LASERLINC, INC. ANY REPRODUCTION IN PART OR AS A WHOLE WITHOUT THE WRITTEN PERMISSION OF LASERLINC, INC. IS PROHIBITED.	FINISH	SIZE	DWG. NO.	REV
DO NOT SCALE DRAWING		B	01240-32	A
		SCALE: 1:6		SHEET 2 OF 2