

8 7 6 5 4 3 2 1

REVISIONS				
ZONE	REV.	DESCRIPTION	DATE	APPROVED
	A	Check-In	1/11/2013	MAM

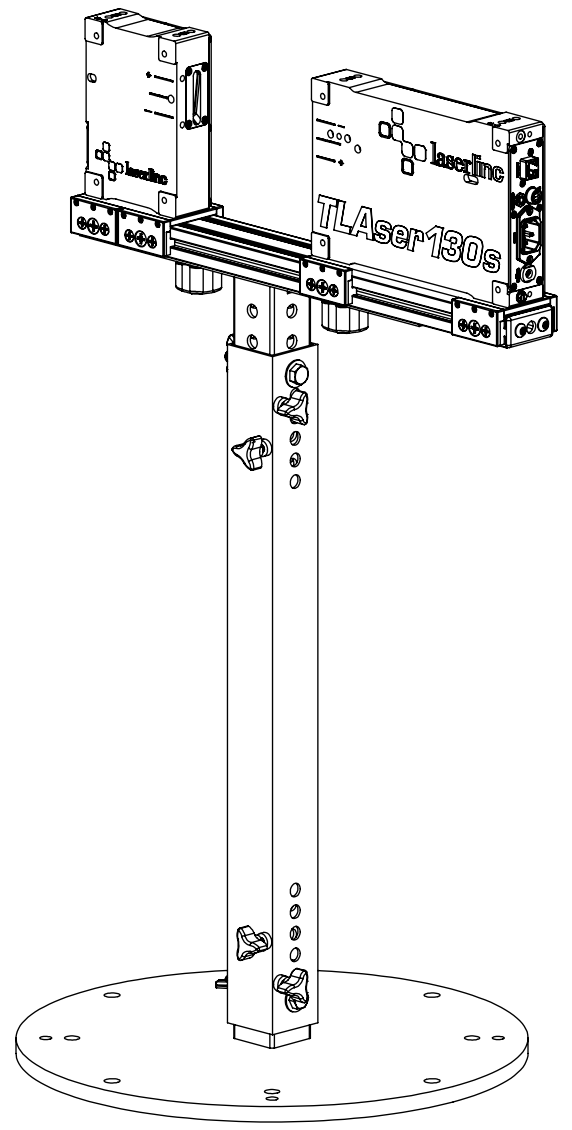

D
C
B
A

D
C
B
A

Stand for TLAser130 Micrometer Overall Dimensions

INDEX

- (1) Cover Page
- (2) Fixture Dimensions
- (3) Mounted Dimensions

UNLESS OTHERWISE SPECIFIED:		NAME	DATE	 LaserLinc, Inc. Phone: 888-707-4892 Info@laserlinc.com www.laserlinc.com
DIMENSIONS ARE IN INCHES TOLERANCES: ANGULAR: MACH ± BEND ± TWO PLACE DECIMAL ±0.010 THREE PLACE DECIMAL ±0.005 FOUR PLACE DECIMAL ±0.0005 ANGLES ±.25° UNMARKED FILLETS/ROUNDS R.0625 DE-BURR ALL PARTS		DRAWN BY:	MAM	
INTERPRET GEOMETRIC TOLERANCING PER:		63 RA SURFACE FINISH ALL FEATURES MUST MEET SPECIFICATION AFTER PLATING BEFORE POWDER-COAT IF PLATED OR POWDER-COATED SEE FINISH MACHINE ALL SURFACES		
PROPRIETARY AND CONFIDENTIAL THE INFORMATION CONTAINED IN THIS DRAWING IS THE SOLE PROPERTY OF LASERLINC, INC. ANY REPRODUCTION IN PART OR AS A WHOLE WITHOUT THE WRITTEN PERMISSION OF LASERLINC, INC IS PROHIBITED.		TITLE: 00130-28 Stand for TLAser130 Micrometer Overall Dimensions		
DO NOT SCALE DRAWING		SIZE	DWG. NO.	REV
		B	00130-28	A
		SCALE: 1:6		SHEET 1 OF 3

8 7 6 5 4 3 2 1

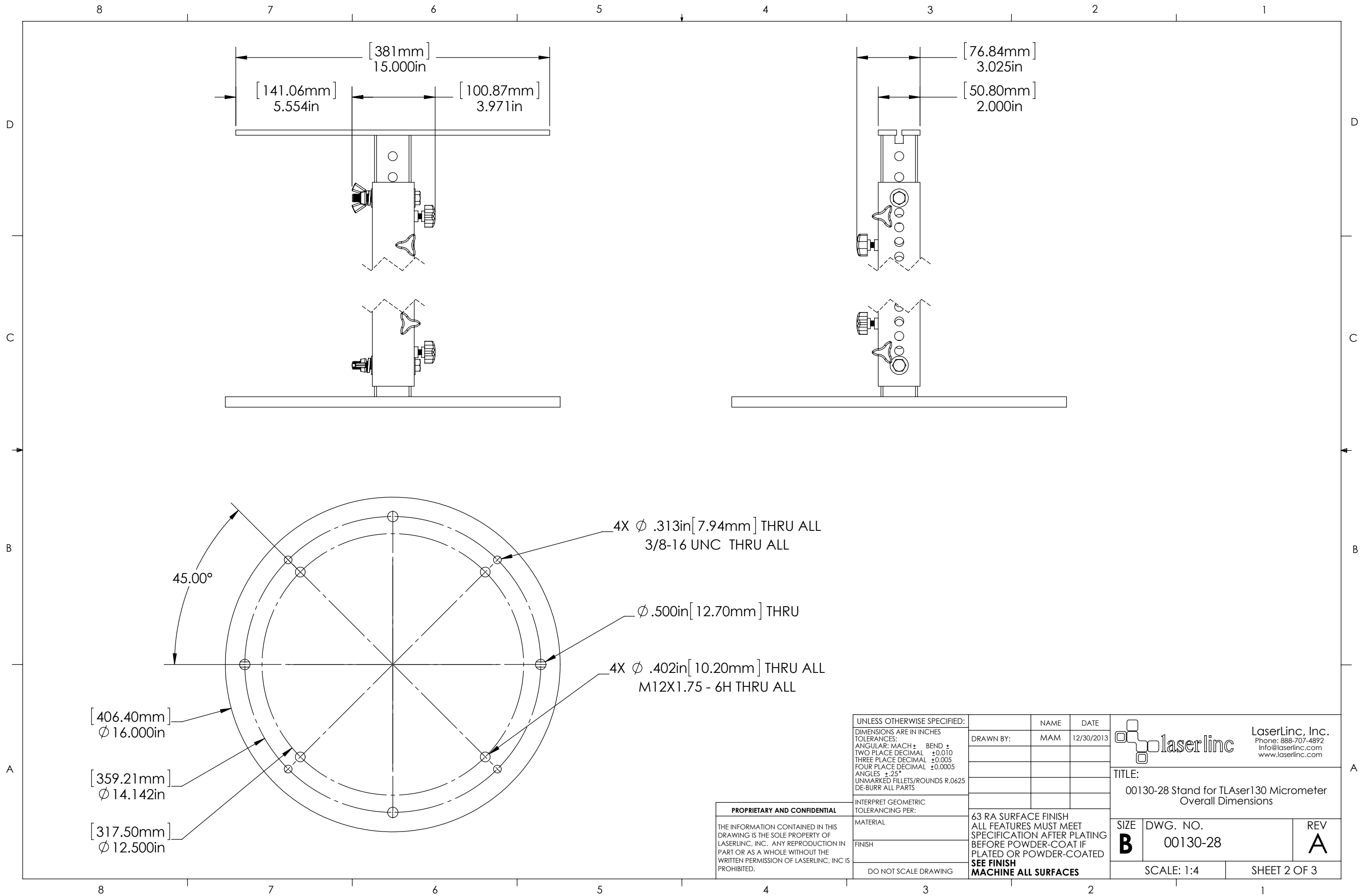

UNLESS OTHERWISE SPECIFIED:
 DIMENSIONS ARE IN INCHES
 TOLERANCES:
 ANGULAR: MACH \pm BEND \pm
 TWO PLACE DECIMAL ± 0.010
 THREE PLACE DECIMAL ± 0.005
 FOUR PLACE DECIMAL ± 0.0005
 ANGLES $\pm .25^\circ$
 UNMARKED FILLETS/ROUNDS R.0625
 DE-BURR ALL PARTS

NAME	DATE
DRAWN BY: MAM	12/30/2013

laserlinc LaserLinc, Inc.
 Phone: 888-707-4892
 Info@laserlinc.com
 www.laserlinc.com

TITLE:
 00130-28 Stand for TLaser130 Micrometer
 Overall Dimensions

PROPRIETARY AND CONFIDENTIAL
 THE INFORMATION CONTAINED IN THIS DRAWING IS THE SOLE PROPERTY OF LASERLINC, INC. ANY REPRODUCTION IN PART OR AS A WHOLE WITHOUT THE WRITTEN PERMISSION OF LASERLINC, INC IS PROHIBITED.

INTERPRET GEOMETRIC TOLERANCING PER:	63 RA SURFACE FINISH ALL FEATURES MUST MEET SPECIFICATION AFTER PLATING BEFORE POWDER-COAT IF PLATED OR POWDER-COATED SEE FINISH MACHINE ALL SURFACES
MATERIAL	
FINISH	
DO NOT SCALE DRAWING	

SIZE B	DWG. NO. 00130-28	REV A
SCALE: 1:4		SHEET 2 OF 3

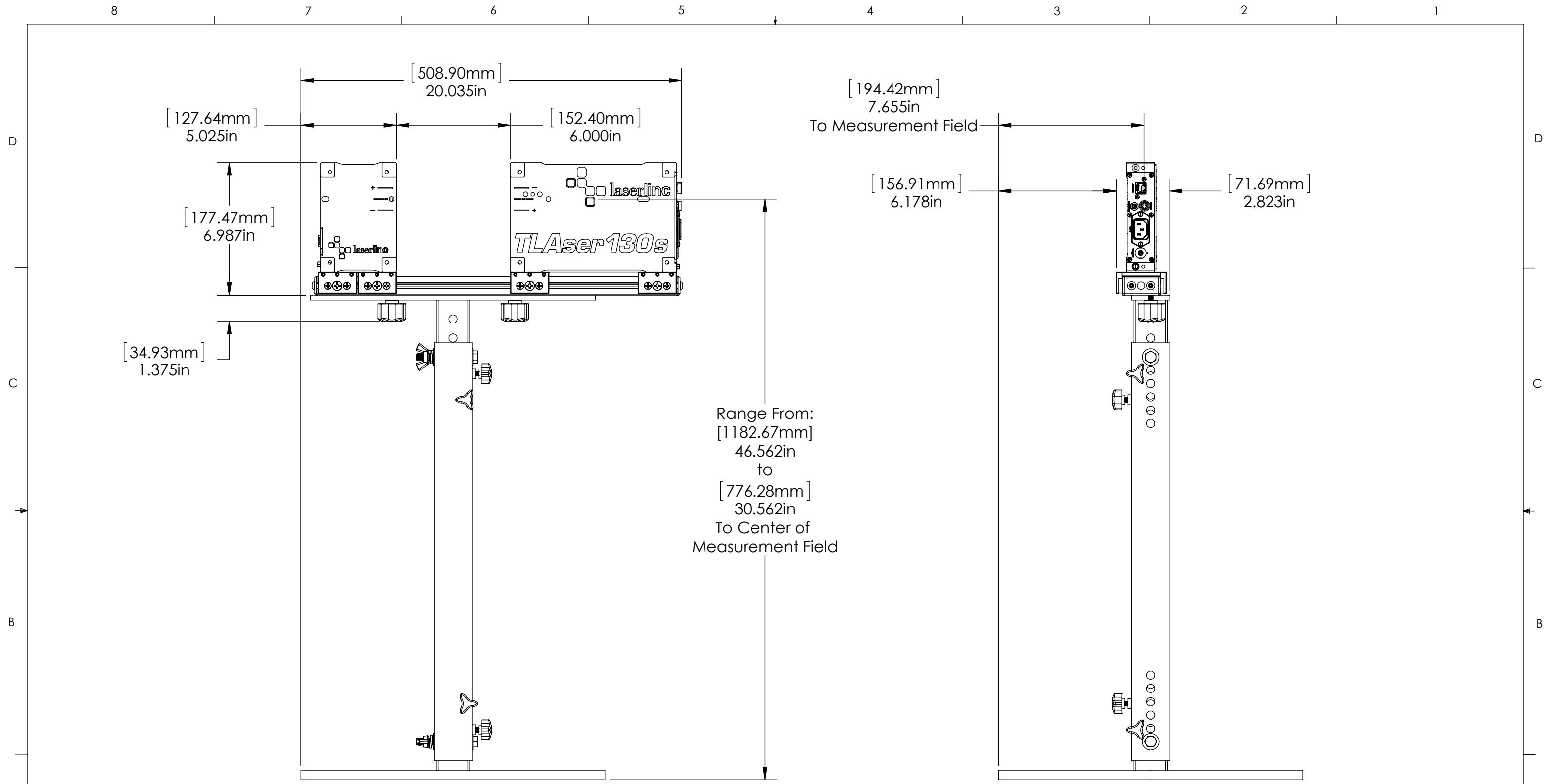

Range From:
 [1182.67mm]
 46.562in
 to
 [776.28mm]
 30.562in
 To Center of
 Measurement Field

UNLESS OTHERWISE SPECIFIED:
 DIMENSIONS ARE IN INCHES
 TOLERANCES:
 ANGULAR: MACH ± BEND ±
 TWO PLACE DECIMAL ±0.010
 THREE PLACE DECIMAL ±0.005
 FOUR PLACE DECIMAL ±0.0005
 ANGLES ±.25°
 UNMARKED FILLETS/ROUNDS R.0625
 DE-BURR ALL PARTS

NAME	DATE
MAM	12/30/2013
DRAWN BY:	

laserlinc LaserLinc, Inc.
 Phone: 888-707-4892
 Info@laserlinc.com
 www.laserlinc.com

TITLE:
 00130-28 Stand for TLAser130 Micrometer
 Overall Dimensions

PROPRIETARY AND CONFIDENTIAL
 THE INFORMATION CONTAINED IN THIS
 DRAWING IS THE SOLE PROPERTY OF
 LASERLINC, INC. ANY REPRODUCTION IN
 PART OR AS A WHOLE WITHOUT THE
 WRITTEN PERMISSION OF LASERLINC, INC IS
 PROHIBITED.

INTERPRET GEOMETRIC TOLERANCING PER:	63 RA SURFACE FINISH ALL FEATURES MUST MEET SPECIFICATION AFTER PLATING BEFORE POWDER-COAT IF PLATED OR POWDER-COATED SEE FINISH MACHINE ALL SURFACES
MATERIAL	
FINISH	
DO NOT SCALE DRAWING	

SIZE B	DWG. NO. 00130-28	REV A
SCALE: 1:5		SHEET 3 OF 3