

8

7

6

5

4

3

2

1

F

E

D

C

B

A

F

E

D

C

B

A

REVISIONS				
ZONE	REV.	DESCRIPTION	DATE	APPROVED
	A	Check-In	9/6/2013	MAM

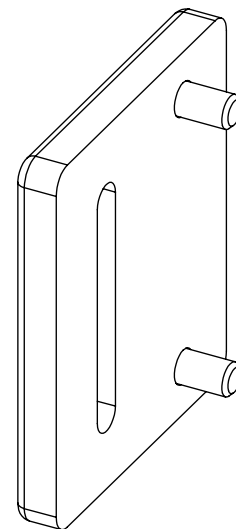
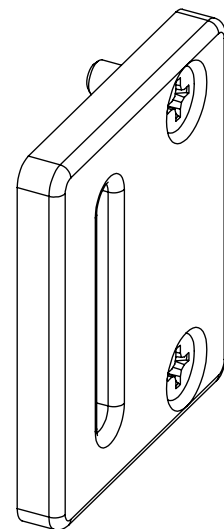

# TLASER 130 WINDOW GUARD OVERALLS

## INDEX

- (1) COVER PAGE
- (2) DIMENSIONS

<b>GENERAL FINISH NOTE</b> DE-BURR AND BREAK ALL SHARP EDGES BEFORE FINISH AND/OR SHIPPING	UNLESS OTHERWISE SPECIFIED: DIMENSIONS ARE IN INCHES TOLERANCES: ANGLES ±.25° TWO PLACE DECIMAL ±0.010 THREE PLACE DECIMAL ±0.005 FOUR PLACE DECIMAL ±0.0005 UNMARKED FILLETS/CHAMFER .06 DE-BURR ALL PARTS	NAME EMM	DATE 1/14/2021	 <b>LASERLINC, INC.</b> PHONE: 888-707-4892 INFO@LASERLINC.COM WWW.LASERLINC.COM
	PROPRIETARY AND CONFIDENTIAL	INTERPRET GEOMETRIC TOLERANCING PER: ASME Y14.5	TITLE: 0130-0000-31 TLASER130 WINDOW GUARD OVERALLS	
THE INFORMATION CONTAINED IN THIS DRAWING IS THE SOLE PROPERTY OF LASERLINC, INC. ANY REPRODUCTION IN PART OR AS A WHOLE WITHOUT THE WRITTEN PERMISSION OF LASERLINC, INC. IS PROHIBITED.	MATERIAL	63 RA SURFACE FINISH ALL FEATURES MUST MEET SPECIFICATION AFTER PLATING BEFORE POWDER-COAT IF PLATED OR POWDER-COATED SEE FINISH		SIZE <b>B</b>
	FINISH	DWG. NO. 0130-0000-31		REV <b>A</b>
	DO NOT SCALE DRAWING	SCALE: 1:1		SHEET 1 OF 2

8

7

6

5

4

3

2

1

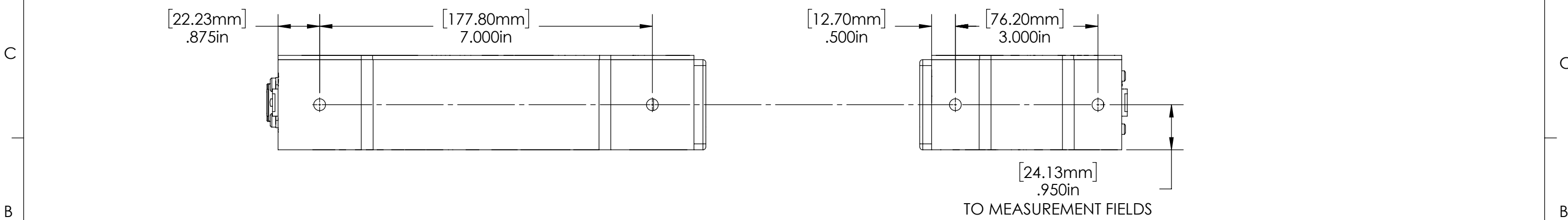
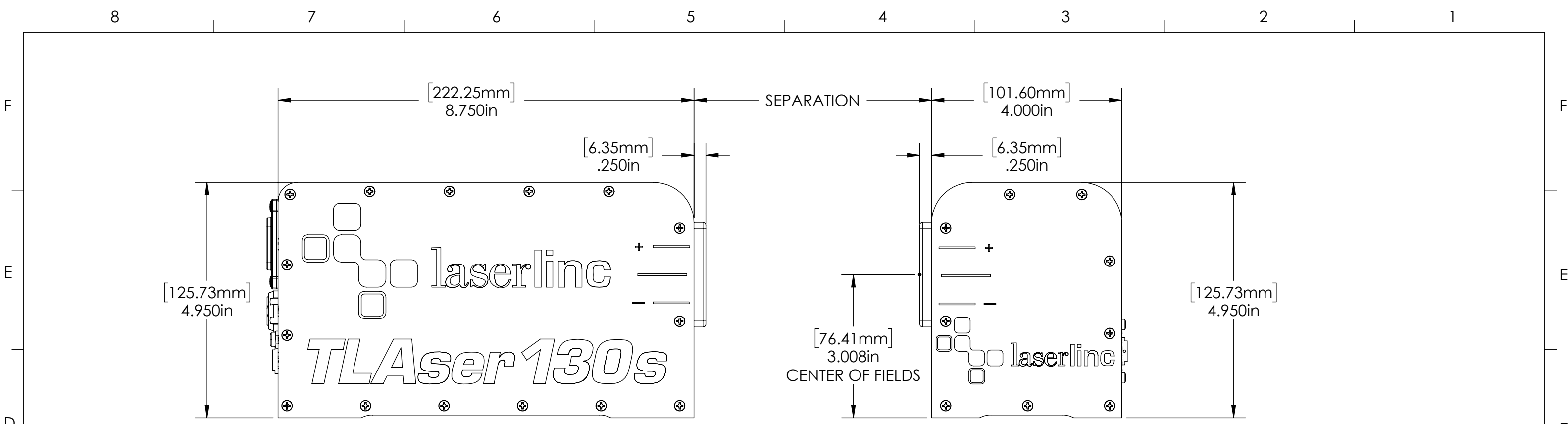

<b>GENERAL FINISH NOTE</b> DE-BURR AND BREAK ALL SHARP EDGES BEFORE FINISH AND/OR SHIPPING  PROPRIETARY AND CONFIDENTIAL  THE INFORMATION CONTAINED IN THIS DRAWING IS THE SOLE PROPERTY OF LASERLINC, INC. ANY REPRODUCTION IN PART OR AS A WHOLE WITHOUT THE WRITTEN PERMISSION OF LASERLINC, INC. IS PROHIBITED.	UNLESS OTHERWISE SPECIFIED: DIMENSIONS ARE IN INCHES TOLERANCES: ANGLES ±.25 TWO PLACE DECIMAL ±0.010 THREE PLACE DECIMAL ±0.005 FOUR PLACE DECIMAL ±0.0005 UNMARKED FILLETS/CHAMFER .06 DE-BURR ALL PARTS	NAME DATE DRAWN BY: EMM 1/14/2021	 <b>LASERLINC, INC.</b> PHONE: 888-707-4892 INFO@LASERLINC.COM WWW.LASERLINC.COM		
	INTERPRET GEOMETRIC TOLERANCING PER: ASME Y14.5	TITLE: 0130-0000-31 TLASER130 WINDOW GUARD OVERALLS			
	MATERIAL FINISH DO NOT SCALE DRAWING	63 RA SURFACE FINISH ALL FEATURES MUST MEET SPECIFICATION AFTER PLATING BEFORE POWDER-COAT IF PLATED OR POWDER-COATED SEE FINISH	SIZE <b>B</b>	DWG. NO. 0130-0000-31	REV <b>A</b>
			SCALE: 1:2	SHEET 2 OF 2	