

8

7

6

5

4

3

2

1

REVISIONS				
ZONE	REV.	DESCRIPTION	DATE	APPROVED
	A	Check-In	3/3/2015	MAM

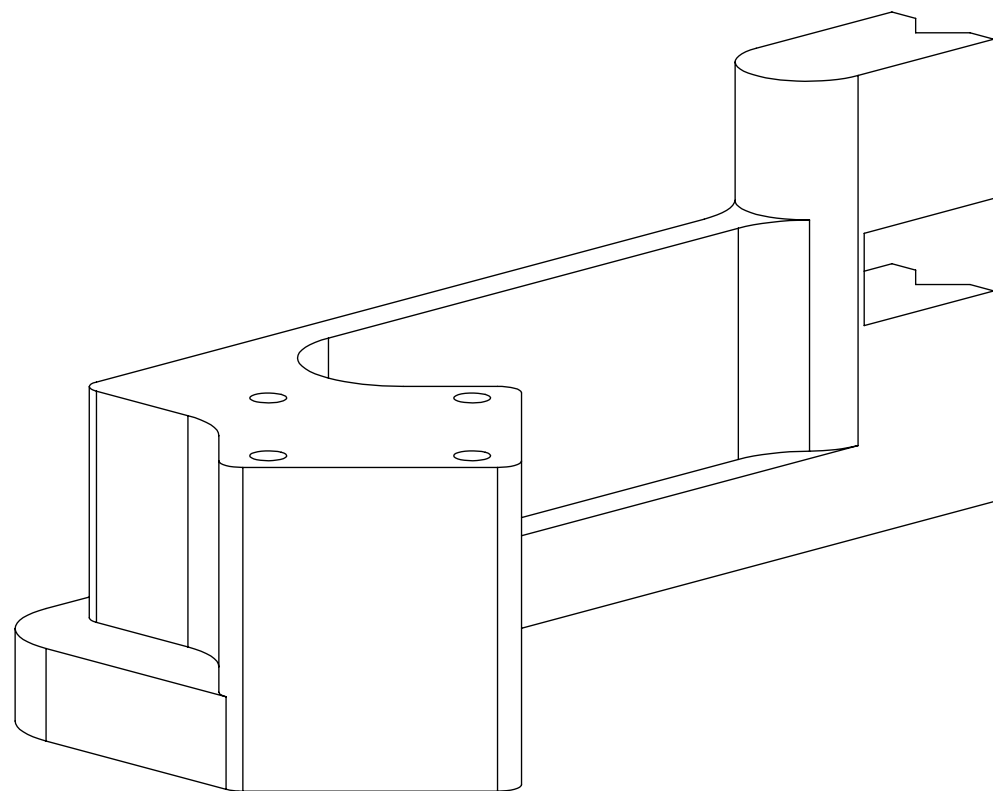

TLaser203 Calibration Fixture Pin Holder Overall Dimensions

INDEX

- (1) Cover Page
- (2) Dimensions

GENERAL FINISH NOTE		UNLESS OTHERWISE SPECIFIED:		NAME	DATE	 LaserLinc, Inc. Phone: 888-707-4892 Info@laserlinc.com www.laserlinc.com
DE-BURR AND BREAK ALL SHARP EDGES BEFORE FINISH AND/OR SHIPPING		DIMENSIONS ARE IN INCHES TOLERANCES: ANGULAR: MACH ± BEND ± TWO PLACE DECIMAL ±0.010 THREE PLACE DECIMAL ±0.005 FOUR PLACE DECIMAL ±0.0005 ANGLES ±.25° UNMARKED FILLETS/ROUNDS R.0625 DE-BURR ALL PARTS		DRAWN BY:	MAM	
PROPRIETARY AND CONFIDENTIAL		INTERPRET GEOMETRIC TOLERANCING PER:				
THE INFORMATION CONTAINED IN THIS DRAWING IS THE SOLE PROPERTY OF LASERLINC, INC. ANY REPRODUCTION IN PART OR AS A WHOLE WITHOUT THE WRITTEN PERMISSION OF LASERLINC, INC IS PROHIBITED.		MATERIAL 6061 Aluminum		63 RA SURFACE FINISH ALL FEATURES MUST MEET SPECIFICATION AFTER PLATING BEFORE POWDER-COAT IF PLATED OR POWDER-COATED SEE FINISH MACHINE ALL SURFACES		TITLE: 00203-51 TLaser203 Calibration Fixture Pin Holder Overall Dimensions
		FINISH Black Anodize		SIZE	DWG. NO.	REV
		DO NOT SCALE DRAWING		B	00203-51	A
				SCALE: 2:1		SHEET 1 OF 2

8

7

6

5

4

3

2

1

F

E

D

C

B

A

F

E

D

C

B

A

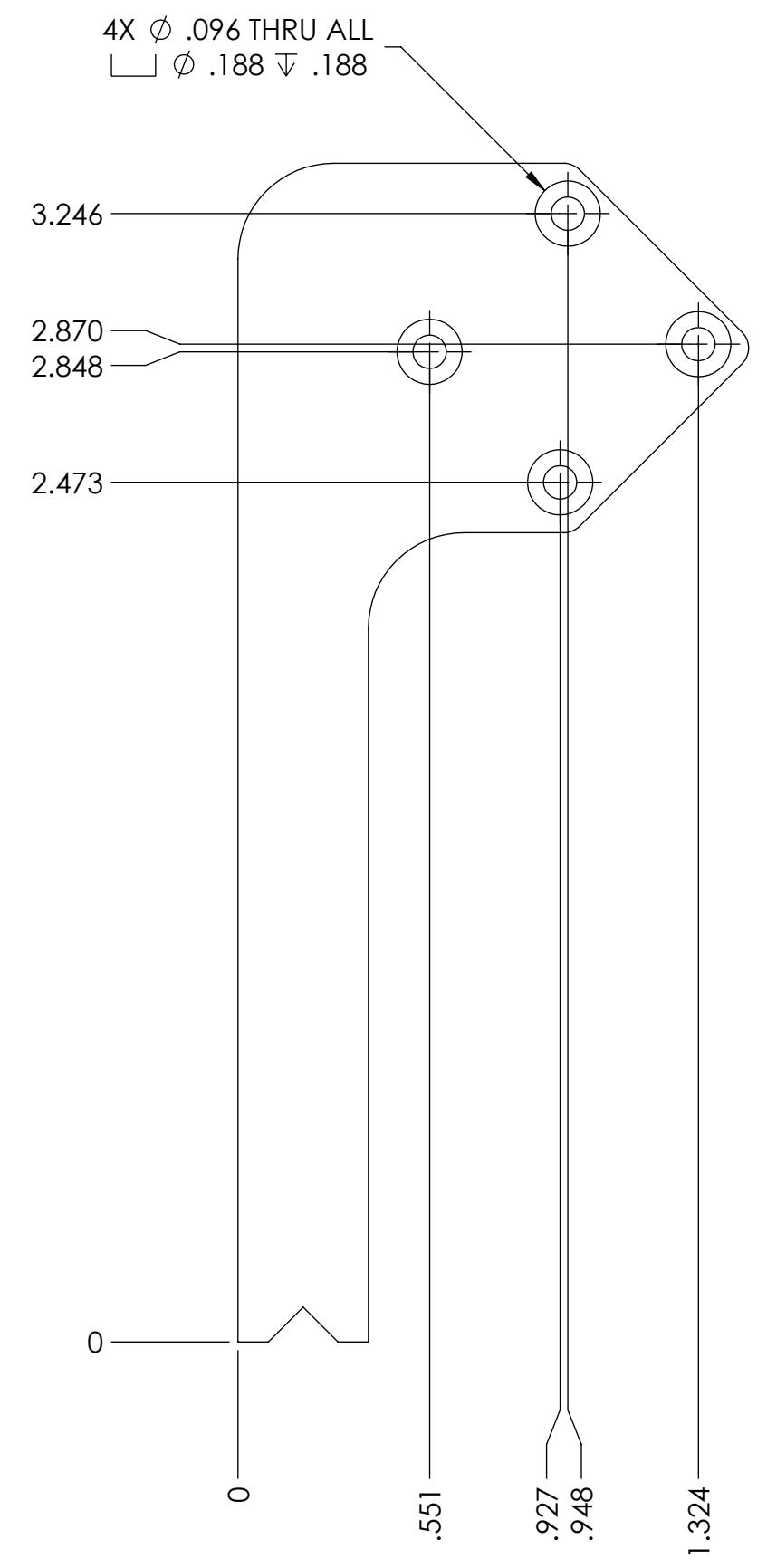
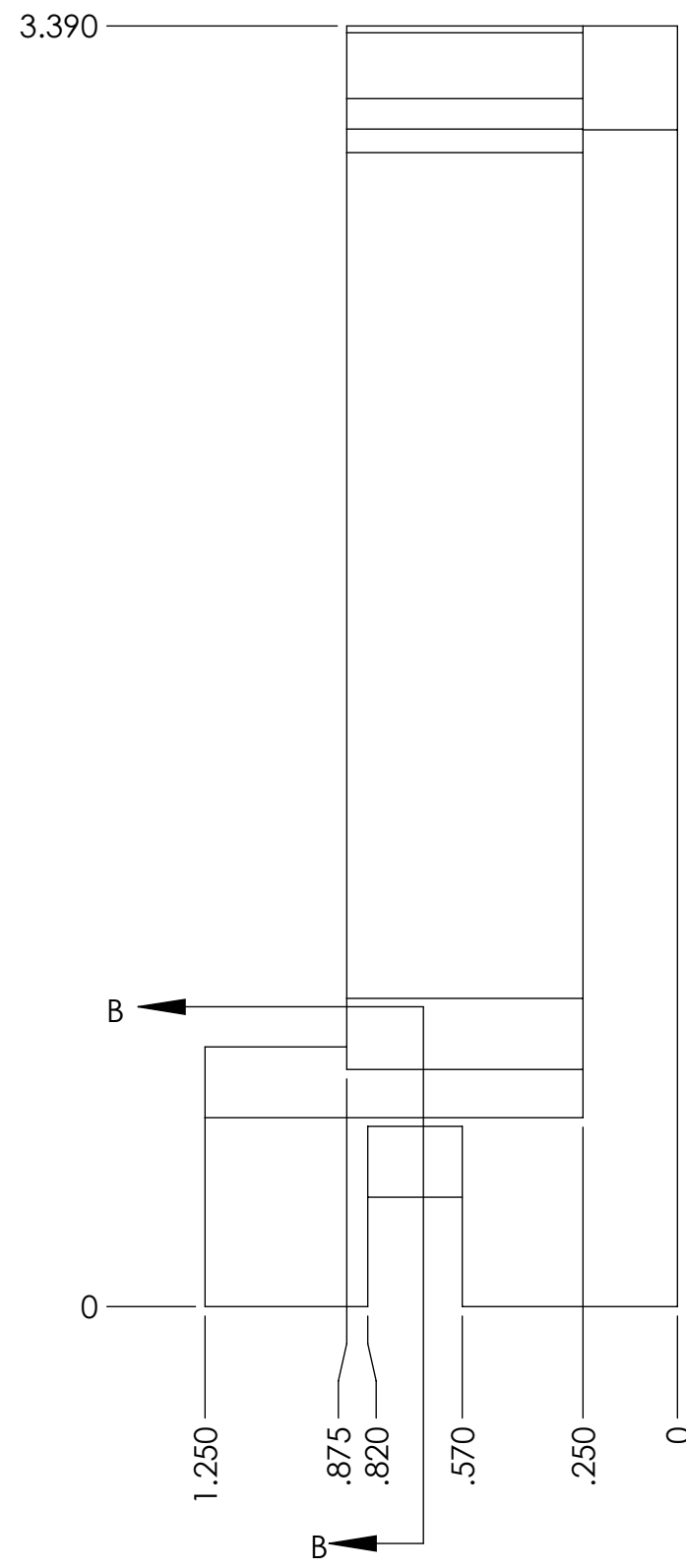
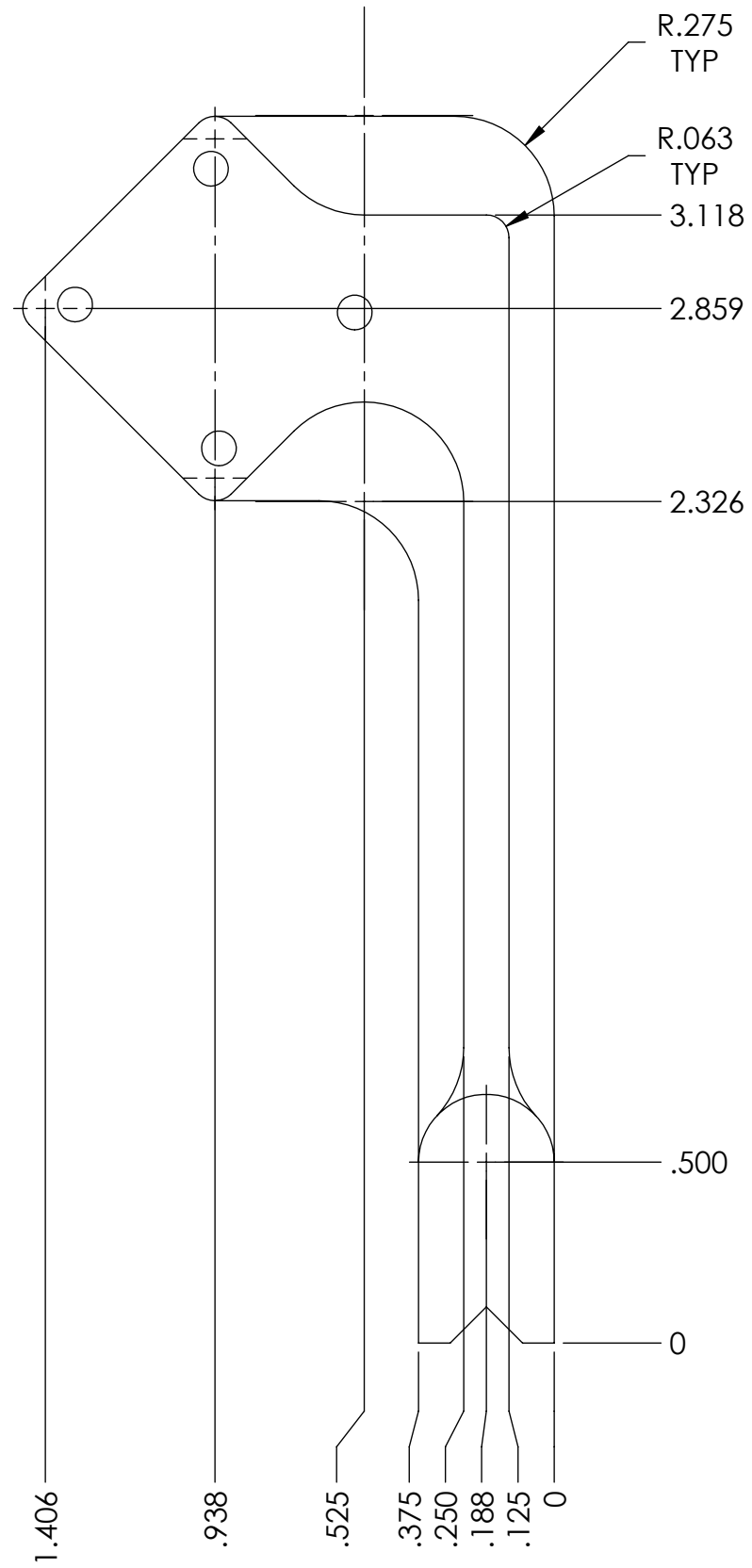

SECTION B-B
SCALE 4 : 1

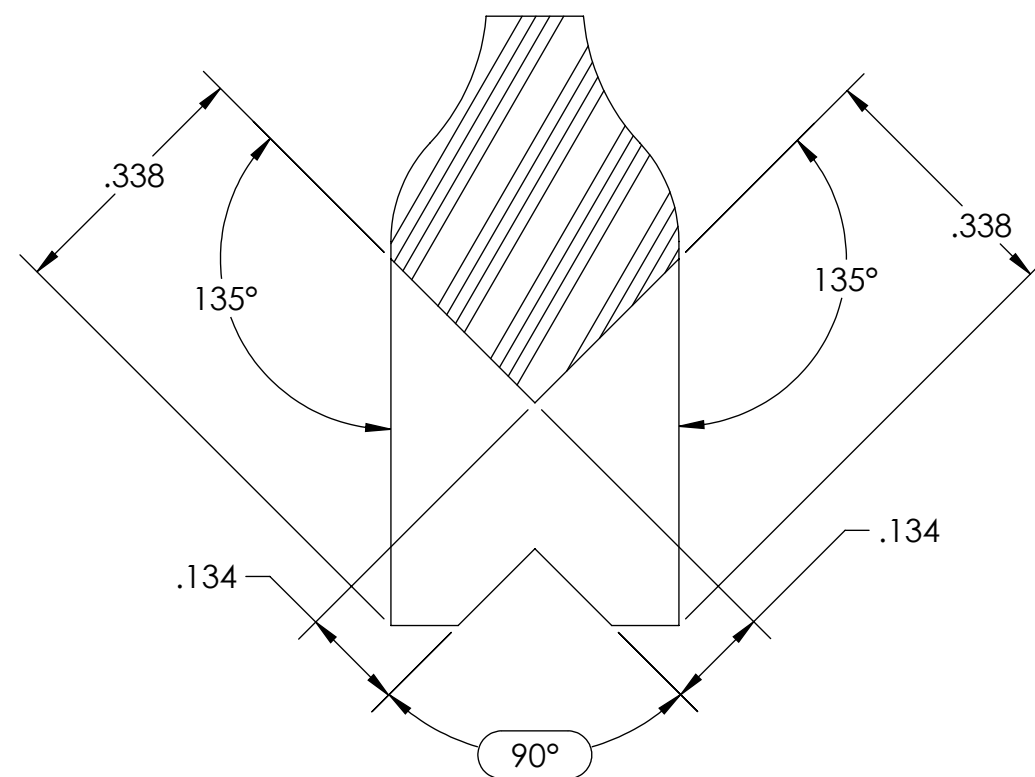

GENERAL FINISH NOTE DE-BURR AND BREAK ALL SHARP EDGES BEFORE FINISH AND/OR SHIPPING	UNLESS OTHERWISE SPECIFIED: DIMENSIONS ARE IN INCHES TOLERANCES: ANGULAR: MACH ± BEND ± TWO PLACE DECIMAL: ±0.010 THREE PLACE DECIMAL: ±0.005 FOUR PLACE DECIMAL: ±0.0005 ANGLES: ±.25° UNMARKED FILLETS/ROUNDS R.0625 DE-BURR ALL PARTS	NAME MAM	DATE 3/3/2015	LaserLinc, Inc. Phone: 888-707-4892 Info@laserlinc.com www.laserlinc.com
	PROPRIETARY AND CONFIDENTIAL THE INFORMATION CONTAINED IN THIS DRAWING IS THE SOLE PROPERTY OF LASERLINC, INC. ANY REPRODUCTION IN PART OR AS A WHOLE WITHOUT THE WRITTEN PERMISSION OF LASERLINC, INC IS PROHIBITED.	INTERPRET GEOMETRIC TOLERANCING PER: MATERIAL 6061 Aluminum FINISH Black Anodize DO NOT SCALE DRAWING	DRAWN BY: MAM	
63 RA SURFACE FINISH ALL FEATURES MUST MEET SPECIFICATION AFTER PLATING BEFORE POWDER-COAT IF PLATED OR POWDER-COATED SEE FINISH MACHINE ALL SURFACES	SIZE C	DWG. NO. 00203-51	REV A	SCALE: 2:1 SHEET 2 OF 2