

8 7 6 5 4 3 2 1

REVISIONS				
ZONE	REV.	DESCRIPTION	DATE	APPROVED
	A	Check-In	1/7/2013	MAM

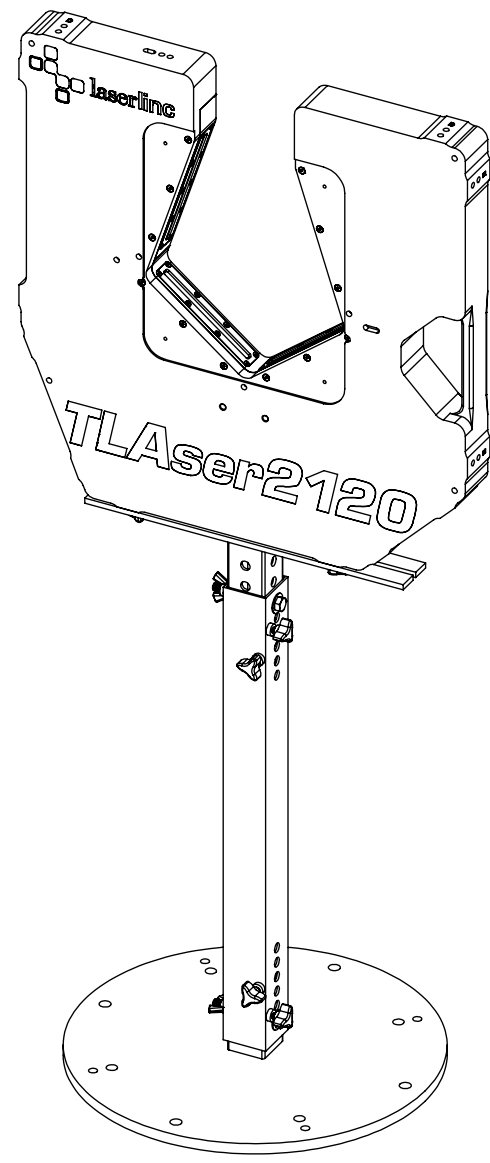

Stand for TLaser2120 Overall Dimensions

INDEX

- (1) Cover Page
- (2) Fixture Dimensions
- (3) Mounted Dimensions

UNLESS OTHERWISE SPECIFIED:		NAME	DATE	 LaserLinc, Inc. Phone: 888-707-4892 Info@laserlinc.com www.laserlinc.com
DIMENSIONS ARE IN INCHES TOLERANCES: ANGULAR: MACH ± BEND ± TWO PLACE DECIMAL ±0.010 THREE PLACE DECIMAL ±0.005 FOUR PLACE DECIMAL ±0.0005 ANGLES ±.25° UNMARKED FILLETS/ROUNDS R.0625 DE-BURR ALL PARTS		DRAWN BY:	MAM	
INTERPRET GEOMETRIC TOLERANCING PER:		63 RA SURFACE FINISH ALL FEATURES MUST MEET SPECIFICATION AFTER PLATING BEFORE POWDER-COAT IF PLATED OR POWDER-COATED SEE FINISH MACHINE ALL SURFACES		
PROPRIETARY AND CONFIDENTIAL THE INFORMATION CONTAINED IN THIS DRAWING IS THE SOLE PROPERTY OF LASERLINC, INC. ANY REPRODUCTION IN PART OR AS A WHOLE WITHOUT THE WRITTEN PERMISSION OF LASERLINC, INC IS PROHIBITED.		MATERIAL	TITLE: 02120-28 Stand for TLaser2120 Overall Dimensions	
DO NOT SCALE DRAWING		FINISH	SIZE B	DWG. NO. 02120-28
			SCALE: 1:8	REV A SHEET 1 OF 3

8 7 6 5 4 3 2 1

8 7 6 5 4 3 2 1

D

D

C

C

B

B

A

A

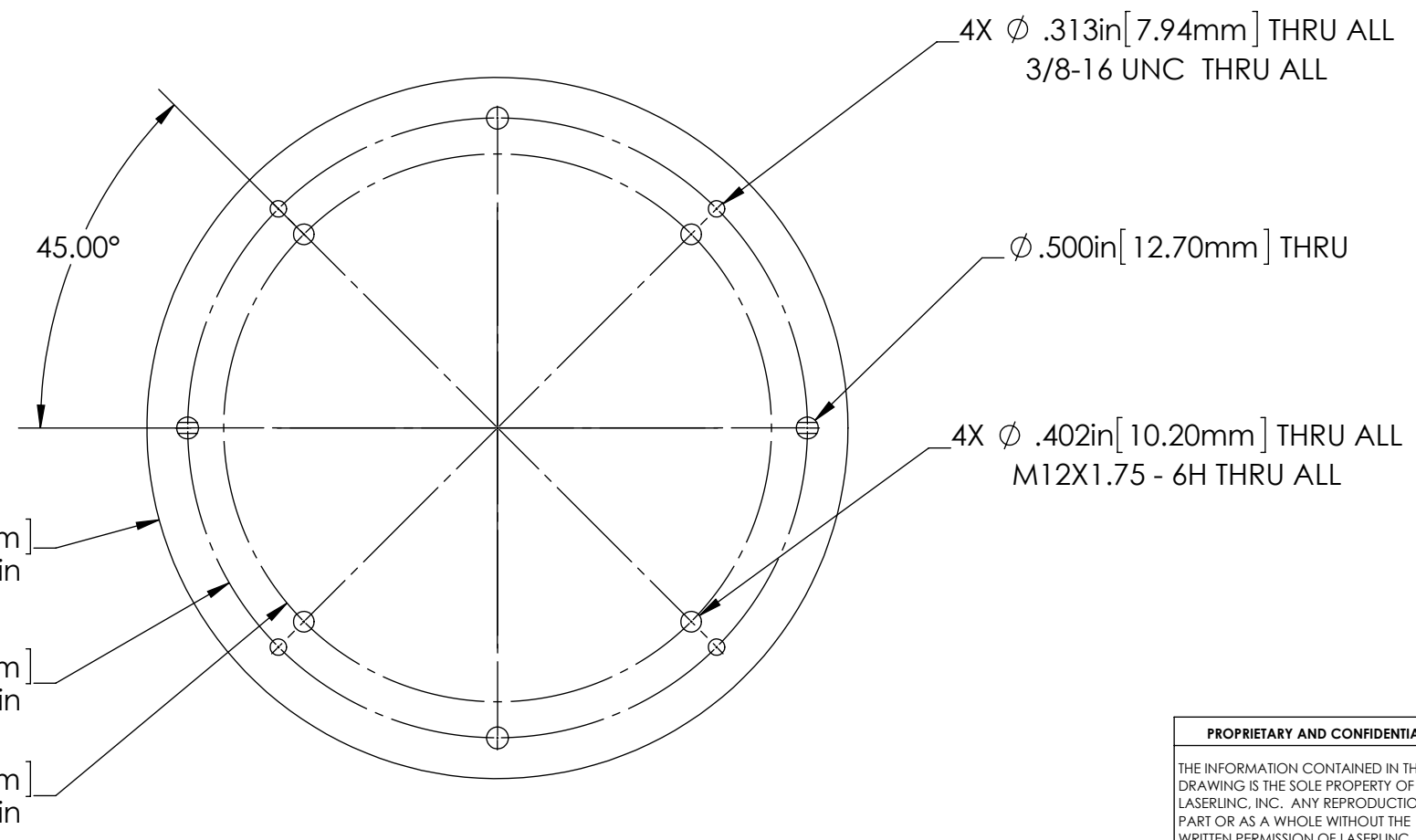
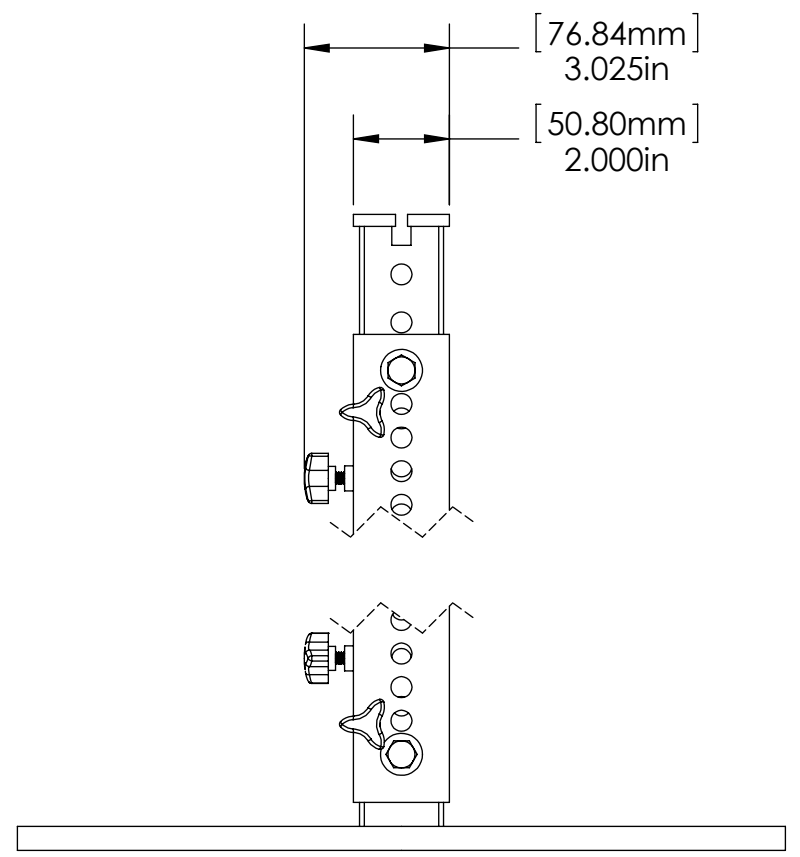
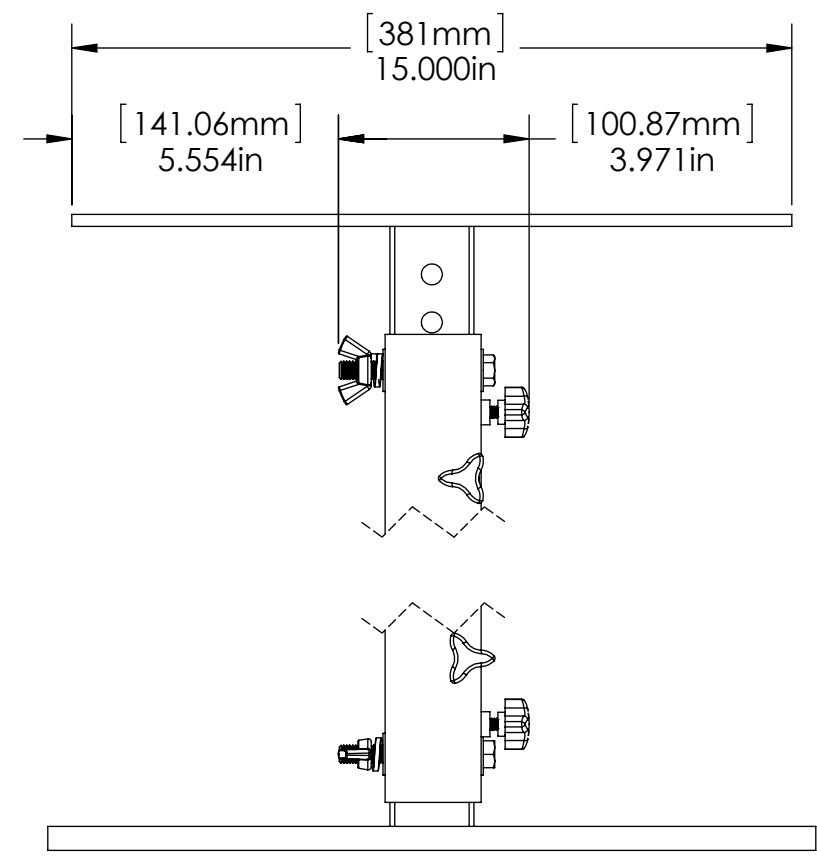

UNLESS OTHERWISE SPECIFIED:
 DIMENSIONS ARE IN INCHES
 TOLERANCES:
 ANGULAR: MACH ± BEND ±
 TWO PLACE DECIMAL ±0.010
 THREE PLACE DECIMAL ±0.005
 FOUR PLACE DECIMAL ±0.0005
 ANGLES ±.25°
 UNMARKED FILLETS/ROUNDS R.0625
 DE-BURR ALL PARTS

	NAME	DATE
DRAWN BY:	MAM	1/7/2013

laserlinc LaserLinc, Inc.
 Phone: 888-707-4892
 Info@laserlinc.com
 www.laserlinc.com

TITLE:
 02120-28 Stand for TLaser2120 Overall Dimensions

PROPRIETARY AND CONFIDENTIAL
 THE INFORMATION CONTAINED IN THIS DRAWING IS THE SOLE PROPERTY OF LASERLINC, INC. ANY REPRODUCTION IN PART OR AS A WHOLE WITHOUT THE WRITTEN PERMISSION OF LASERLINC, INC IS PROHIBITED.

INTERPRET GEOMETRIC TOLERANCING PER:
MATERIAL
FINISH
DO NOT SCALE DRAWING

63 RA SURFACE FINISH
 ALL FEATURES MUST MEET SPECIFICATION AFTER PLATING BEFORE POWDER-COAT IF PLATED OR POWDER-COATED
SEE FINISH MACHINE ALL SURFACES

SIZE B	DWG. NO. 02120-28	REV A
SCALE: 1:4		SHEET 2 OF 3

8 7 6 5 4 3 2 1

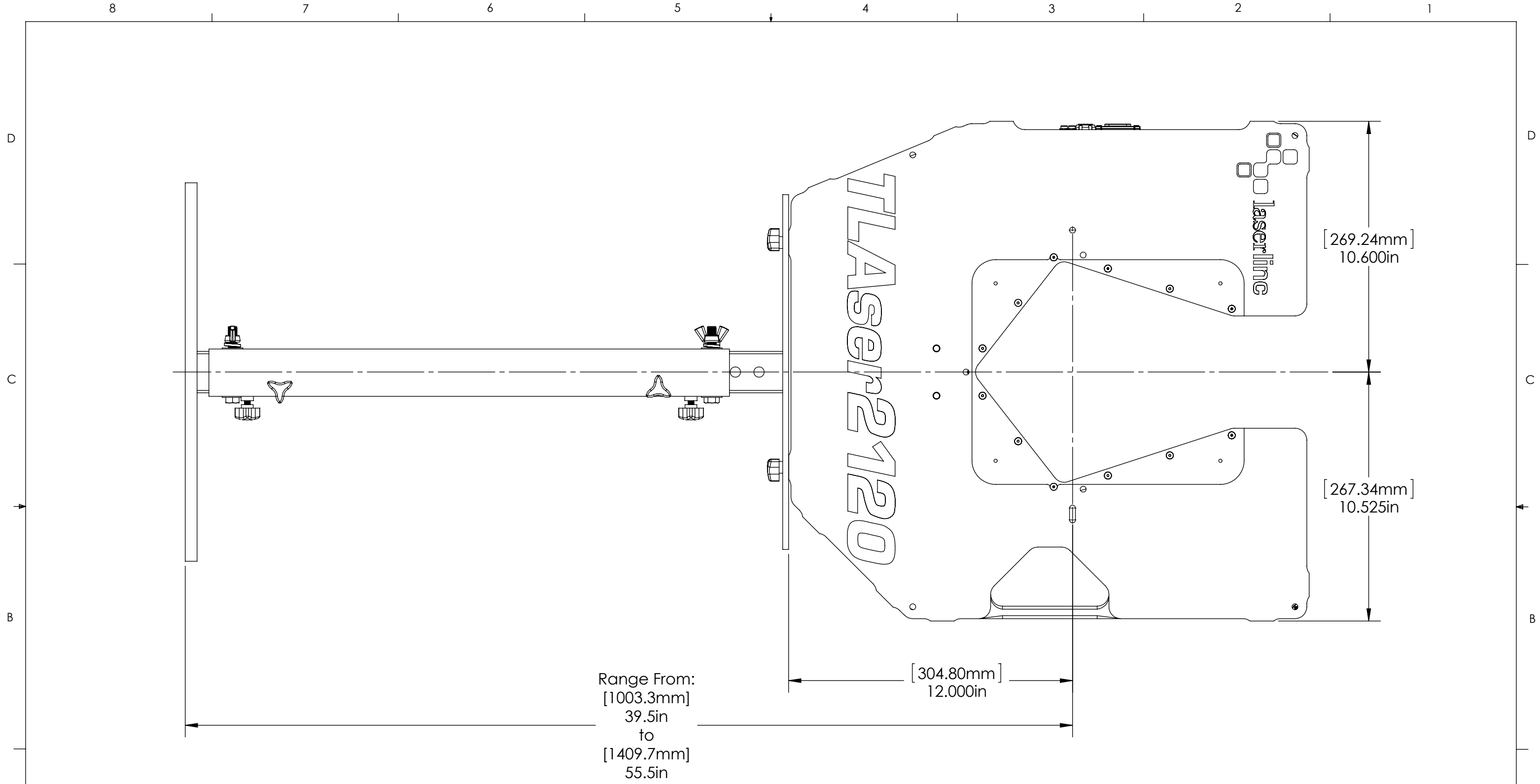

UNLESS OTHERWISE SPECIFIED:
DIMENSIONS ARE IN INCHES
TOLERANCES:
ANGULAR: MACH ± BEND ±
TWO PLACE DECIMAL ±0.010
THREE PLACE DECIMAL ±0.005
FOUR PLACE DECIMAL ±0.0005
ANGLES ±.25°
UNMARKED FILLETS/ROUNDS R.0625
DE-BURR ALL PARTS

DRAWN BY:	NAME	DATE
MAM		1/7/2013

laserlinc LaserLinc, Inc.
Phone: 888-707-4892
Info@laserlinc.com
www.laserlinc.com

TITLE:
02120-28 Stand for TLAsEr2120 Overall
Dimensions

PROPRIETARY AND CONFIDENTIAL
THE INFORMATION CONTAINED IN THIS
DRAWING IS THE SOLE PROPERTY OF
LASERLINC, INC. ANY REPRODUCTION IN
PART OR AS A WHOLE WITHOUT THE
WRITTEN PERMISSION OF LASERLINC, INC IS
PROHIBITED.

INTERPRET GEOMETRIC
TOLERANCING PER:
MATERIAL
FINISH
DO NOT SCALE DRAWING

63 RA SURFACE FINISH
ALL FEATURES MUST MEET
SPECIFICATION AFTER PLATING
BEFORE POWDER-COAT IF
PLATED OR POWDER-COATED
**SEE FINISH
MACHINE ALL SURFACES**

SIZE	DWG. NO.	REV
B	02120-28	A
SCALE: 1:4		SHEET 3 OF 3