

8 7 6 5 4 3 2 1

REVISIONS				
ZONE	REV.	DESCRIPTION	DATE	APPROVED
	A	Check-In	6/11/2013	MAM

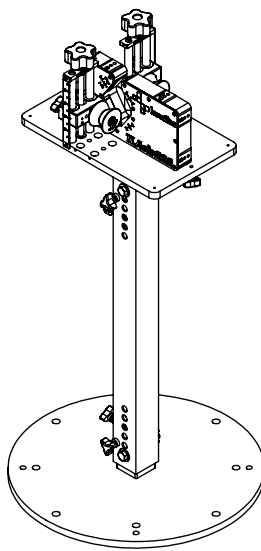

# TLAser222 Mounted to Plate Roller Guide & Stand

## INDEX

- (1) Cover Page
- (2) Dimensions

UNLESS OTHERWISE SPECIFIED:		NAME	DATE	 <b>LaserLinc, Inc.</b> Phone: 888-707-4892 Info@laserlinc.com www.laserlinc.com
DIMENSIONS ARE IN INCHES TOLERANCES: ANGULAR: MACH ± BEND ± TWO PLACE DECIMAL ±0.010 THREE PLACE DECIMAL ±0.005 FOUR PLACE DECIMAL ±0.0005 ANGLES ±.25° UNMARKED FILLETS/ROUNDS R.0625 DE-BURR ALL PARTS		DRAWN BY:	MAM 6/11/2013	
INTERPRET GEOMETRIC TOLERANCING PER:				TITLE:
<b>PROPRIETARY AND CONFIDENTIAL</b> THE INFORMATION CONTAINED IN THIS DRAWING IS THE SOLE PROPERTY OF LASERLINC, INC. ANY REPRODUCTION IN PART OR AS A WHOLE WITHOUT THE WRITTEN PERMISSION OF LASERLINC, INC IS PROHIBITED.		63 RA SURFACE FINISH ALL FEATURES MUST MEET SPECIFICATION AFTER PLATING BEFORE POWDER-COAT IF PLATED OR POWDER-COATED <b>SEE FINISH MACHINE ALL SURFACES</b>		00222-01 Mounted to 00222-62 and 00222-28
DO NOT SCALE DRAWING		SIZE	DWG. NO.	REV
		<b>B</b>	00222-01, 00222-28, 00222-62	<b>A</b>
		SCALE: 1:12		SHEET 1 OF 2

8 7 6 5 4 3 2 1

D  
C  
B  
A

D  
C  
B  
A

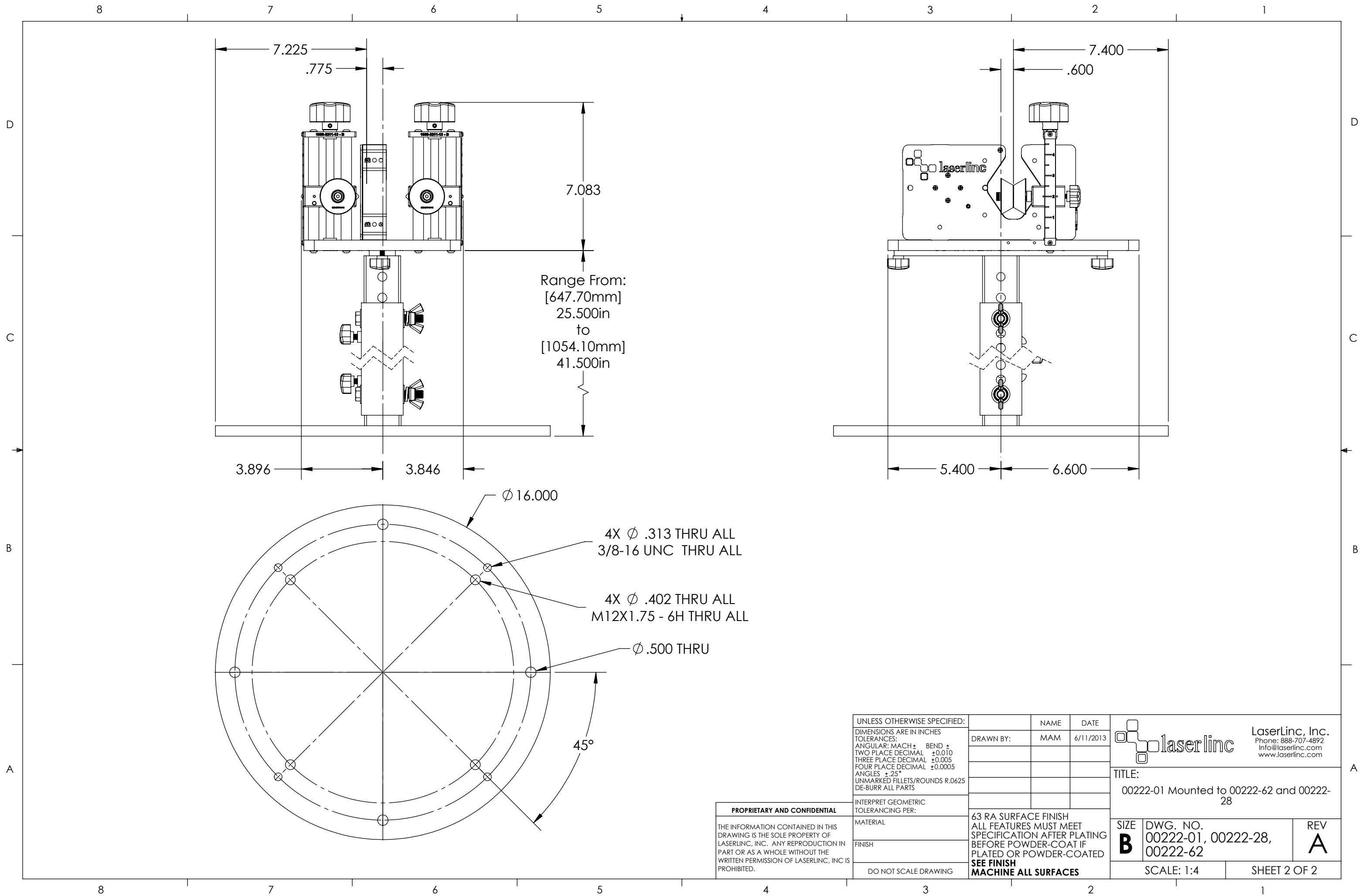

UNLESS OTHERWISE SPECIFIED:  
 DIMENSIONS ARE IN INCHES  
 TOLERANCES:  
 ANGULAR: MACH  $\pm$  BEND  $\pm$   
 TWO PLACE DECIMAL  $\pm 0.010$   
 THREE PLACE DECIMAL  $\pm 0.005$   
 FOUR PLACE DECIMAL  $\pm 0.0005$   
 ANGLES  $\pm .25^\circ$   
 UNMARKED FILLETS/ROUNDS R.0625  
 DE-BURR ALL PARTS

NAME	DATE
MAM	6/11/2013
DRAWN BY:	

**laserline** LaserLinc, Inc.  
 Phone: 888-707-4892  
 Info@laserlinc.com  
 www.laserlinc.com

TITLE:  
 00222-01 Mounted to 00222-62 and 00222-28

**PROPRIETARY AND CONFIDENTIAL**  
 THE INFORMATION CONTAINED IN THIS DRAWING IS THE SOLE PROPERTY OF LASERLINC, INC. ANY REPRODUCTION IN PART OR AS A WHOLE WITHOUT THE WRITTEN PERMISSION OF LASERLINC, INC IS PROHIBITED.

MATERIAL	63 RA SURFACE FINISH ALL FEATURES MUST MEET SPECIFICATION AFTER PLATING BEFORE POWDER-COAT IF PLATED OR POWDER-COATED <b>SEE FINISH MACHINE ALL SURFACES</b>
FINISH	

SIZE <b>B</b>	DWG. NO. 00222-01, 00222-28, 00222-62	REV <b>A</b>
SCALE: 1:4		SHEET 2 OF 2