

8 7 6 5 4 3 2 1

REVISIONS				
ZONE	REV.	DESCRIPTION	DATE	APPROVED
	A	CHECK-IN	12/2/2020	TRA

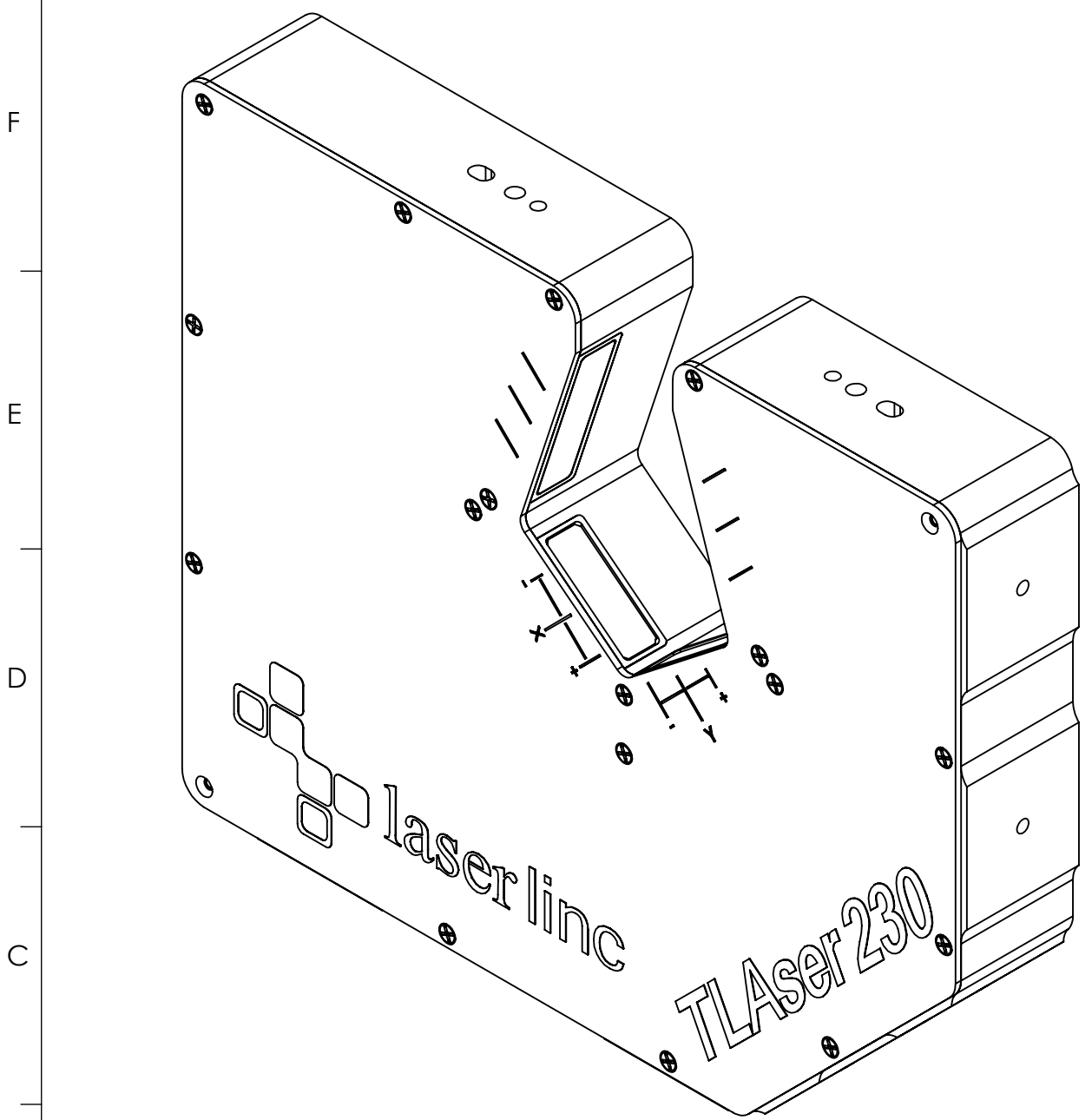

TLaser230, Dual-Axis Micrometer

F
E
D
C
B
A

F
E
D
C
B
A

- INDEX**
- (1) COVER PAGE
 - (2) OVERALL DIMENSIONS
 - (3) MOUNTING DIMENSION

GENERAL FINISH NOTE DE-BURR AND BREAK ALL SHARP EDGES BEFORE FINISH AND/OR SHIPPING	UNLESS OTHERWISE SPECIFIED: DIMENSIONS ARE IN INCHES TOLERANCES: ANGLES ±.25° TWO PLACE DECIMAL ±0.010 THREE PLACE DECIMAL ±0.005 FOUR PLACE DECIMAL ±0.0005 UNMARKED FILLETS/CHAMFER .06 DE-BURR ALL PARTS	NAME MAM	DATE 6/17/2020	 LASERLINC, INC. PHONE: 888-707-4892 INFO@LASERLINC.COM WWW.LASERLINC.COM
	INTERPRET GEOMETRIC TOLERANCING PER: ASME Y14.5	DRAWN BY:	TITLE: 0230-0000-00 230 MOUNTING DIMENSIONS	
PROPRIETARY AND CONFIDENTIAL THE INFORMATION CONTAINED IN THIS DRAWING IS THE SOLE PROPERTY OF LASERLINC, INC. ANY REPRODUCTION IN PART OR AS A WHOLE WITHOUT THE WRITTEN PERMISSION OF LASERLINC, INC. IS PROHIBITED.	MATERIAL STAINLESS STEEL	63 RA SURFACE FINISH ALL FEATURES MUST MEET SPECIFICATION AFTER PLATING BEFORE POWDER-COAT IF PLATED OR POWDER-COATED SEE FINISH		SIZE B
FINISH SEE NOTE	DO NOT SCALE DRAWING	DWG. NO. 0230-0000-00	REV A	SCALE: 1:2 SHEET 1 OF 3

8 7 6 5 4 3 2 1

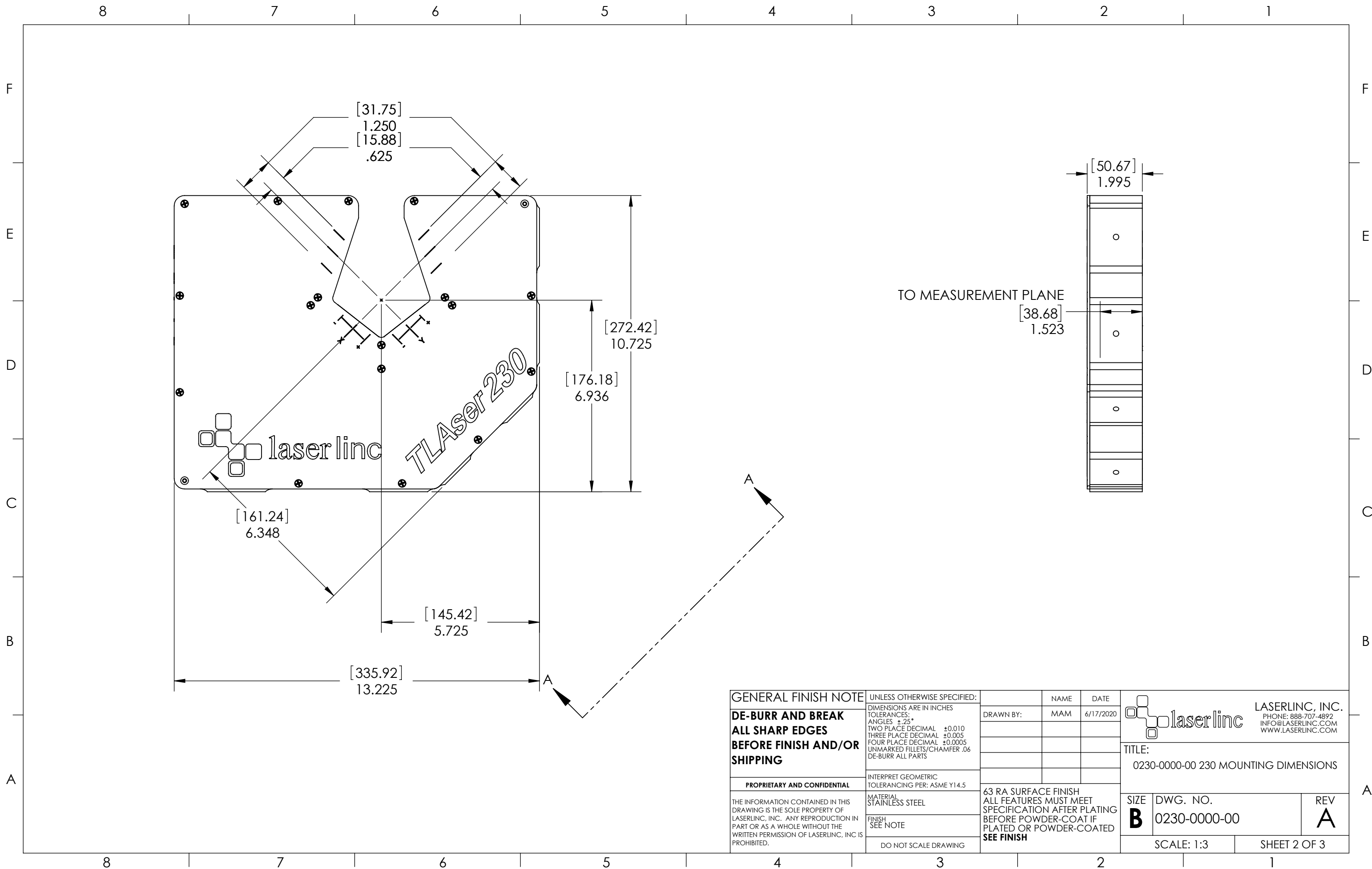

GENERAL FINISH NOTE		UNLESS OTHERWISE SPECIFIED:		NAME	DATE
DE-BURR AND BREAK ALL SHARP EDGES BEFORE FINISH AND/OR SHIPPING		DIMENSIONS ARE IN INCHES TOLERANCES: ANGLES ±.25° TWO PLACE DECIMAL ±0.010 THREE PLACE DECIMAL ±0.005 FOUR PLACE DECIMAL ±0.0005 UNMARKED FILLETS/CHAMFER .06 DE-BURR ALL PARTS		DRAWN BY:	MAM 6/17/2020
PROPRIETARY AND CONFIDENTIAL		INTERPRET GEOMETRIC TOLERANCING PER: ASME Y14.5			
THE INFORMATION CONTAINED IN THIS DRAWING IS THE SOLE PROPERTY OF LASERLINC, INC. ANY REPRODUCTION IN PART OR AS A WHOLE WITHOUT THE WRITTEN PERMISSION OF LASERLINC, INC. IS PROHIBITED.		MATERIAL STAINLESS STEEL		63 RA SURFACE FINISH ALL FEATURES MUST MEET SPECIFICATION AFTER PLATING BEFORE POWDER-COAT IF PLATED OR POWDER-COATED SEE FINISH	
		FINISH SEE NOTE		TITLE: 0230-0000-00 230 MOUNTING DIMENSIONS	
		DO NOT SCALE DRAWING		SIZE B	DWG. NO. 0230-0000-00
				REV A	
				SCALE: 1:3	SHEET 2 OF 3

LASERLINC, INC.
 PHONE: 888-707-4892
 INFO@LASERLINC.COM
 WWW.LASERLINC.COM

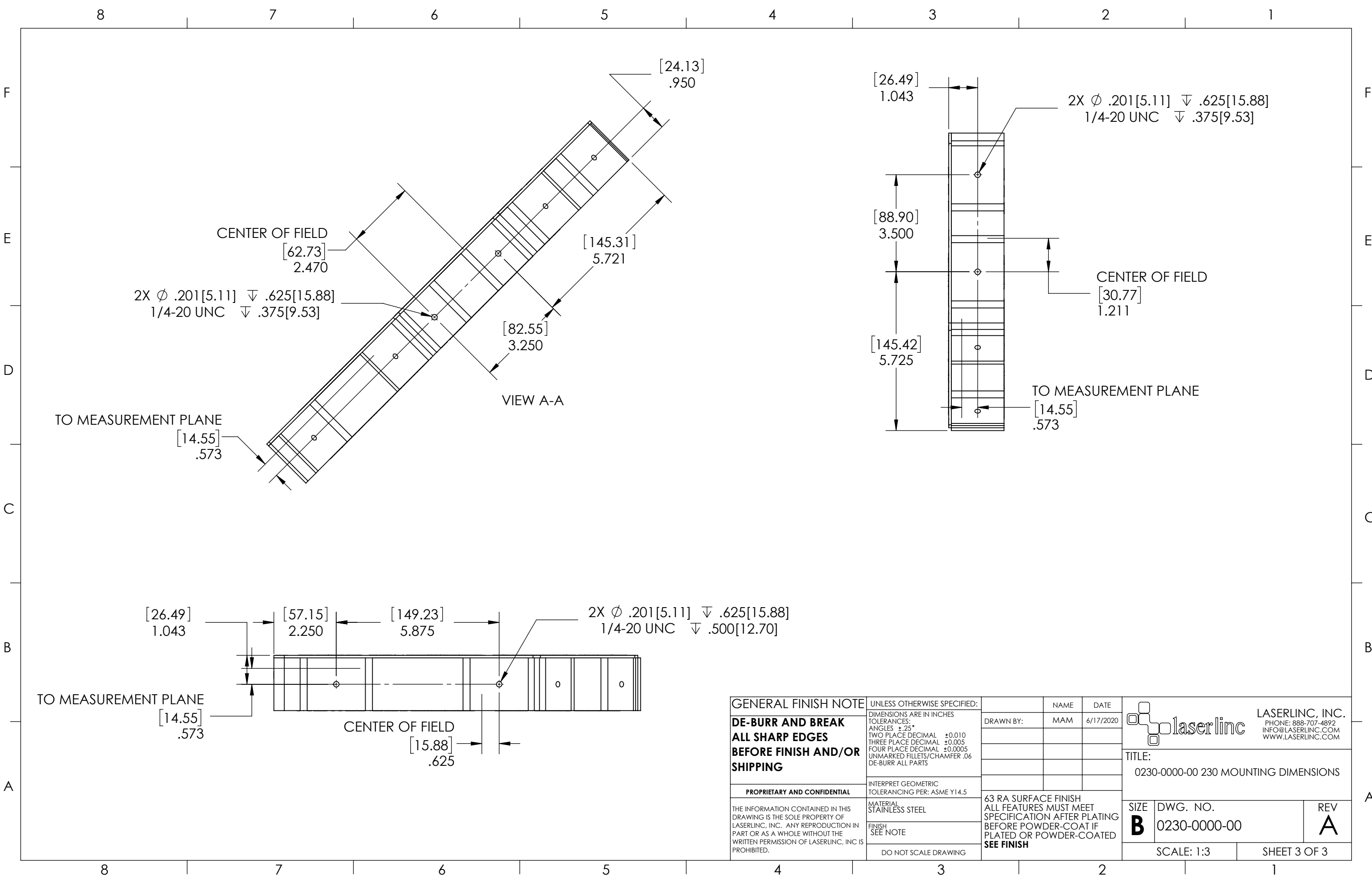

GENERAL FINISH NOTE
DE-BURR AND BREAK
ALL SHARP EDGES
BEFORE FINISH AND/OR SHIPPING

PROPRIETARY AND CONFIDENTIAL

THE INFORMATION CONTAINED IN THIS DRAWING IS THE SOLE PROPERTY OF LASERLINC, INC. ANY REPRODUCTION IN PART OR AS A WHOLE WITHOUT THE WRITTEN PERMISSION OF LASERLINC, INC. IS PROHIBITED.

UNLESS OTHERWISE SPECIFIED:
 DIMENSIONS ARE IN INCHES
 TOLERANCES:
 ANGLES \pm .25
 TWO PLACE DECIMAL \pm 0.010
 THREE PLACE DECIMAL \pm 0.005
 FOUR PLACE DECIMAL \pm 0.0005
 UNMARKED FILLETS/CHAMFER .06
 DE-BURR ALL PARTS

INTERPRET GEOMETRIC TOLERANCING PER: ASME Y14.5

MATERIAL: STAINLESS STEEL

FINISH: SEE NOTE

DO NOT SCALE DRAWING

NAME	DATE
MAM	6/17/2020

DRAWN BY:

63 RA SURFACE FINISH
 ALL FEATURES MUST MEET SPECIFICATION AFTER PLATING BEFORE POWDER-COAT IF PLATED OR POWDER-COATED
SEE FINISH

laserlinc LASERLINC, INC.
 PHONE: 888-707-4892
 INFO@LASERLINC.COM
 WWW.LASERLINC.COM

TITLE:
 0230-0000-00 230 MOUNTING DIMENSIONS

SIZE B	DWG. NO. 0230-0000-00	REV A
------------------	--------------------------	-----------------

SCALE: 1:3 SHEET 3 OF 3