

8

7

6

5

4

3

2

1

F

E

D

C

B

A

F

E

D

C

B

A

REVISIONS				
ZONE	REV.	DESCRIPTION	DATE	APPROVED
	A	Check-in	7/27/2011	ZRP

TLASER230 DUAL MOUNT ASSEMBLY OVERALL MOUNTING DIMENSIONS

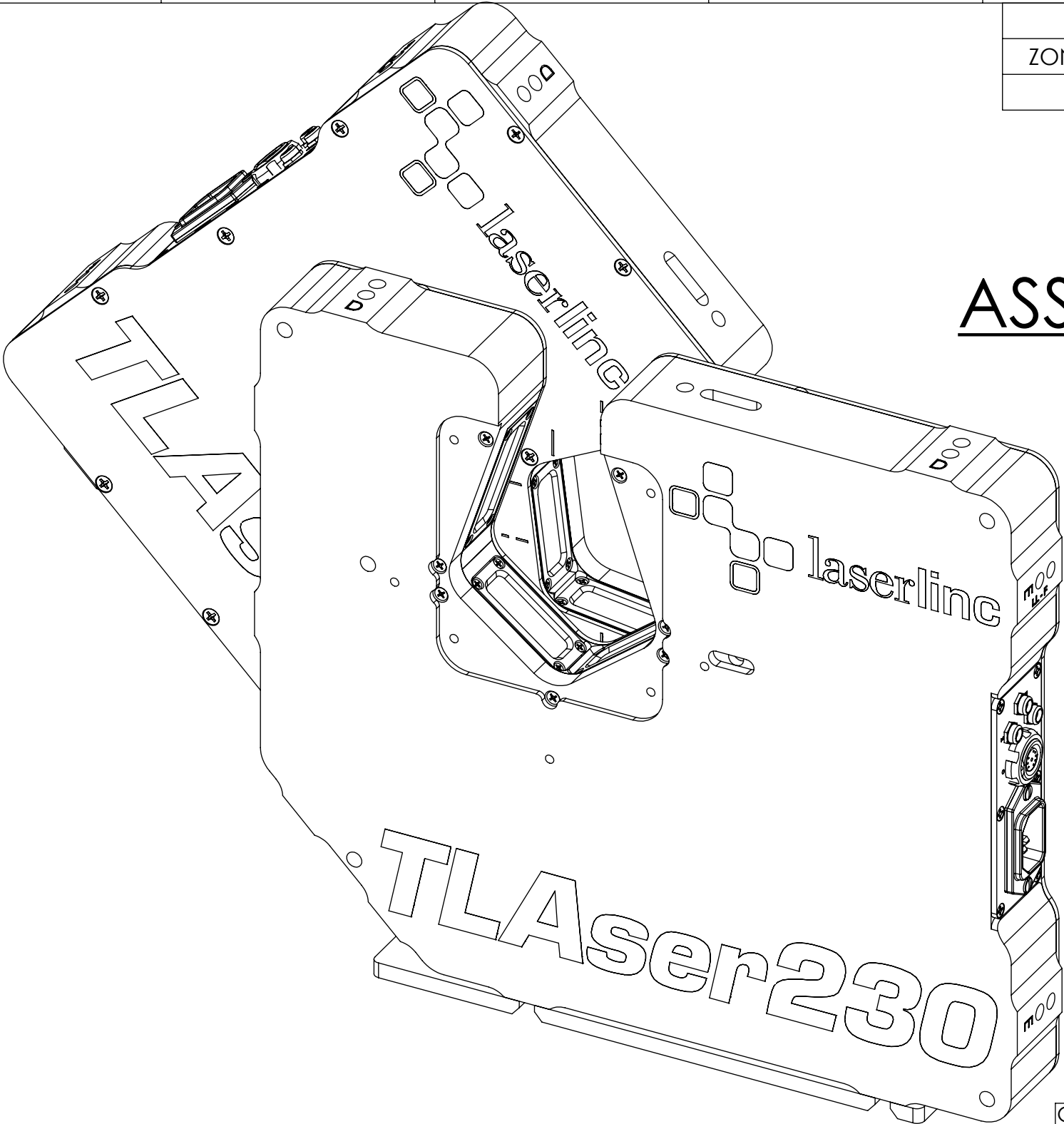

INDEX

- (1) COVER PAGE
- (2) DIMENSIONS

GENERAL FINISH NOTE DE-BURR AND BREAK ALL SHARP EDGES BEFORE FINISH AND/OR SHIPPING PROPRIETARY AND CONFIDENTIAL THE INFORMATION CONTAINED IN THIS DRAWING IS THE SOLE PROPERTY OF LASERLINC, INC. ANY REPRODUCTION IN PART OR AS A WHOLE WITHOUT THE WRITTEN PERMISSION OF LASERLINC, INC IS PROHIBITED.	UNLESS OTHERWISE SPECIFIED: DIMENSIONS ARE IN INCHES TOLERANCES: ANGLES ±.25° TWO PLACE DECIMAL ±0.010 THREE PLACE DECIMAL ±0.005 FOUR PLACE DECIMAL ±0.0005 UNMARKED FILLETS/CHAMFER .06 DE-BURR ALL PARTS	NAME ZRP	DATE 11/7/2019	 LaserLinc, Inc. Phone: 888-707-4892 Info@laserlinc.com www.laserlinc.com
	INTERPRET GEOMETRIC TOLERANCING PER: ASME Y14.5	DRAWN BY: ZRP	TITLE: 0231-0000-29 Fixture, Dual Mount TLAser230 Overall Mounting Dimensions	
MATERIAL FINISH DO NOT SCALE DRAWING	63 RA SURFACE FINISH ALL FEATURES MUST MEET SPECIFICATION AFTER PLATING BEFORE POWDER-COAT IF PLATED OR POWDER-COATED SEE FINISH	SIZE B	DWG. NO. 0231-0000-29	REV A
		SCALE: 1:2	SHEET 1 OF 2	

8

7

6

5

4

3

2

1

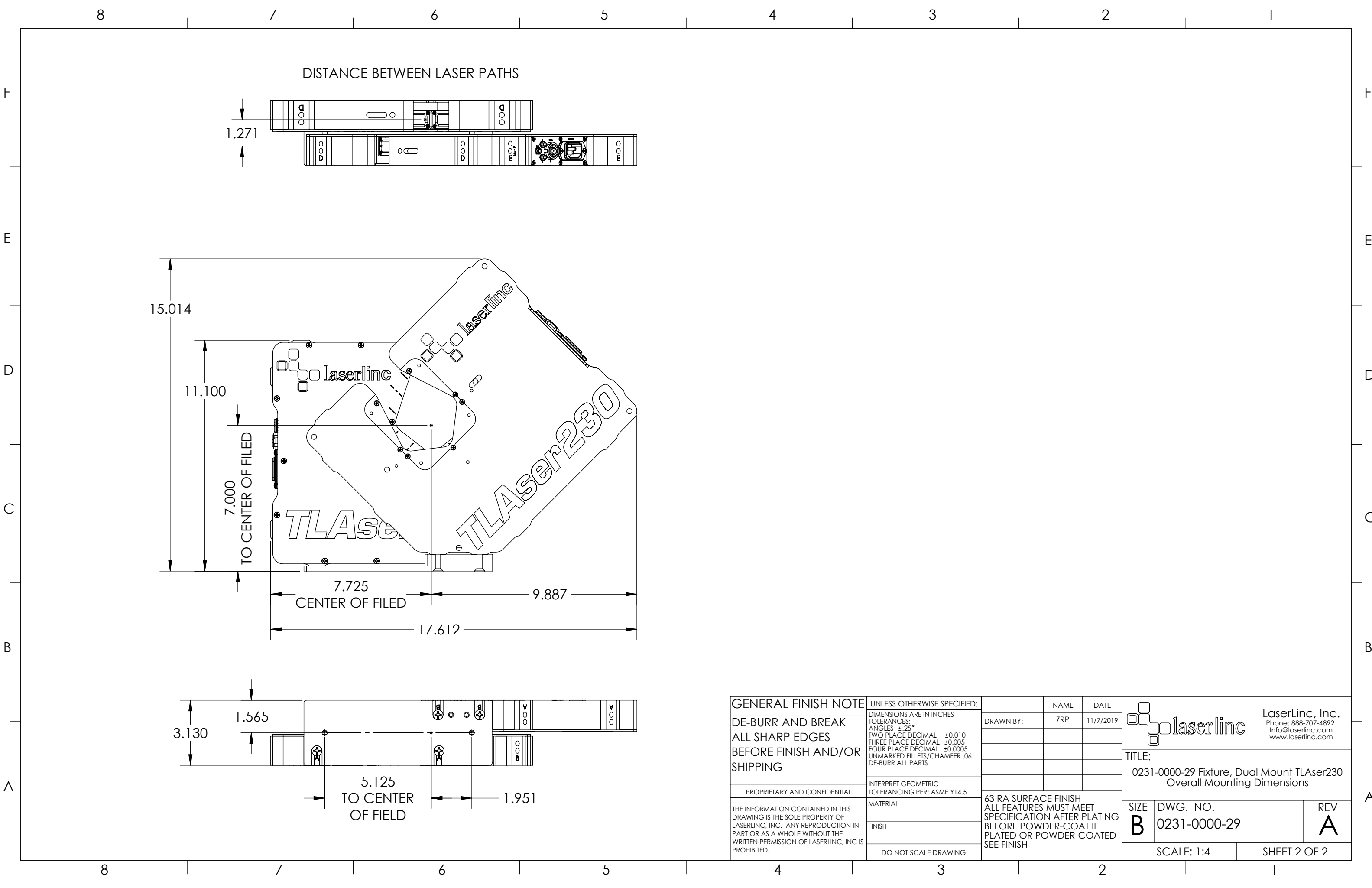

DISTANCE BETWEEN LASER PATHS

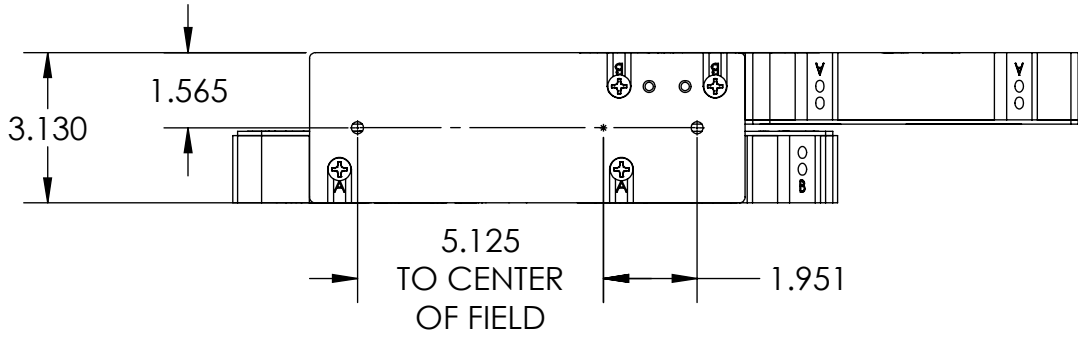
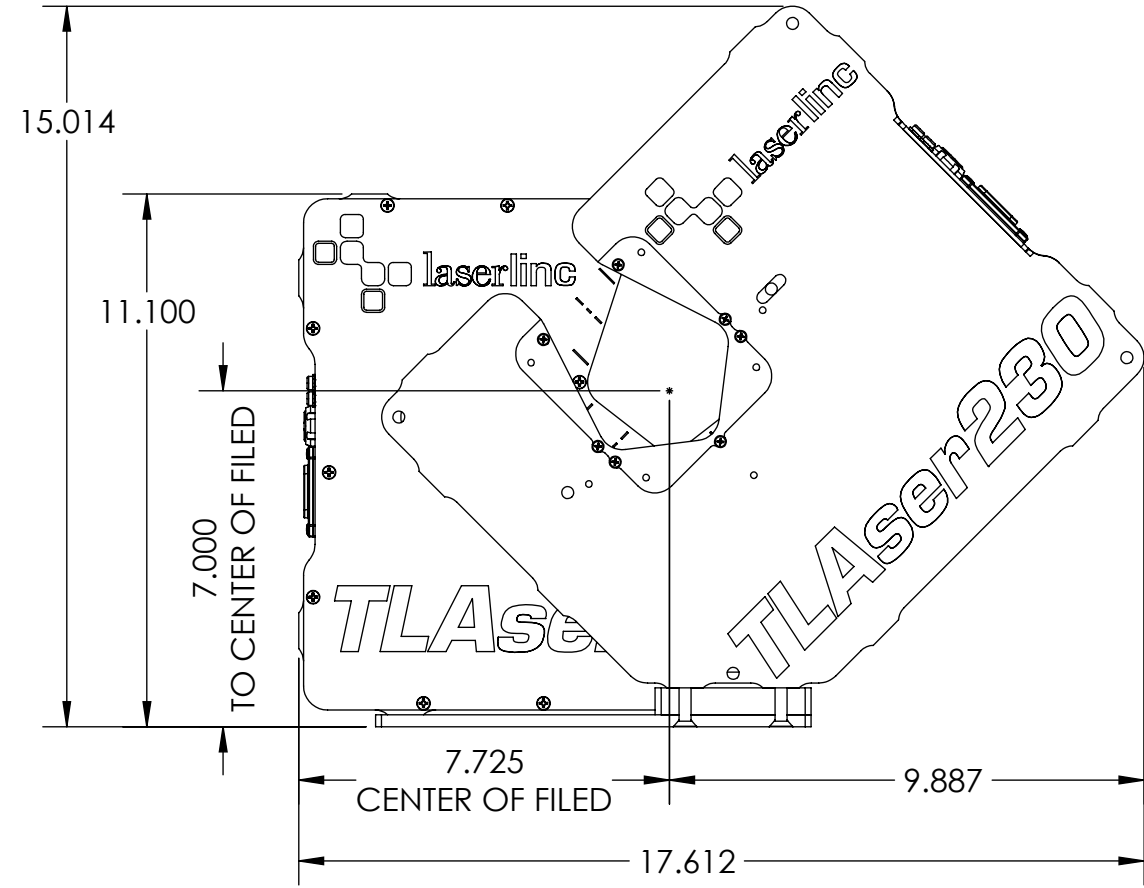
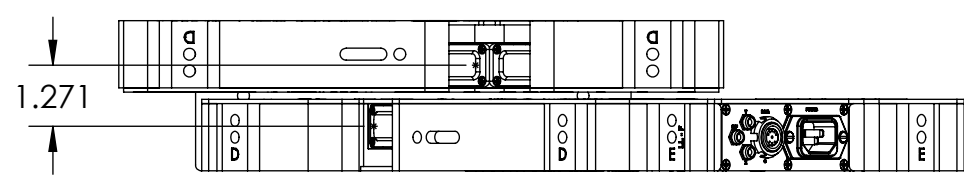

GENERAL FINISH NOTE DE-BURR AND BREAK ALL SHARP EDGES BEFORE FINISH AND/OR SHIPPING PROPRIETARY AND CONFIDENTIAL THE INFORMATION CONTAINED IN THIS DRAWING IS THE SOLE PROPERTY OF LASERLINC, INC. ANY REPRODUCTION IN PART OR AS A WHOLE WITHOUT THE WRITTEN PERMISSION OF LASERLINC, INC. IS PROHIBITED.	UNLESS OTHERWISE SPECIFIED: DIMENSIONS ARE IN INCHES TOLERANCES: ANGLES ±.25° TWO PLACE DECIMAL ±0.010 THREE PLACE DECIMAL ±0.005 FOUR PLACE DECIMAL ±0.0005 UNMARKED FILLETS/CHAMFER .06 DE-BURR ALL PARTS	NAME ZRP DATE 11/7/2019	 LaserLinc, Inc. Phone: 888-707-4892 Info@laserlinc.com www.laserlinc.com			
	INTERPRET GEOMETRIC TOLERANCING PER: ASME Y14.5	DRAWN BY:		TITLE: 0231-0000-29 Fixture, Dual Mount TLAser230 Overall Mounting Dimensions		
	MATERIAL	FINISH	63 RA SURFACE FINISH ALL FEATURES MUST MEET SPECIFICATION AFTER PLATING BEFORE POWDER-COAT IF PLATED OR POWDER-COATED SEE FINISH	SIZE B	DWG. NO. 0231-0000-29	REV A
	DO NOT SCALE DRAWING	SCALE: 1:4		SHEET 2 OF 2		