

8

7

6

5

4

3

2

1

ZONE		REV.	DESCRIPTION	DATE	APPROVED
		A	Check-In	9/27/2012	MAM

F

F

E

E

D

D

C

C

B

B

A

A

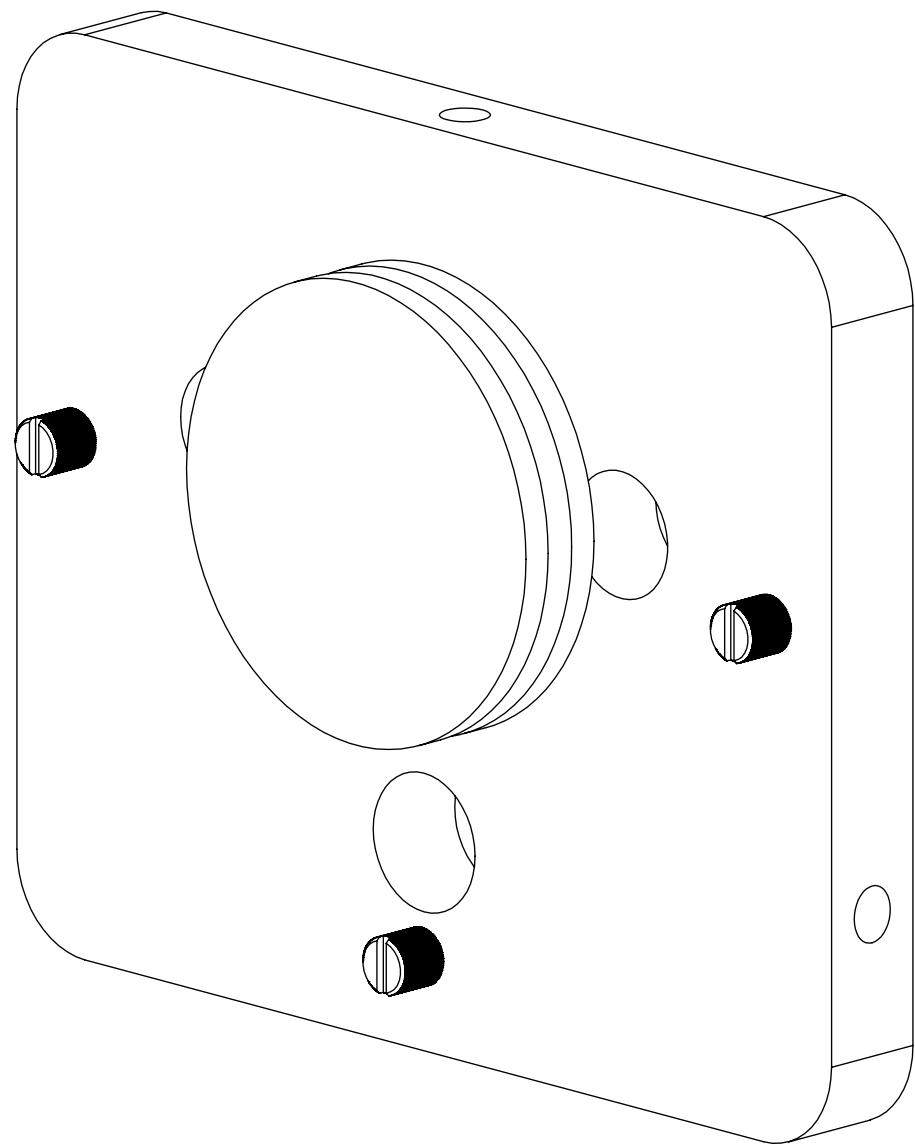

CALIBRATION FIXTURE FOR TLASER230 OVERALL DIMENSIONS

INDEX

- (1) COVER PAGE
- (2) FIXTURE DIMENSIONS
- (3) MOUNTED DIMENSIONS

GENERAL FINISH NOTE		UNLESS OTHERWISE SPECIFIED:		NAME	DATE	 LaserLinc, Inc. Phone: 888-707-4892 Info@laserlinc.com www.laserlinc.com
DE-BURR AND BREAK ALL SHARP EDGES BEFORE FINISH AND/OR SHIPPING		DIMENSIONS ARE IN INCHES TOLERANCES: ANGLES ±.25 TWO PLACE DECIMAL ±0.010 THREE PLACE DECIMAL ±0.005 FOUR PLACE DECIMAL ±0.0005 UNMARKED FILLETS/CHAMFER .06 DE-BURR ALL PARTS		DRAWN BY:	EMM	
PROPRIETARY AND CONFIDENTIAL THE INFORMATION CONTAINED IN THIS DRAWING IS THE SOLE PROPERTY OF LASERLINC, INC. ANY REPRODUCTION IN PART OR AS A WHOLE WITHOUT THE WRITTEN PERMISSION OF LASERLINC, INC. IS PROHIBITED.		INTERPRET GEOMETRIC TOLERANCING PER: ASME Y14.5 MATERIAL FINISH DO NOT SCALE DRAWING		63 RA SURFACE FINISH ALL FEATURES MUST MEET SPECIFICATION AFTER PLATING BEFORE POWDER-COAT IF PLATED OR POWDER-COATED SEE FINISH		TITLE: 0230-0000-34 Calibration Fixture for TLAser230 Overall Dimensions
		SIZE B	DWG. NO. 0230-0000-34	REV A		SCALE: 1:1 SHEET 1 OF 3

8

7

6

5

4

3

2

1

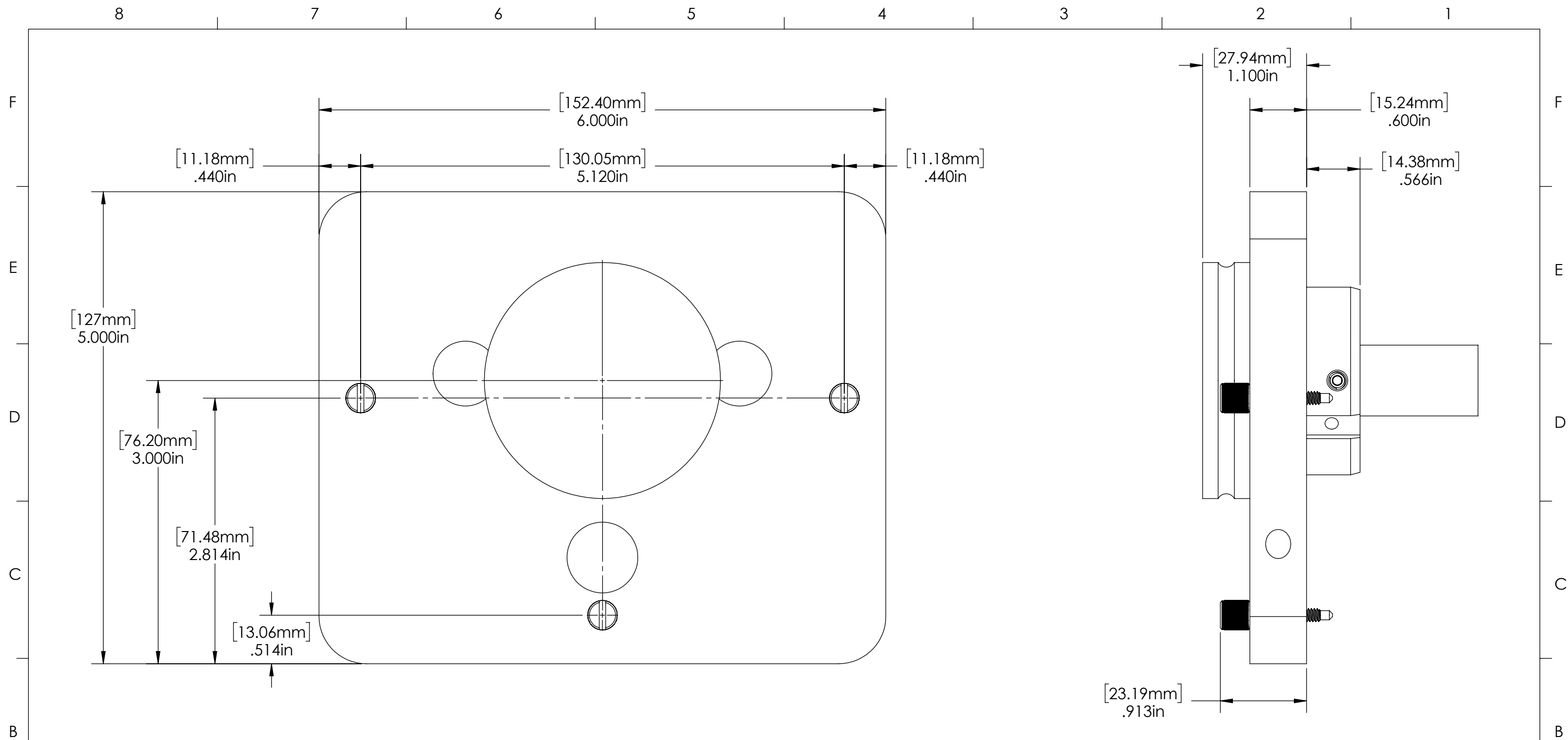

GENERAL FINISH NOTE		UNLESS OTHERWISE SPECIFIED:		NAME	DATE
DE-BURR AND BREAK ALL SHARP EDGES BEFORE FINISH AND/OR SHIPPING		DIMENSIONS ARE IN INCHES		DRAWN BY:	EMM
PROPRIETARY AND CONFIDENTIAL		TOLERANCES:			11/1/2019
THE INFORMATION CONTAINED IN THIS DRAWING IS THE SOLE PROPERTY OF LASERLINC, INC. ANY REPRODUCTION IN PART OR AS A WHOLE WITHOUT THE WRITTEN PERMISSION OF LASERLINC, INC. IS PROHIBITED.		ANGLES ±.25°			
		TWO PLACE DECIMAL ±0.010		 LaserLinc, Inc. Phone: 888-707-4892 info@laserlinc.com www.laserlinc.com	
		THREE PLACE DECIMAL ±0.005			
		FOUR PLACE DECIMAL ±0.0005			
		UNMARKED FILLETS/CHAMFER .06			
		DE-BURR ALL PARTS		TITLE:	
		INTERPRET GEOMETRIC TOLERANCING PER: ASME Y14.5		0230-0000-34 Calibration Fixture for TLAs230 Overall Dimensions	
		MATERIAL		SIZE	
		FINISH		DWG. NO.	
		DO NOT SCALE DRAWING		0230-0000-34	
				REV	
				A	
				SCALE: 1:1	
				SHEET 2 OF 3	

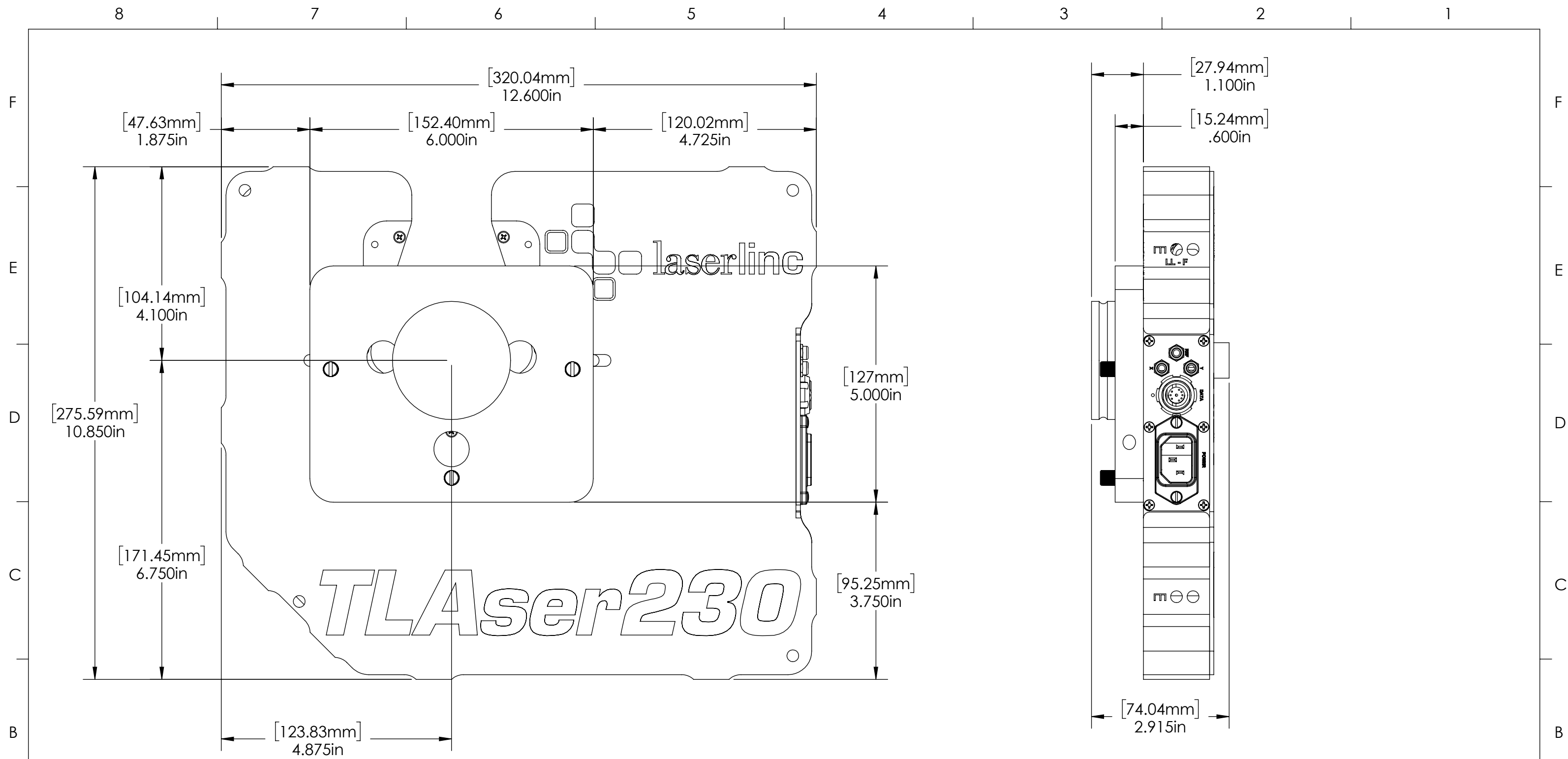

GENERAL FINISH NOTE		UNLESS OTHERWISE SPECIFIED:		NAME	DATE
DE-BURR AND BREAK ALL SHARP EDGES BEFORE FINISH AND/OR SHIPPING		DIMENSIONS ARE IN INCHES TOLERANCES: ANGLES ±.25 TWO PLACE DECIMAL ±0.010 THREE PLACE DECIMAL ±0.005 FOUR PLACE DECIMAL ±0.0005 UNMARKED FILLETS/CHAMFER .06 DE-BURR ALL PARTS		DRAWN BY:	EMM 11/1/2019
PROPRIETARY AND CONFIDENTIAL		INTERPRET GEOMETRIC TOLERANCING PER: ASME Y14.5			
THE INFORMATION CONTAINED IN THIS DRAWING IS THE SOLE PROPERTY OF LASERLINC, INC. ANY REPRODUCTION IN PART OR AS A WHOLE WITHOUT THE WRITTEN PERMISSION OF LASERLINC, INC. IS PROHIBITED.		MATERIAL		63 RA SURFACE FINISH ALL FEATURES MUST MEET SPECIFICATION AFTER PLATING BEFORE POWDER-COAT IF PLATED OR POWDER-COATED SEE FINISH	
		FINISH			
		DO NOT SCALE DRAWING			
 LaserLinc, Inc. Phone: 888-707-4892 Info@laserlinc.com www.laserlinc.com				TITLE:	
				0230-0000-34 Calibration Fixture for TLAser230 Overall Dimensions	
SIZE	DWG. NO.			REV	
B	0230-0000-34			A	
SCALE: 1:2			SHEET 3 OF 3		