

8

7

6

5

4

3

2

1

ZONE		REV.	DESCRIPTION	DATE	APPROVED
		A	Check-In	9/9/2013	MAM

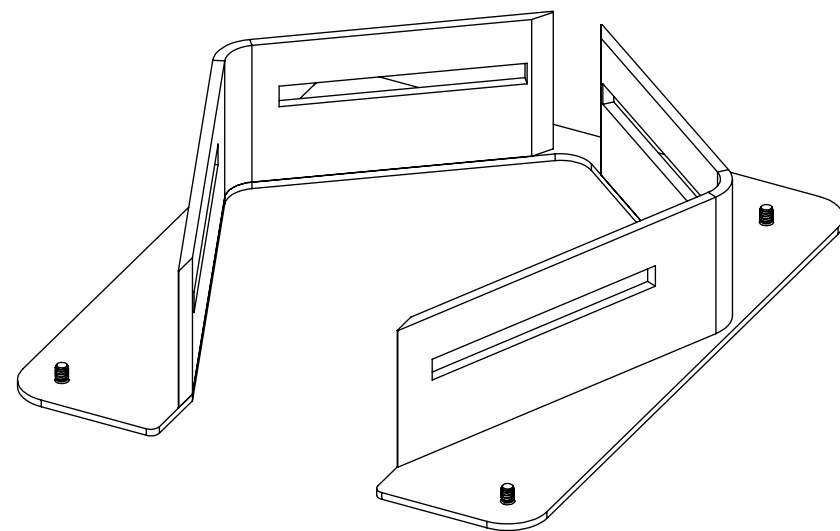

WINDOW GUARD FOR TLASER260 MICROMETER OVERALL DIMENSIONS

INDEX

- (1) COVER PAGE
- (2) DIMENSIONS

GENERAL FINISH NOTE		UNLESS OTHERWISE SPECIFIED:		NAME	DATE	 LaserLinc, Inc. Phone: 888-707-4892 info@laserlinc.com www.laserlinc.com
DE-BURR AND BREAK ALL SHARP EDGES BEFORE FINISH AND/OR SHIPPING		DIMENSIONS ARE IN INCHES TOLERANCES: ANGLES ±.25° TWO PLACE DECIMAL ±0.010 THREE PLACE DECIMAL ±0.005 FOUR PLACE DECIMAL ±0.0005 UNMARKED FILLETS/CHAMFER .06 DE-BURR ALL PARTS		DRAWN BY:	MAM	
PROPRIETARY AND CONFIDENTIAL THE INFORMATION CONTAINED IN THIS DRAWING IS THE SOLE PROPERTY OF LASERLINC, INC. ANY REPRODUCTION IN PART OR AS A WHOLE WITHOUT THE WRITTEN PERMISSION OF LASERLINC, INC. IS PROHIBITED.		INTERPRET GEOMETRIC TOLERANCING PER: ASME Y14.5 MATERIAL FINISH DO NOT SCALE DRAWING		63 RA SURFACE FINISH ALL FEATURES MUST MEET SPECIFICATION AFTER PLATING BEFORE POWDER-COAT IF PLATED OR POWDER-COATED SEE FINISH		TITLE: 0260-0000-31 WINDOW GUARD FOR TLASER260 MICROMETER OVERALL DIMENSIONS
				SIZE	DWG. NO.	REV
				B	0260-0000-31	A
				SCALE: 1:4		SHEET 1 OF 2

8

7

6

5

4

3

2

1

F

E

D

C

B

A

F

E

D

C

B

A

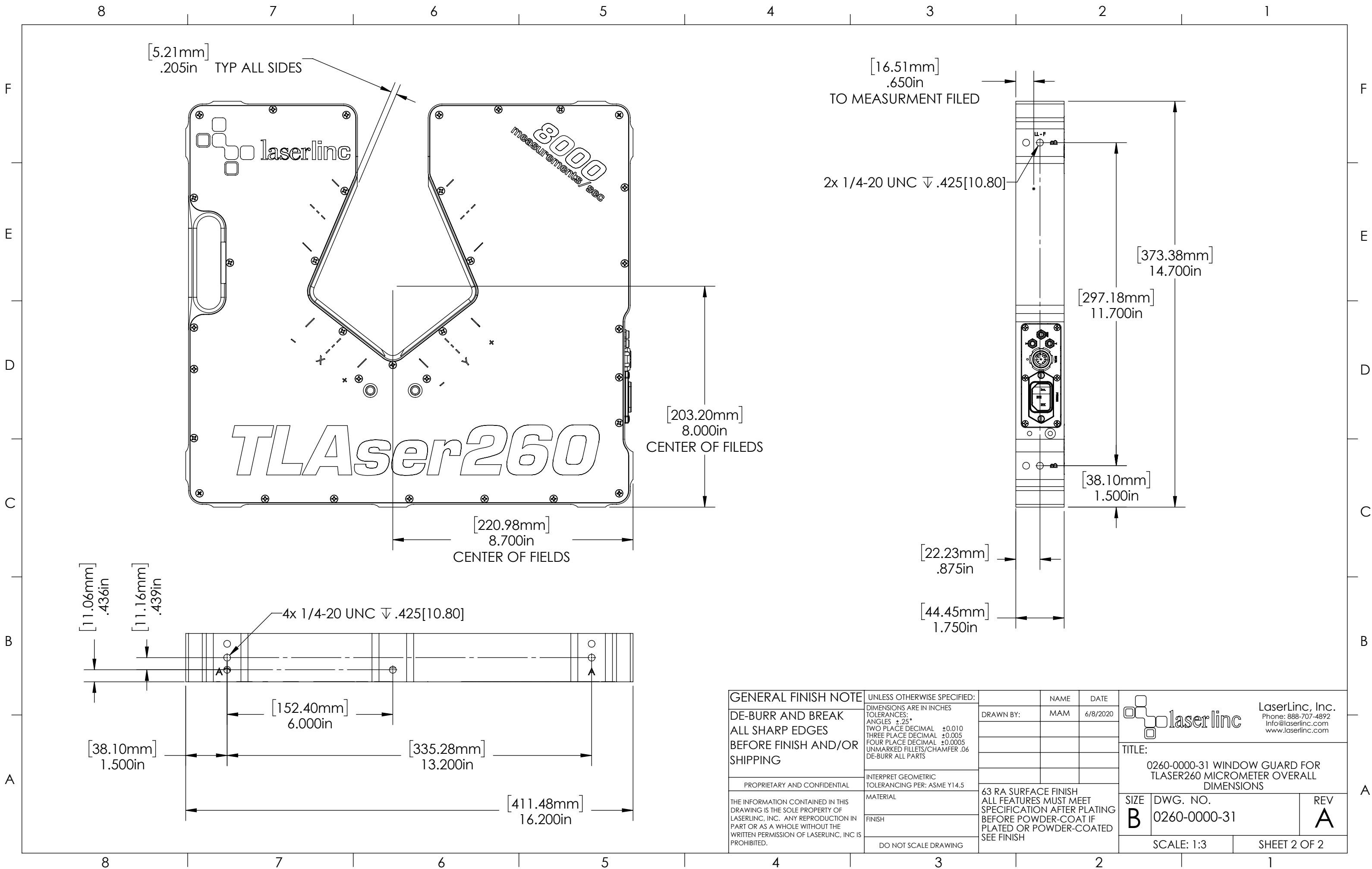

GENERAL FINISH NOTE	UNLESS OTHERWISE SPECIFIED:	NAME	DATE	 LaserLinc, Inc. Phone: 888-707-4892 Info@laserline.com www.laserline.com
	DIMENSIONS ARE IN INCHES TOLERANCES: ANGLES \pm .25° TWO PLACE DECIMAL \pm 0.010 THREE PLACE DECIMAL \pm 0.005 FOUR PLACE DECIMAL \pm 0.0005 UNMARKED FILLETS/CHAMFER .06 DE-BURR ALL PARTS	DRAWN BY:	MAM	
DE-BURR AND BREAK ALL SHARP EDGES BEFORE FINISH AND/OR SHIPPING	INTERPRET GEOMETRIC TOLERANCING PER: ASME Y14.5	TITLE: 0260-0000-31 WINDOW GUARD FOR TLASER260 MICROMETER OVERALL DIMENSIONS		SIZE B DWG. NO. 0260-0000-31 REV A
PROPRIETARY AND CONFIDENTIAL THE INFORMATION CONTAINED IN THIS DRAWING IS THE SOLE PROPERTY OF LASERLINC, INC. ANY REPRODUCTION IN PART OR AS A WHOLE WITHOUT THE WRITTEN PERMISSION OF LASERLINC, INC IS PROHIBITED.	MATERIAL FINISH DO NOT SCALE DRAWING	63 RA SURFACE FINISH ALL FEATURES MUST MEET SPECIFICATION AFTER PLATING BEFORE POWDER-COAT IF PLATED OR POWDER-COATED SEE FINISH		