

8

7

6

5

4

3

2

1

ZONE		REV.	DESCRIPTION	DATE	APPROVED
		A	Check-In	10/23/2012	MAM

F

F

E

E

D

D

C

C

B

B

A

A

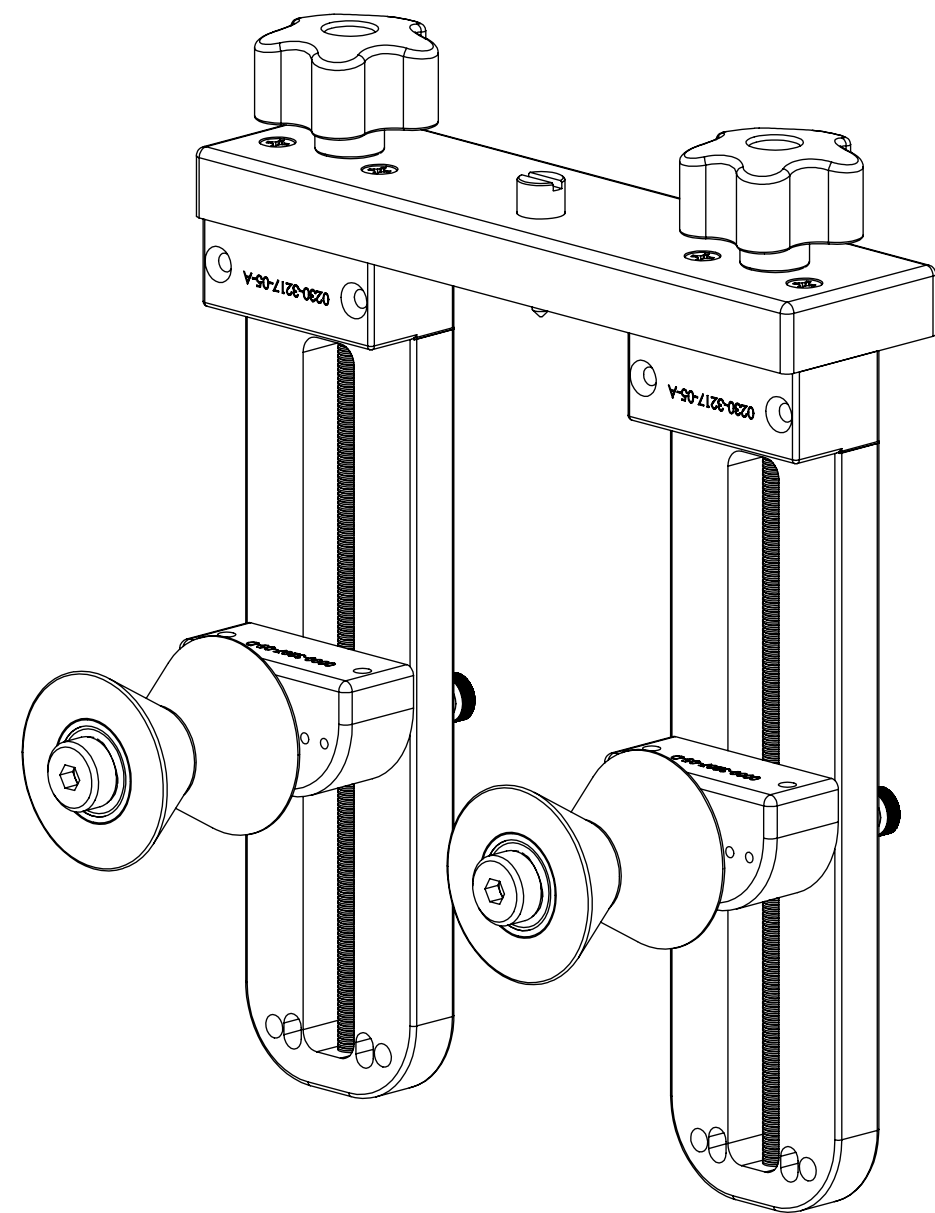

# TLASER260 BODY MOUNT ROLLER GUIDE OVERALLS

## INDEX

- (1) COVER PAGE
- (2) FIXTURE DIMENSIONS
- (3) MOUNTED DIMENSIONS

GENERAL FINISH NOTE DE-BURR AND BREAK ALL SHARP EDGES BEFORE FINISH AND/OR SHIPPING	UNLESS OTHERWISE SPECIFIED: DIMENSIONS ARE IN INCHES TOLERANCES: ANGLES ±.25 TWO PLACE DECIMAL ±0.010 THREE PLACE DECIMAL ±0.005 FOUR PLACE DECIMAL ±0.0005 UNMARKED FILLETS/CHAMFER .06 DE-BURR ALL PARTS	NAME	DATE	 <b>LASERLINC, INC.</b> PHONE: 888-707-4892 INFO@LASERLINC.COM WWW.LASERLINC.COM
	INTERPRET GEOMETRIC TOLERANCING PER: ASME Y14.5	DRAWN BY:	EMM	
PROPRIETARY AND CONFIDENTIAL	MATERIAL	63 RA SURFACE FINISH ALL FEATURES MUST MEET SPECIFICATION AFTER PLATING BEFORE POWDER-COAT IF PLATED OR POWDER-COATED SEE FINISH		TITLE: 0260-0000-61 TLASER260 BODY MOUNT ROLLER GUIDE OVERALLS
THE INFORMATION CONTAINED IN THIS DRAWING IS THE SOLE PROPERTY OF LASERLINC, INC. ANY REPRODUCTION IN PART OR AS A WHOLE WITHOUT THE WRITTEN PERMISSION OF LASERLINC, INC. IS PROHIBITED.	FINISH	SIZE	DWG. NO.	REV
DO NOT SCALE DRAWING		B	0260-0000-61	A
		SCALE: 1:2		SHEET 1 OF 3

8

7

6

5

4

3

2

1

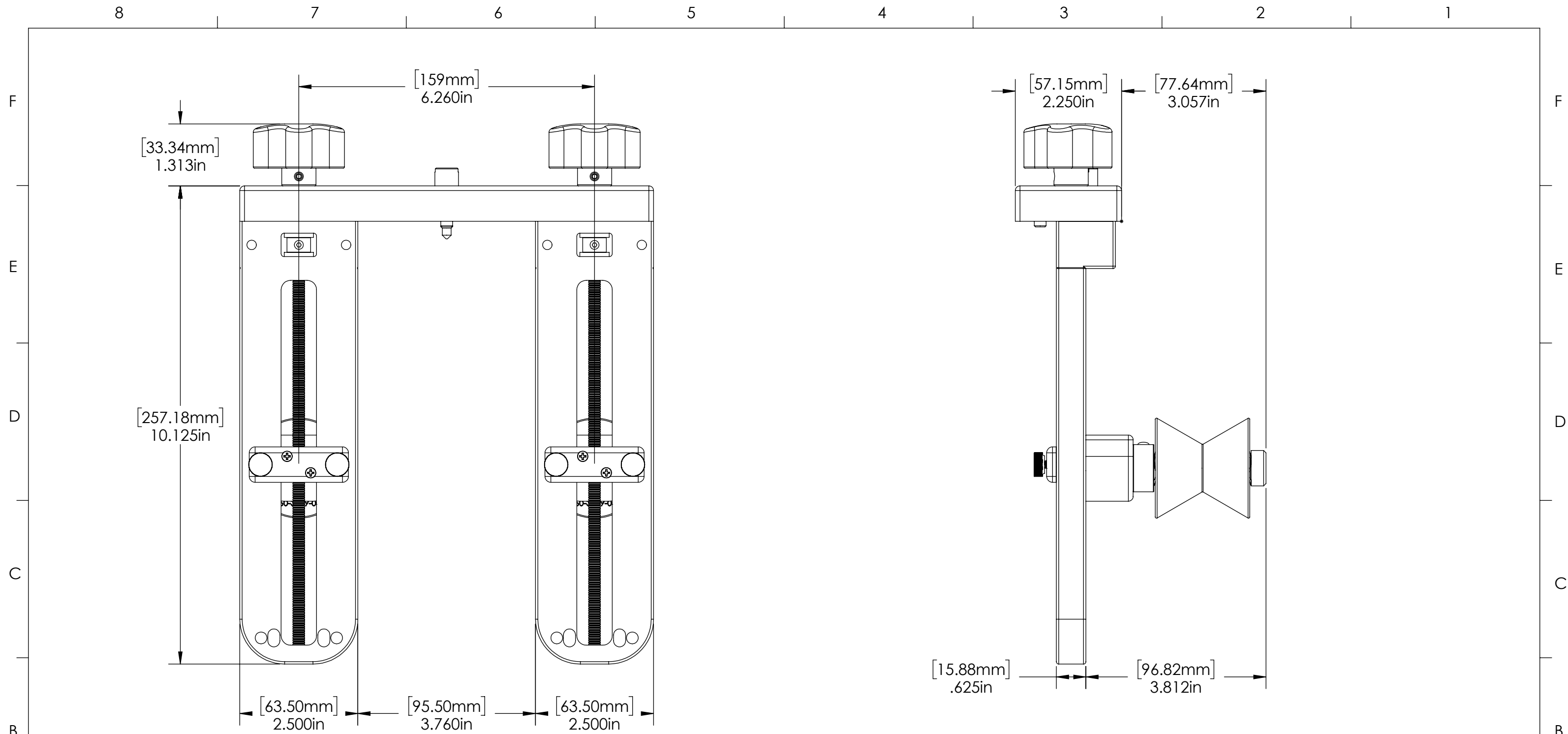

<b>GENERAL FINISH NOTE</b> DE-BURR AND BREAK ALL SHARP EDGES BEFORE FINISH AND/OR SHIPPING	UNLESS OTHERWISE SPECIFIED: DIMENSIONS ARE IN INCHES TOLERANCES: ANGLES ±.25° TWO PLACE DECIMAL ±0.010 THREE PLACE DECIMAL ±0.005 FOUR PLACE DECIMAL ±0.0005 UNMARKED FILLETS/CHAMFER .06 DE-BURR ALL PARTS	NAME DATE	 <b>LASERLINC, INC.</b> PHONE: 888-707-4892 INFO@LASERLINC.COM WWW.LASERLINC.COM			
	INTERPRET GEOMETRIC TOLERANCING PER: ASME Y14.5	DRAWN BY: EMM DATE: 12/18/2020		<b>TITLE:</b> 0260-0000-61 TLASER260 BODY MOUNT ROLLER GUIDE OVERALLS		
PROPRIETARY AND CONFIDENTIAL  THE INFORMATION CONTAINED IN THIS DRAWING IS THE SOLE PROPERTY OF LASERLINC, INC. ANY REPRODUCTION IN PART OR AS A WHOLE WITHOUT THE WRITTEN PERMISSION OF LASERLINC, INC. IS PROHIBITED.	MATERIAL  FINISH  DO NOT SCALE DRAWING	63 RA SURFACE FINISH ALL FEATURES MUST MEET SPECIFICATION AFTER PLATING BEFORE POWDER-COAT IF PLATED OR POWDER-COATED SEE FINISH	<table border="1"> <tr> <td><b>SIZE</b> B</td> <td><b>DWG. NO.</b> 0260-0000-61</td> <td><b>REV</b> A</td> </tr> </table>	<b>SIZE</b> B	<b>DWG. NO.</b> 0260-0000-61	<b>REV</b> A
<b>SIZE</b> B	<b>DWG. NO.</b> 0260-0000-61	<b>REV</b> A				
		SCALE: 1:2	SHEET 2 OF 3			

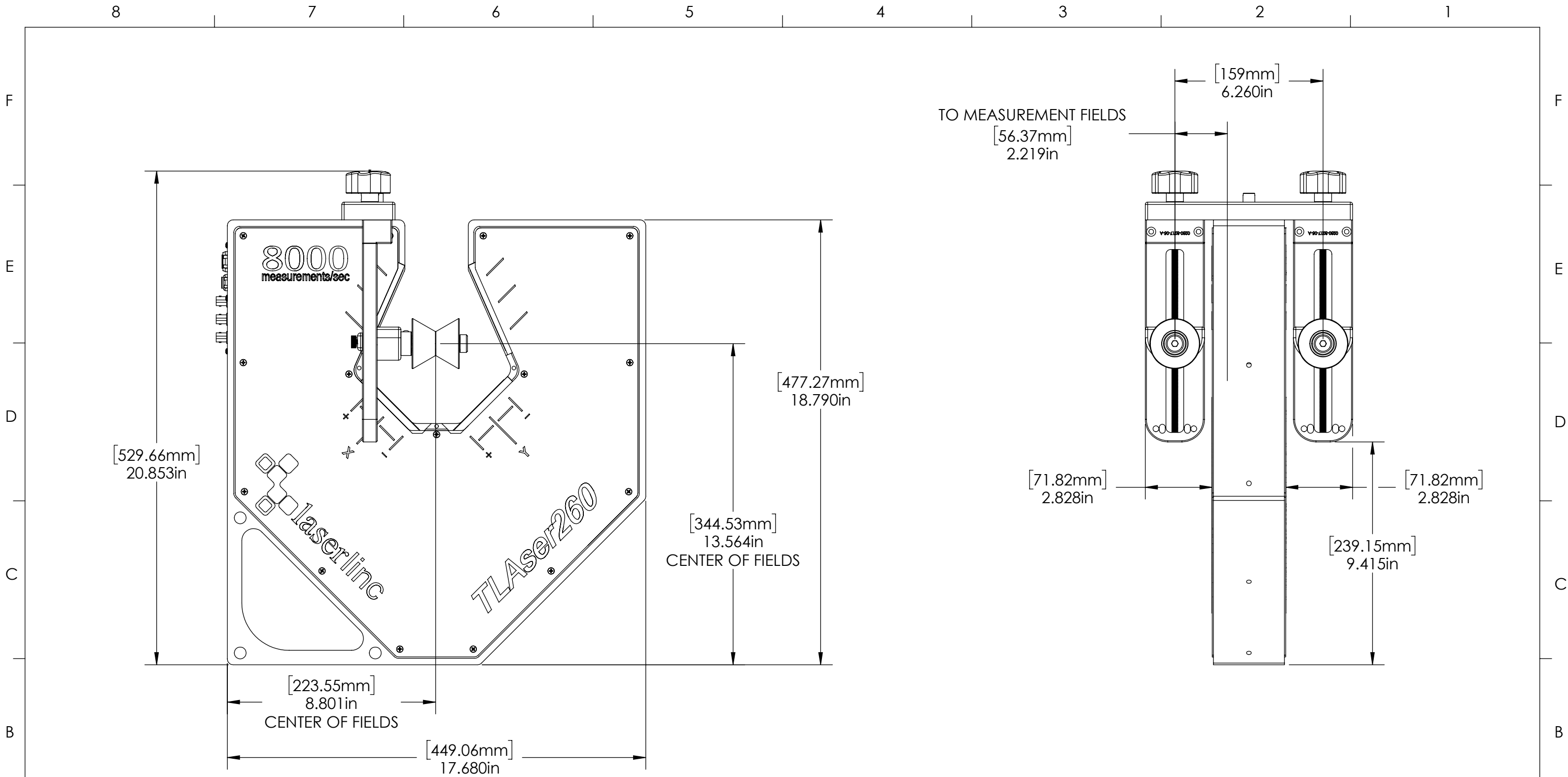

<b>GENERAL FINISH NOTE</b>		UNLESS OTHERWISE SPECIFIED:		NAME	DATE		
DE-BURR AND BREAK ALL SHARP EDGES BEFORE FINISH AND/OR SHIPPING		DIMENSIONS ARE IN INCHES TOLERANCES: ANGLES ±.25 TWO PLACE DECIMAL ±0.010 THREE PLACE DECIMAL ±0.005 FOUR PLACE DECIMAL ±0.0005 UNMARKED FILLETS/CHAMFER .06 DE-BURR ALL PARTS		DRAWN BY:	EMM 12/18/2020		
PROPRIETARY AND CONFIDENTIAL		INTERPRET GEOMETRIC TOLERANCING PER: ASME Y14.5		 <b>LASERLINC, INC.</b> PHONE: 888-707-4892 INFO@LASERLINC.COM WWW.LASERLINC.COM			
THE INFORMATION CONTAINED IN THIS DRAWING IS THE SOLE PROPERTY OF LASERLINC, INC. ANY REPRODUCTION IN PART OR AS A WHOLE WITHOUT THE WRITTEN PERMISSION OF LASERLINC, INC. IS PROHIBITED.		MATERIAL				TITLE: 0260-0000-61 TLASER260 BODY MOUNT ROLLER GUIDE OVERALLS	
		FINISH				63 RA SURFACE FINISH ALL FEATURES MUST MEET SPECIFICATION AFTER PLATING BEFORE POWDER-COAT IF PLATED OR POWDER-COATED SEE FINISH	
		DO NOT SCALE DRAWING		SIZE	DWG. NO.		
				<b>B</b>	0260-0000-61		
				REV	<b>A</b>		
				SCALE: 1:4	SHEET 3 OF 3		