

8

7

6

5

4

3

2

1

| ZONE | | REV. | DESCRIPTION | DATE | APPROVED |
|------|--|------|-------------|------------|----------|
| | | A | Check-in | 10/19/2011 | ZRP |

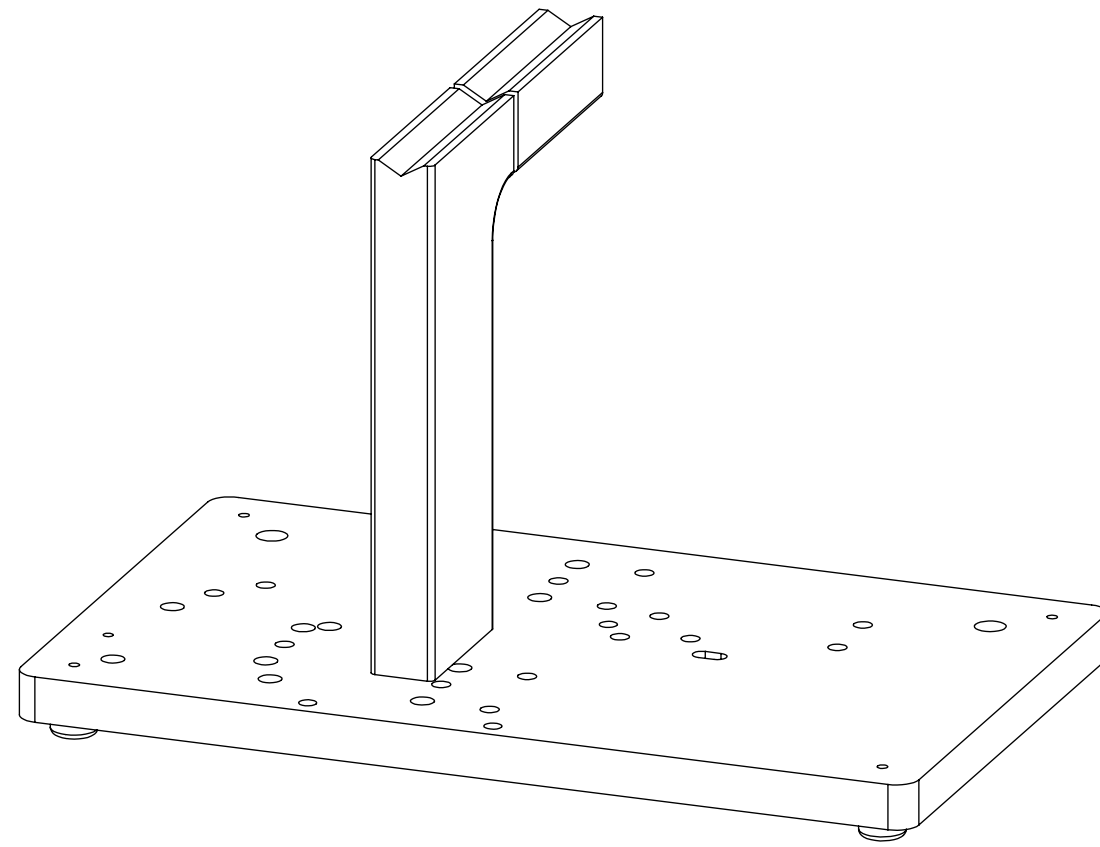

TRITON312 V-BLOCK FIXTURE, STAINLESS STEEL OVERALLS

F

F

E

E

D

D

C

C

B

B

A

A

INDEX

- (1) COVER PAGE
- (2) DIMENSIONS

| | | | | | | |
|--|--|--|--|--|------|--|
| GENERAL FINISH NOTE | | UNLESS OTHERWISE SPECIFIED: | | NAME | DATE |  LASERLINC, INC. PHONE: 888-707-4892 INFO@LASERLINC.COM WWW.LASERLINC.COM |
| DE-BURR AND BREAK ALL SHARP EDGES BEFORE FINISH AND/OR SHIPPING | | DIMENSIONS ARE IN INCHES TOLERANCES: ANGLES ±.25° TWO PLACE DECIMAL ±0.010 THREE PLACE DECIMAL ±0.005 FOUR PLACE DECIMAL ±0.0005 UNMARKED FILLETS/CHAMFER .06 DE-BURR ALL PARTS | | DRAWN BY: | EMM | |
| PROPRIETARY AND CONFIDENTIAL | | INTERPRET GEOMETRIC TOLERANCING PER: ASME Y14.5 | | | | TITLE: 0312-0000-21 TRITON312 V-BLOCK FIXTURE, STAINLESS STEEL OVERALLS |
| THE INFORMATION CONTAINED IN THIS DRAWING IS THE SOLE PROPERTY OF LASERLINC, INC. ANY REPRODUCTION IN PART OR AS A WHOLE WITHOUT THE WRITTEN PERMISSION OF LASERLINC, INC. IS PROHIBITED. | | MATERIAL | | 63 RA SURFACE FINISH ALL FEATURES MUST MEET SPECIFICATION AFTER PLATING BEFORE POWDER-COAT IF PLATED OR POWDER-COATED SEE FINISH | | SIZE B |
| | | FINISH | | | | DWG. NO. 0312-0000-21 |
| | | DO NOT SCALE DRAWING | | | | REV A |
| | | | | SCALE: 1:2 | | SHEET 1 OF 3 |

8

7

6

5

4

3

2

1

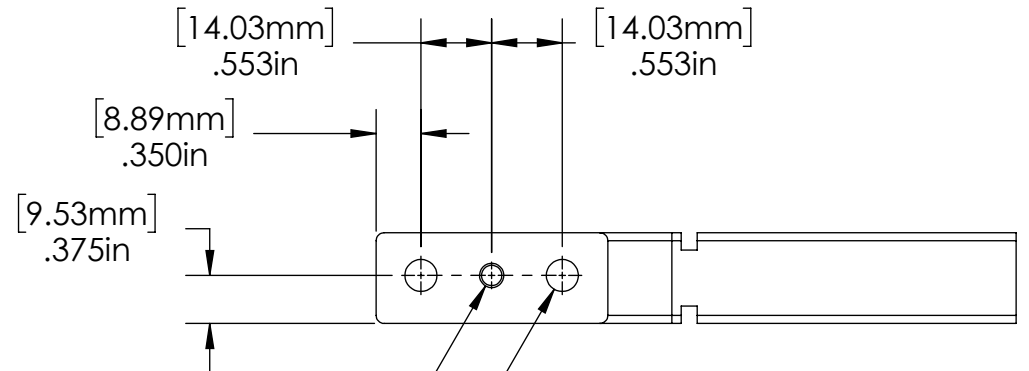
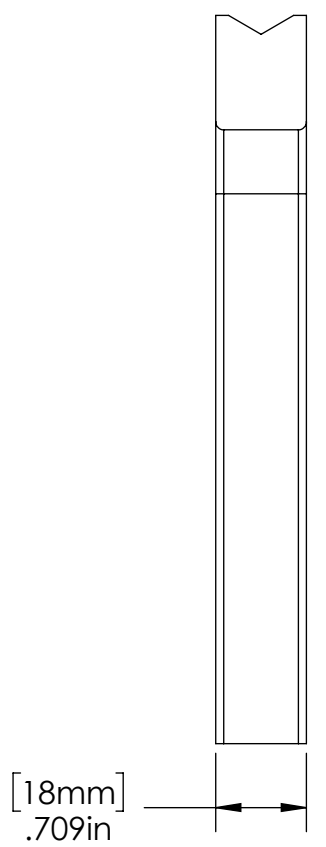
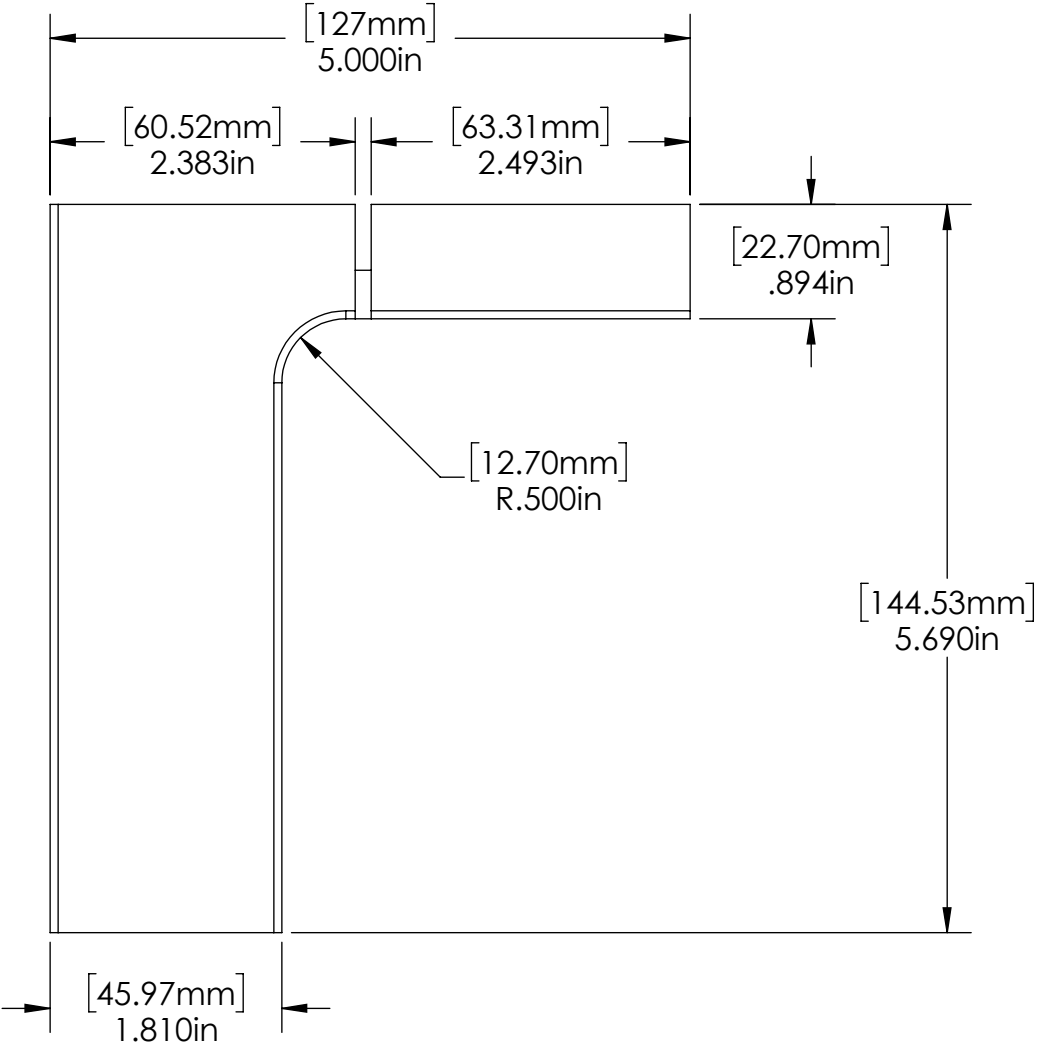
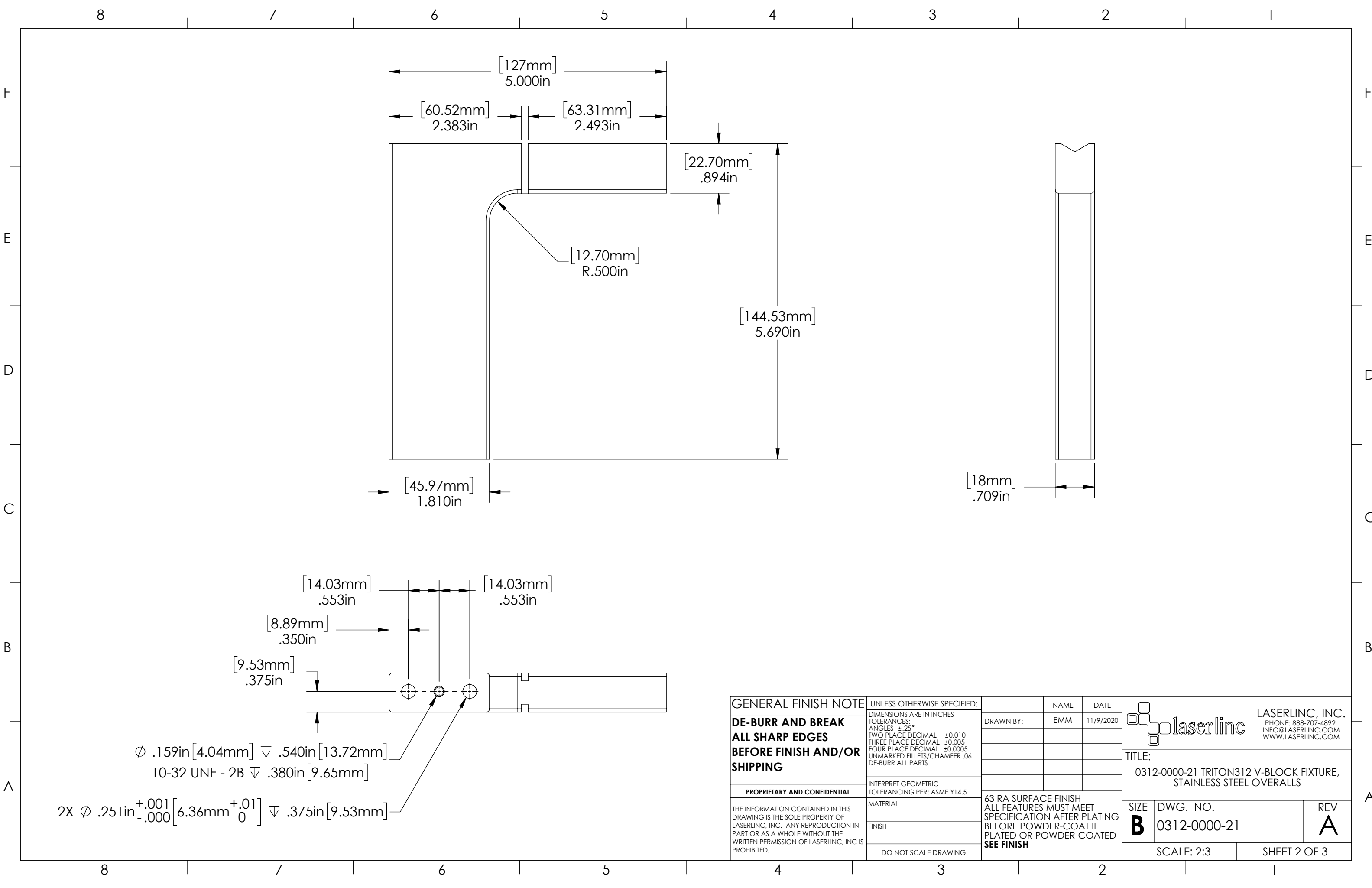

$\varnothing .159\text{in} [4.04\text{mm}] \nabla .540\text{in} [13.72\text{mm}]$
 10-32 UNF - 2B $\nabla .380\text{in} [9.65\text{mm}]$

2X $\varnothing .251\text{in} \begin{matrix} +.001 \\ -.000 \end{matrix} [6.36\text{mm} \begin{matrix} +.01 \\ 0 \end{matrix}] \nabla .375\text{in} [9.53\text{mm}]$

| | | | | | |
|--|---|---|--|--|------------------------------|
| GENERAL FINISH NOTE DE-BURR AND BREAK ALL SHARP EDGES BEFORE FINISH AND/OR SHIPPING | UNLESS OTHERWISE SPECIFIED: DIMENSIONS ARE IN INCHES TOLERANCES: ANGLES ±.25° TWO PLACE DECIMAL ±0.010 THREE PLACE DECIMAL ±0.005 FOUR PLACE DECIMAL ±0.0005 UNMARKED FILLETS/CHAMFER .06 DE-BURR ALL PARTS | NAME DATE |  LASERLINC, INC. PHONE: 888-707-4892 INFO@LASERLINC.COM WWW.LASERLINC.COM | | |
| | PROPRIETARY AND CONFIDENTIAL THE INFORMATION CONTAINED IN THIS DRAWING IS THE SOLE PROPERTY OF LASERLINC, INC. ANY REPRODUCTION IN PART OR AS A WHOLE WITHOUT THE WRITTEN PERMISSION OF LASERLINC, INC. IS PROHIBITED. | INTERPRET GEOMETRIC TOLERANCING PER: ASME Y14.5 MATERIAL FINISH DO NOT SCALE DRAWING | DRAWN BY: EMM 11/9/2020 | TITLE: 0312-0000-21 TRITON312 V-BLOCK FIXTURE, STAINLESS STEEL OVERALLS | |
| | | 63 RA SURFACE FINISH ALL FEATURES MUST MEET SPECIFICATION AFTER PLATING BEFORE POWDER-COAT IF PLATED OR POWDER-COATED SEE FINISH | | SIZE B DWG. NO. 0312-0000-21 SCALE: 2:3 | REV A SHEET 2 OF 3 |

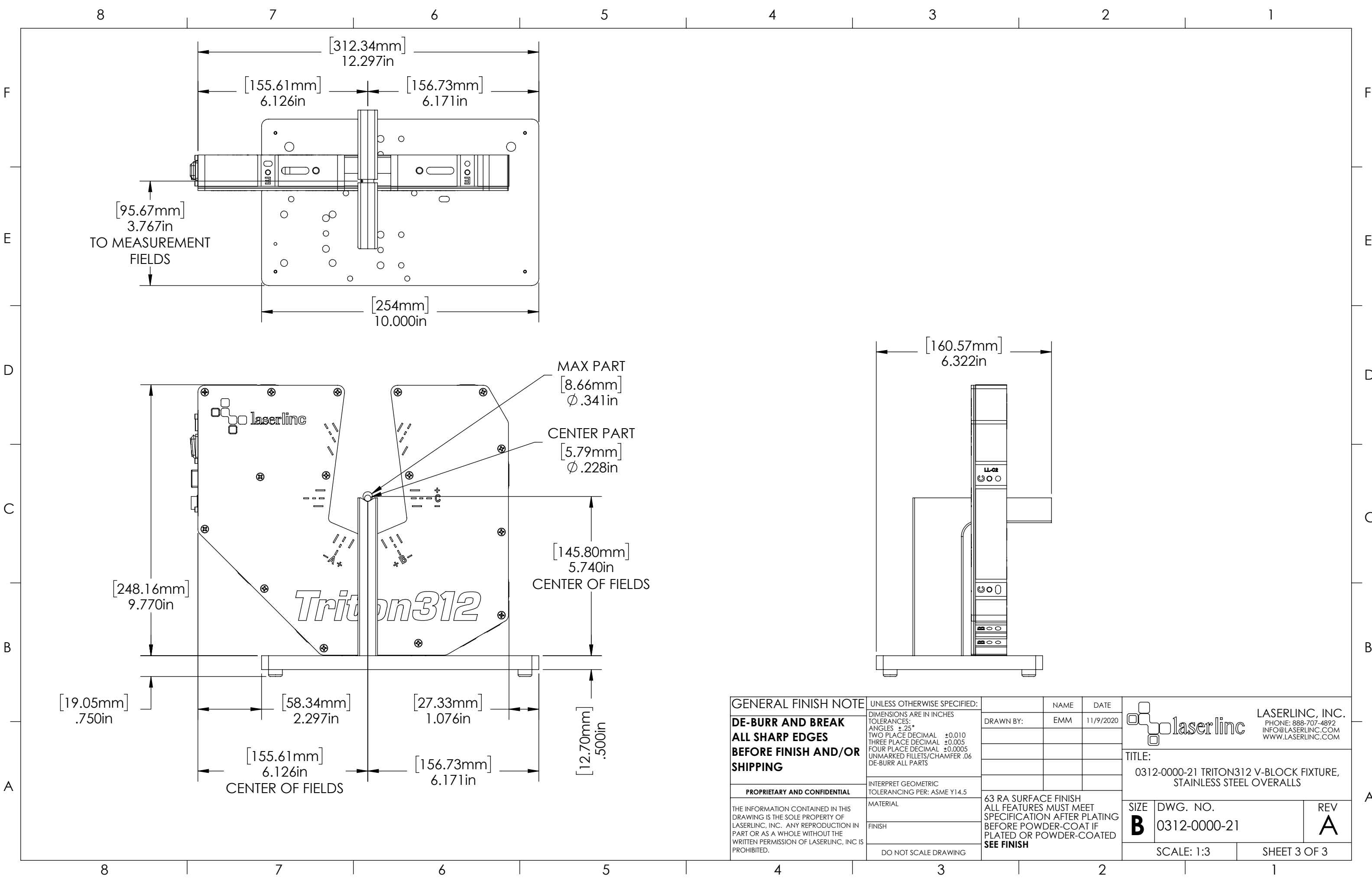

8 7 6 5 4 3 2 1

F
E
D
C
B
A

F
E
D
C
B
A

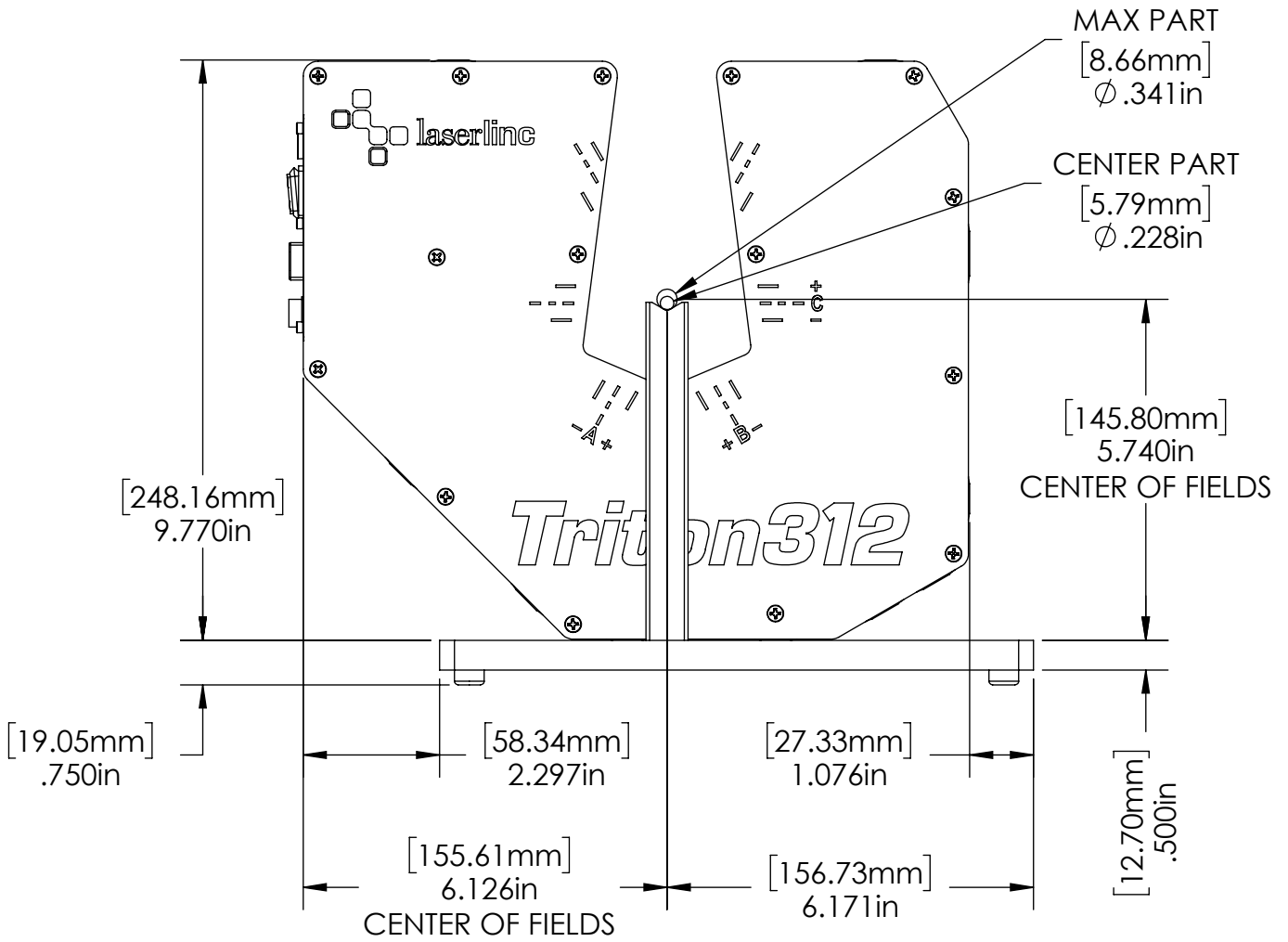
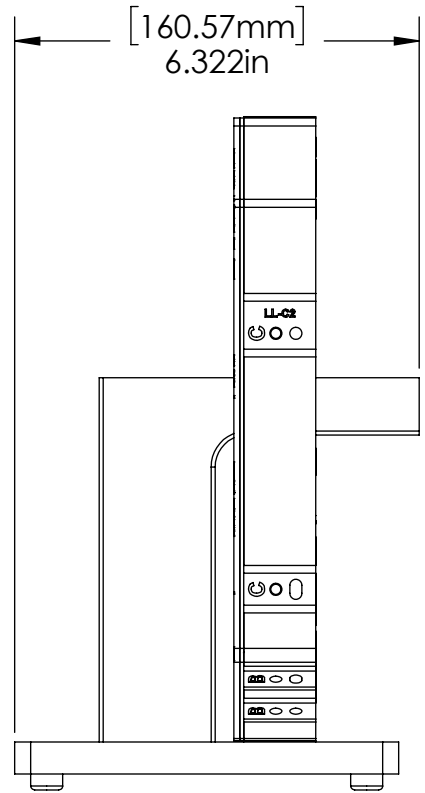
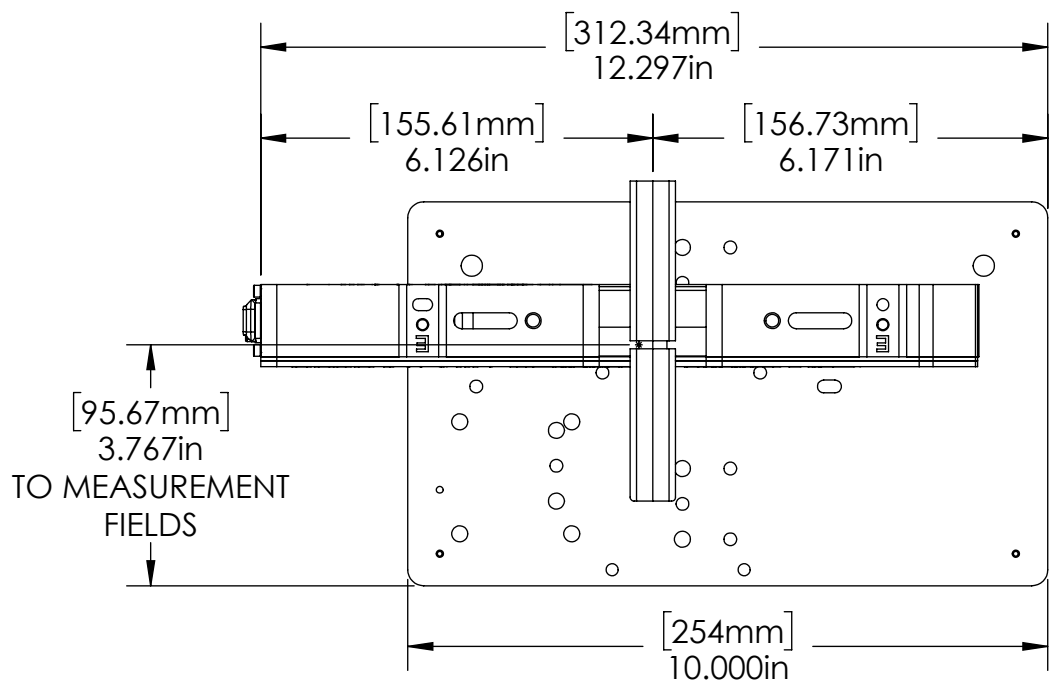

| | | | | | | |
|--|---|---|--|--|--------------------------|-----------------|
| GENERAL FINISH NOTE DE-BURR AND BREAK ALL SHARP EDGES BEFORE FINISH AND/OR SHIPPING | UNLESS OTHERWISE SPECIFIED: DIMENSIONS ARE IN INCHES TOLERANCES: ANGLES ±.25° TWO PLACE DECIMAL ±0.010 THREE PLACE DECIMAL ±0.005 FOUR PLACE DECIMAL ±0.0005 UNMARKED FILLETS/CHAMFER .06 DE-BURR ALL PARTS | NAME DATE |  LASERLINC, INC. PHONE: 888-707-4892 INFO@LASERLINC.COM WWW.LASERLINC.COM | | | |
| | PROPRIETARY AND CONFIDENTIAL THE INFORMATION CONTAINED IN THIS DRAWING IS THE SOLE PROPERTY OF LASERLINC, INC. ANY REPRODUCTION IN PART OR AS A WHOLE WITHOUT THE WRITTEN PERMISSION OF LASERLINC, INC. IS PROHIBITED. | INTERPRET GEOMETRIC TOLERANCING PER: ASME Y14.5 MATERIAL FINISH DO NOT SCALE DRAWING | DRAWN BY: EMM 11/9/2020 | TITLE: 0312-0000-21 TRITON312 V-BLOCK FIXTURE, STAINLESS STEEL OVERALLS | | |
| | | 63 RA SURFACE FINISH ALL FEATURES MUST MEET SPECIFICATION AFTER PLATING BEFORE POWDER-COAT IF PLATED OR POWDER-COATED SEE FINISH | | SIZE B | DWG. NO. 0312-0000-21 | REV A |
| | | SCALE: 1:3 | | SHEET 3 OF 3 | | |

8 7 6 5 4 3 2 1