

8 7 6 5 4 3 2 1

REVISIONS				
ZONE	REV.	DESCRIPTION	DATE	APPROVED
	A	Checked-In	08/28/18	MAM

F  
E  
D  
C  
B  
A

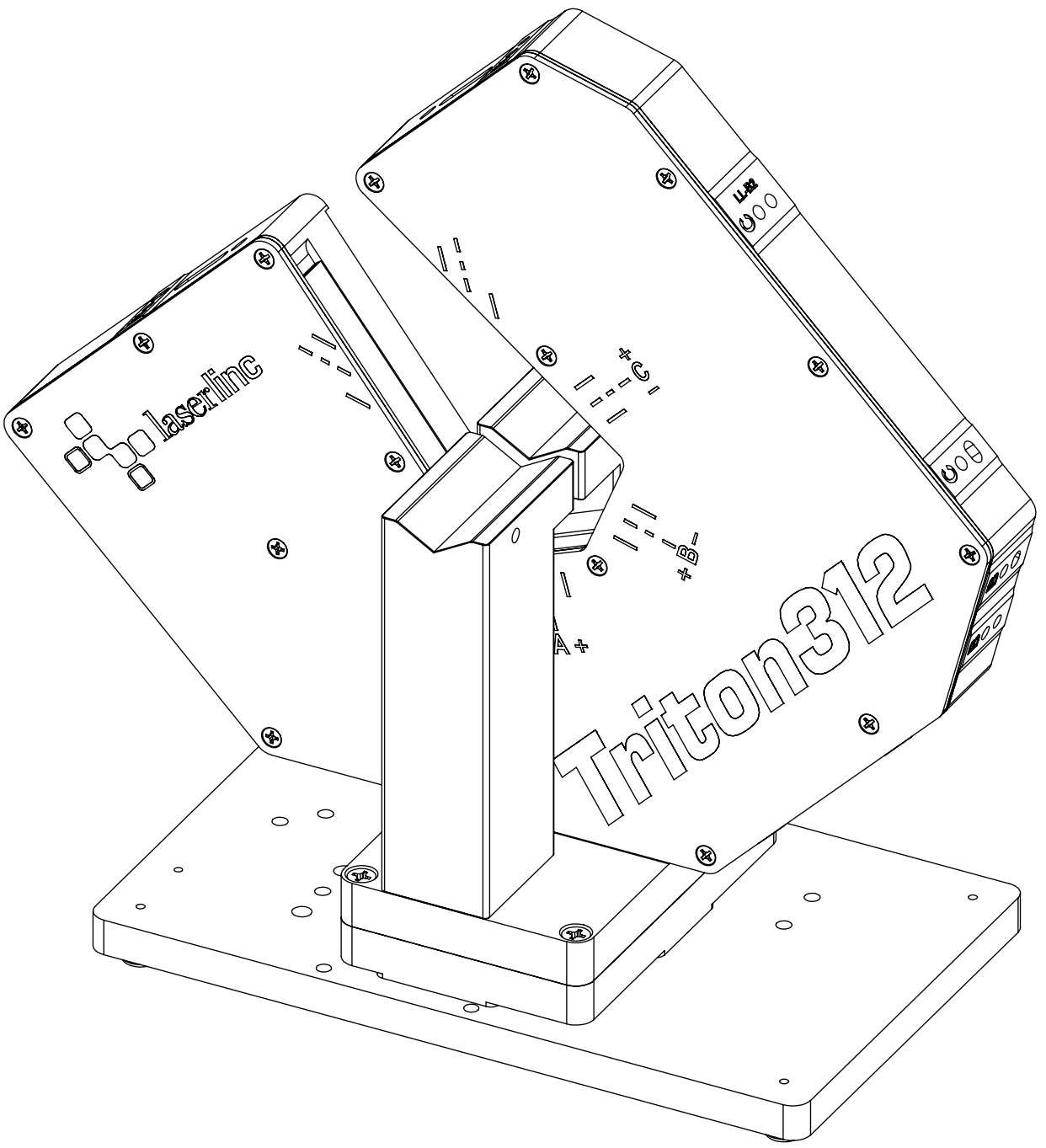

# Fixed V-Block Triton312 Micrometer with Triton330 V-Block

## INDEX

- (1) Cover Page
- (2) Dimensions

<b>GENERAL FINISH NOTE</b> DE-BURR AND BREAK ALL SHARP EDGES BEFORE FINISH AND/OR SHIPPING  PROPRIETARY AND CONFIDENTIAL  THE INFORMATION CONTAINED IN THIS DRAWING IS THE SOLE PROPERTY OF LASERLINC, INC. ANY REPRODUCTION IN PART OR AS A WHOLE WITHOUT THE WRITTEN PERMISSION OF LASERLINC, INC IS PROHIBITED.	UNLESS OTHERWISE SPECIFIED: DIMENSIONS ARE IN INCHES TOLERANCES: ANGULAR: MACH ± BEND ± TWO PLACE DECIMAL ±0.010 THREE PLACE DECIMAL ±0.005 FOUR PLACE DECIMAL ±0.0005 ANGLES ±.25° UNMARKED FILLETS/ROUNDS R.0625 DE-BURR ALL PARTS	NAME MAM DATE 8/28/2018	 LaserLinc, Inc. Phone: 888-707-4892 Info@laserlinc.com www.laserlinc.com	
	INTERPRET GEOMETRIC TOLERANCING PER:  MATERIAL  FINISH  DO NOT SCALE DRAWING	DRAWN BY:   63 RA SURFACE FINISH ALL FEATURES MUST MEET SPECIFICATION AFTER PLATING BEFORE POWDER-COAT IF PLATED OR POWDER-COATED SEE FINISH MACHINE ALL SURFACES		TITLE: 0312-0001-21 Fixed V-Block Triton312 Micrometer with Triton330 V-Block
		SIZE B	DWG. NO. 0312-0001-21	REV A
		SCALE: 1:2	SHEET 1 OF 2	

8 7 6 5 4 3 2 1

F  
E  
D  
C  
B  
A

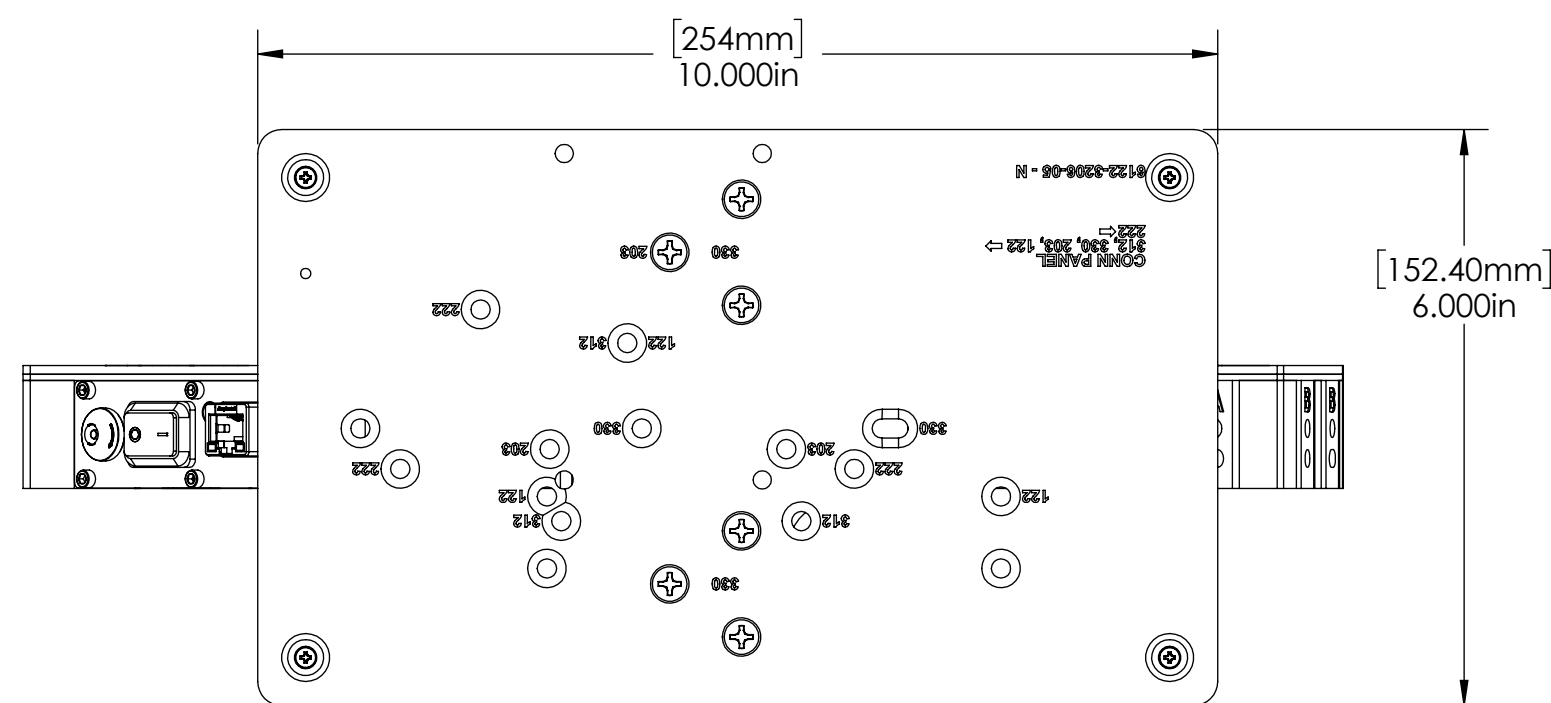
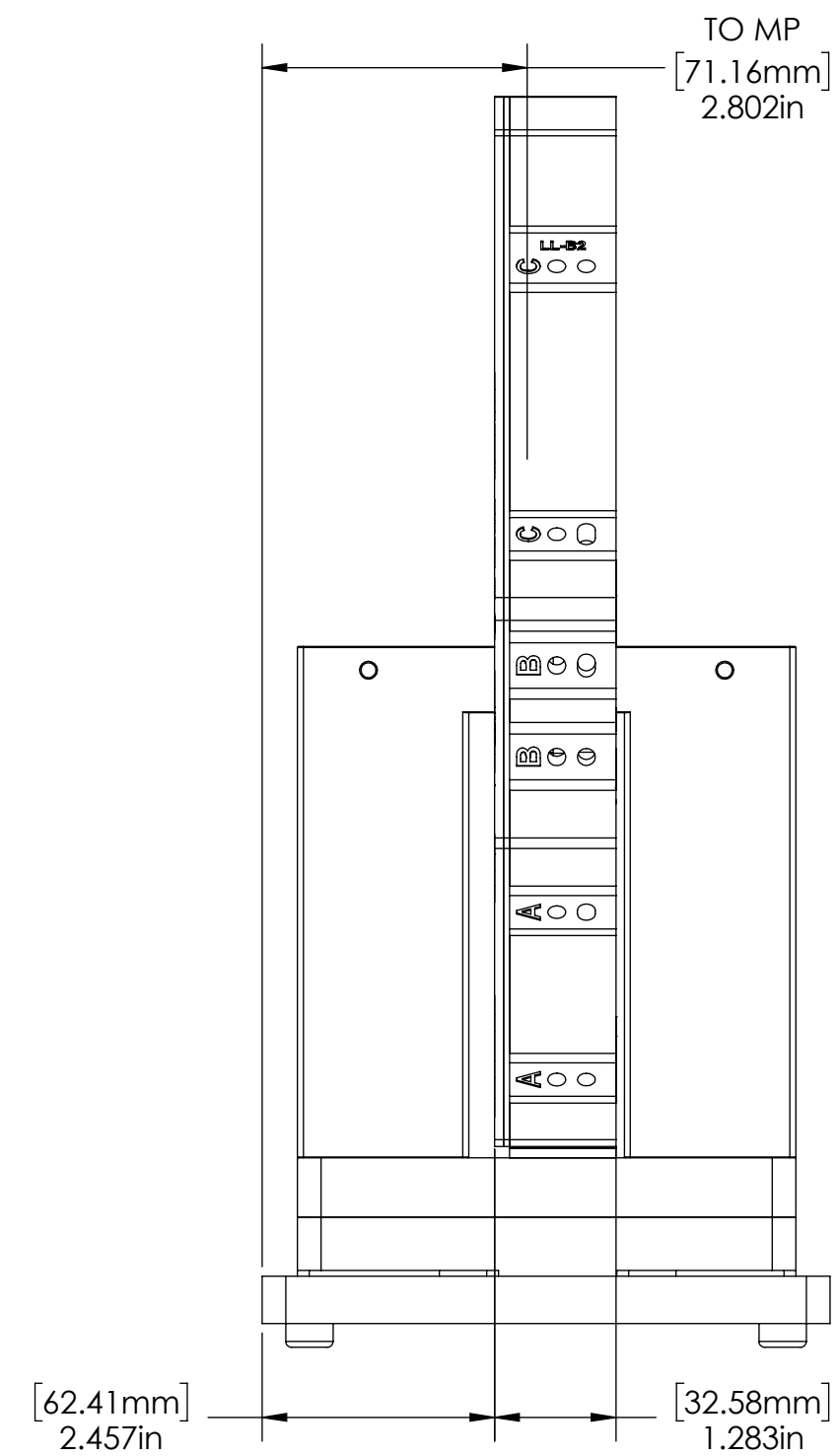
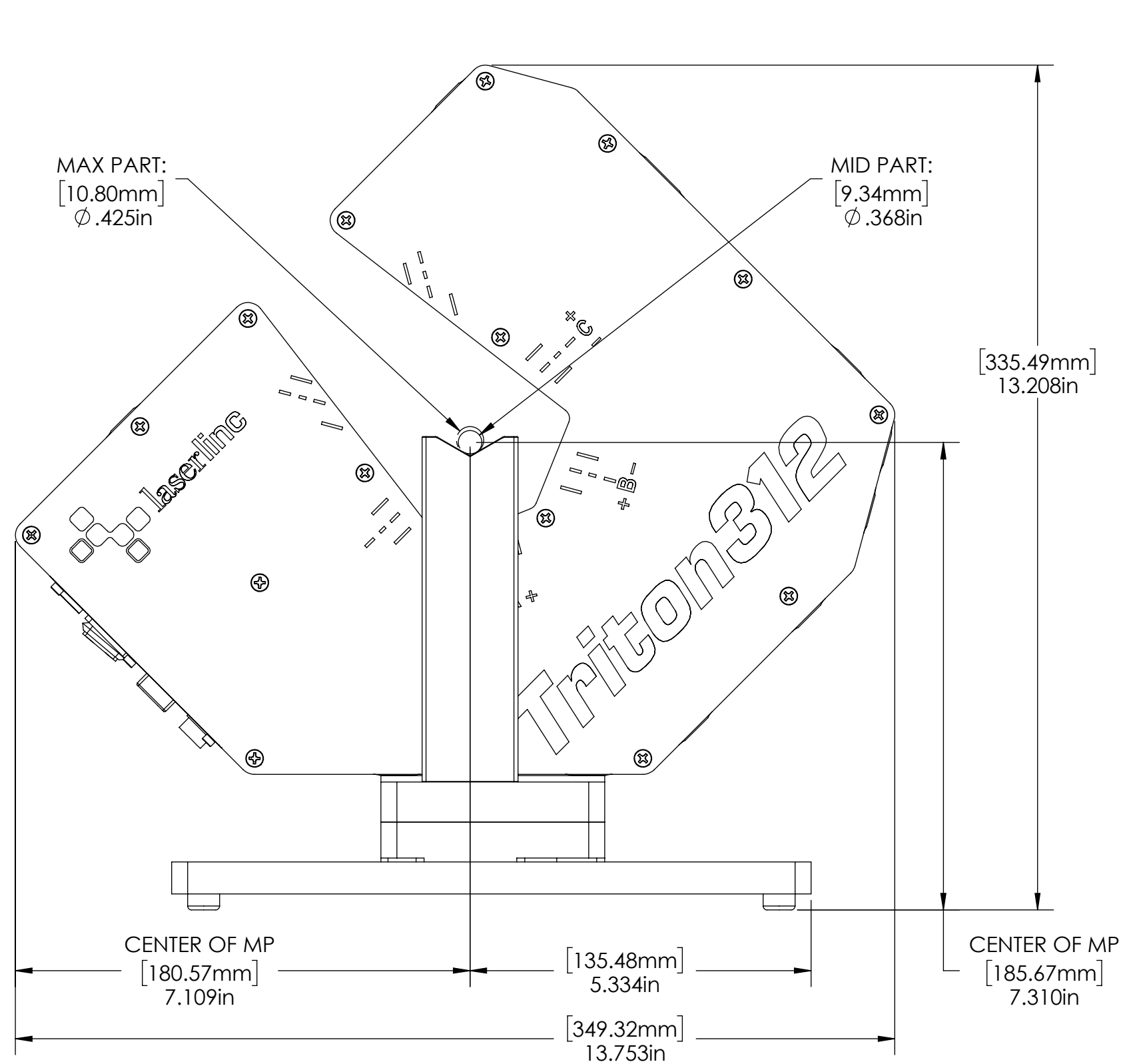

NOTE:  
MP- MEASUREMENT PLANE

GENERAL FINISH NOTE DE-BURR AND BREAK ALL SHARP EDGES BEFORE FINISH AND/OR SHIPPING	UNLESS OTHERWISE SPECIFIED: DIMENSIONS ARE IN INCHES TOLERANCES: ANGULAR: MACH ± BEND ± TWO PLACE DECIMAL: ±0.010 THREE PLACE DECIMAL: ±0.005 FOUR PLACE DECIMAL: ±0.0005 ANGLES: ±.25° UNMARKED FILLETS/ROUNDS R.0625 DE-BURR ALL PARTS	NAME	DATE	LaserLinc, Inc. Phone: 888-707-4892 Info@laserline.com www.laserline.com
	PROPRIETARY AND CONFIDENTIAL	DRAWN BY:	MAM	
THE INFORMATION CONTAINED IN THIS DRAWING IS THE SOLE PROPERTY OF LASERLINC, INC. ANY REPRODUCTION IN PART OR AS A WHOLE WITHOUT THE WRITTEN PERMISSION OF LASERLINC, INC IS PROHIBITED.	INTERPRET GEOMETRIC TOLERANCING PER:	TITLE: 0312-0001-21 Fixed V-Block Triton312 Micrometer with Triton330 V-Block		SIZE C
DO NOT SCALE DRAWING	MATERIAL	63 RA SURFACE FINISH ALL FEATURES MUST MEET SPECIFICATION AFTER PLATING BEFORE POWDER-COAT IF PLATED OR POWDER-COATED SEE FINISH MACHINE ALL SURFACES		DWG. NO. 0312-0001-21
	FINISH	SCALE: 1:2		REV A
		SHEET 2 OF 2		