

8

7

6

5

4

3

2

1

REVISIONS

ZONE	REV.	DESCRIPTION	DATE	APPROVED
	A	Check-In	11/6/2013	MAM

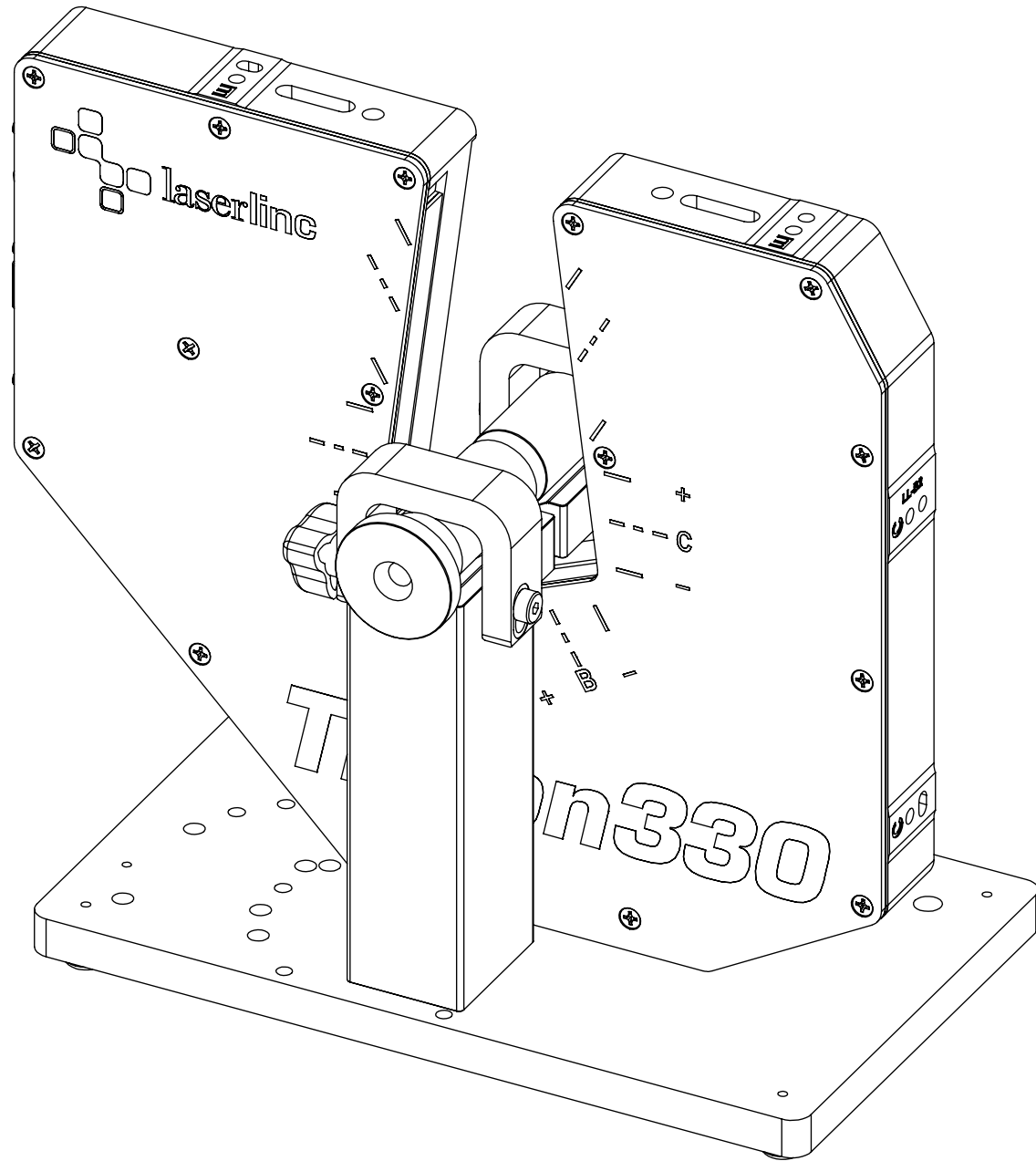

TRITON330 FEED THROUGH ADD-ON OVERALLS

INDEX

- (1) COVER PAGE
- (2) FIXTURE DIMENSIONS
- (3) MOUNTED DIMENSIONS

GENERAL FINISH NOTE		UNLESS OTHERWISE SPECIFIED:		NAME	DATE	 LaserLinc, Inc. Phone: 888-707-4892 info@laserlinc.com www.laserlinc.com
DE-BURR AND BREAK ALL SHARP EDGES BEFORE FINISH AND/OR SHIPPING		DIMENSIONS ARE IN INCHES TOLERANCES: ANGLES ±.25 TWO PLACE DECIMAL ±0.010 THREE PLACE DECIMAL ±0.005 FOUR PLACE DECIMAL ±0.0005 UNMARKED FILLETS/CHAMFER .06 DE-BURR ALL PARTS		DRAWN BY:	EMM	
PROPRIETARY AND CONFIDENTIAL		INTERPRET GEOMETRIC TOLERANCING PER: ASME Y14.5				TITLE: 0330-0000-25 Triton330 Feed Through Add-On Overalls
THE INFORMATION CONTAINED IN THIS DRAWING IS THE SOLE PROPERTY OF LASERLINC, INC. ANY REPRODUCTION IN PART OR AS A WHOLE WITHOUT THE WRITTEN PERMISSION OF LASERLINC, INC. IS PROHIBITED.		MATERIAL		63 RA SURFACE FINISH ALL FEATURES MUST MEET SPECIFICATION AFTER PLATING BEFORE POWDER-COAT IF PLATED OR POWDER-COATED SEE FINISH		SIZE B
		FINISH				DWG. NO. 0330-0000-25
		DO NOT SCALE DRAWING				REV A
				SCALE: 1:2		SHEET 1 OF 3

8

7

6

5

4

3

2

1

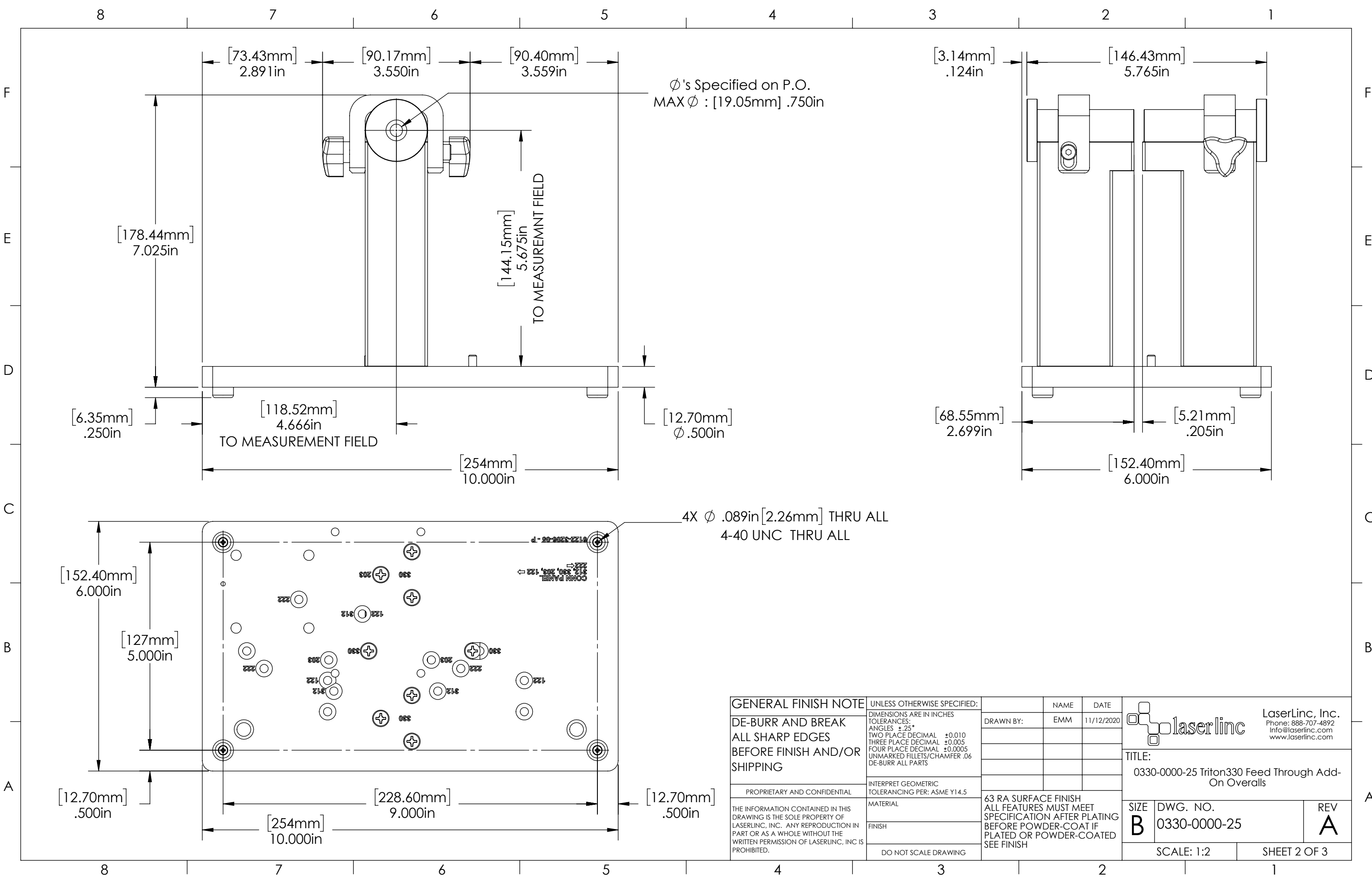

Ø's Specified on P.O.
MAX Ø : [19.05mm] .750in

4X Ø .089in [2.26mm] THRU ALL
4-40 UNC THRU ALL

GENERAL FINISH NOTE DE-BURR AND BREAK ALL SHARP EDGES BEFORE FINISH AND/OR SHIPPING PROPRIETARY AND CONFIDENTIAL THE INFORMATION CONTAINED IN THIS DRAWING IS THE SOLE PROPERTY OF LASERLINC, INC. ANY REPRODUCTION IN PART OR AS A WHOLE WITHOUT THE WRITTEN PERMISSION OF LASERLINC, INC IS PROHIBITED.	UNLESS OTHERWISE SPECIFIED: DIMENSIONS ARE IN INCHES TOLERANCES: ANGLES ±.25 TWO PLACE DECIMAL ±0.010 THREE PLACE DECIMAL ±0.005 FOUR PLACE DECIMAL ±0.0005 UNMARKED FILLETS/CHAMFER .06 DE-BURR ALL PARTS	NAME EMM DATE 11/12/2020	 LaserLinc, Inc. Phone: 888-707-4892 Info@laserlinc.com www.laserlinc.com	
	INTERPRET GEOMETRIC TOLERANCING PER: ASME Y14.5	DRAWN BY: EMM		TITLE: 0330-0000-25 Triton330 Feed Through Add-On Overalls
MATERIAL FINISH DO NOT SCALE DRAWING	63 RA SURFACE FINISH ALL FEATURES MUST MEET SPECIFICATION AFTER PLATING BEFORE POWDER-COAT IF PLATED OR POWDER-COATED SEE FINISH	SIZE B	DWG. NO. 0330-0000-25	REV A
		SCALE: 1:2	SHEET 2 OF 3	

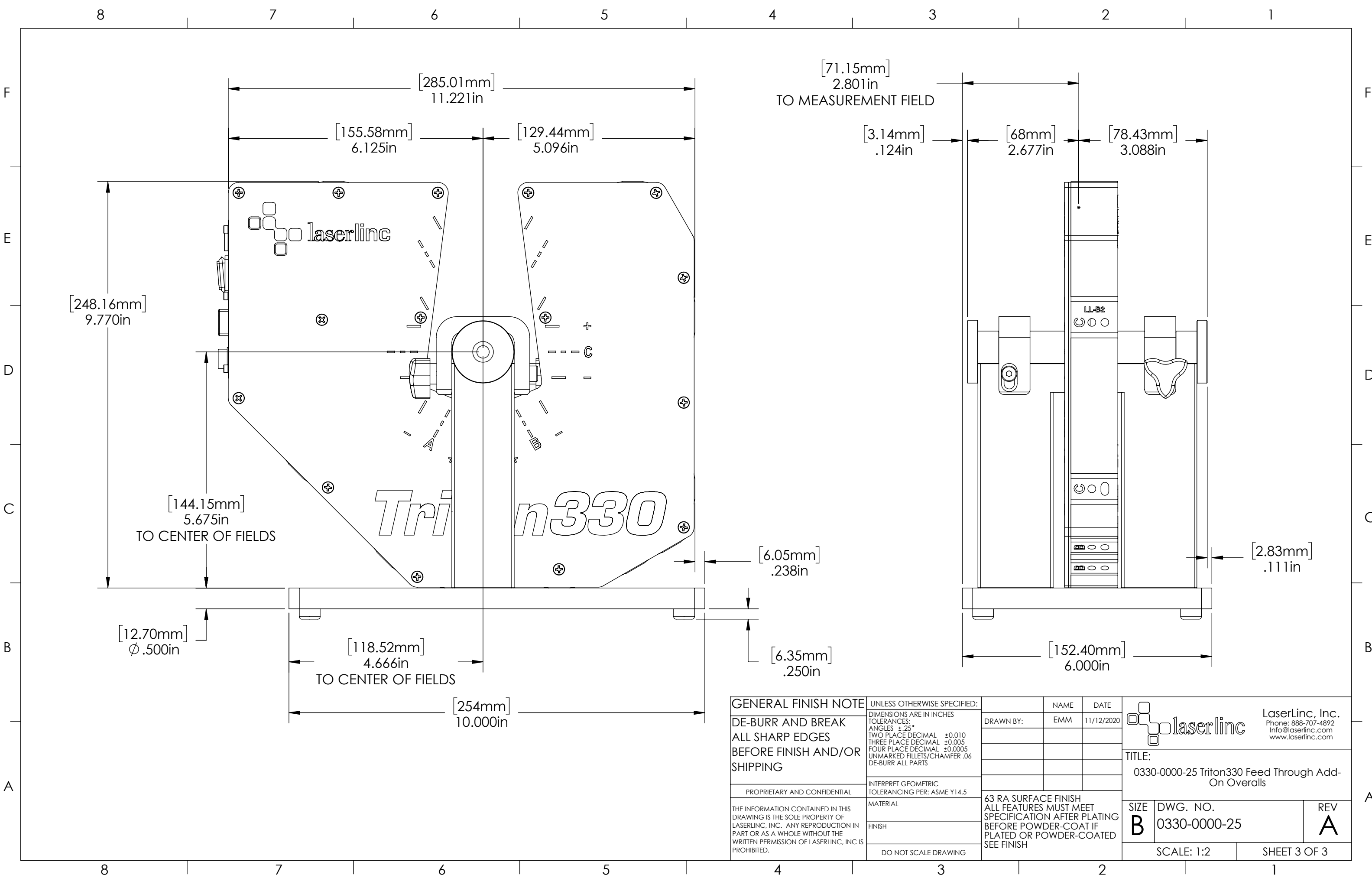

GENERAL FINISH NOTE
 DE-BURR AND BREAK
 ALL SHARP EDGES
 BEFORE FINISH AND/OR
 SHIPPING

UNLESS OTHERWISE SPECIFIED:
 DIMENSIONS ARE IN INCHES
 TOLERANCES:
 ANGLES ±.25°
 TWO PLACE DECIMAL ±0.010
 THREE PLACE DECIMAL ±0.005
 FOUR PLACE DECIMAL ±0.0005
 UNMARKED FILLETS/CHAMFER .06
 DE-BURR ALL PARTS

INTERPRET GEOMETRIC
 TOLERANCING PER: ASME Y14.5

MATERIAL

FINISH

DO NOT SCALE DRAWING

NAME

DATE

DRAWN BY:

EMM

11/12/2020

63 RA SURFACE FINISH
 ALL FEATURES MUST MEET
 SPECIFICATION AFTER PLATING
 BEFORE POWDER-COAT IF
 PLATED OR POWDER-COATED
 SEE FINISH

THE INFORMATION CONTAINED IN THIS
 DRAWING IS THE SOLE PROPERTY OF
 LASERLINC, INC. ANY REPRODUCTION IN
 PART OR AS A WHOLE WITHOUT THE
 WRITTEN PERMISSION OF LASERLINC, INC. IS
 PROHIBITED.

PROPRIETARY AND CONFIDENTIAL

laserlinc LaserLinc, Inc.
 Phone: 888-707-4892
 Info@laserlinc.com
 www.laserlinc.com

TITLE:
 0330-0000-25 Triton330 Feed Through Add-On Overalls

SIZE B	DWG. NO. 0330-0000-25	REV A
SCALE: 1:2		SHEET 3 OF 3