

8

7

6

5

4

3

2

1

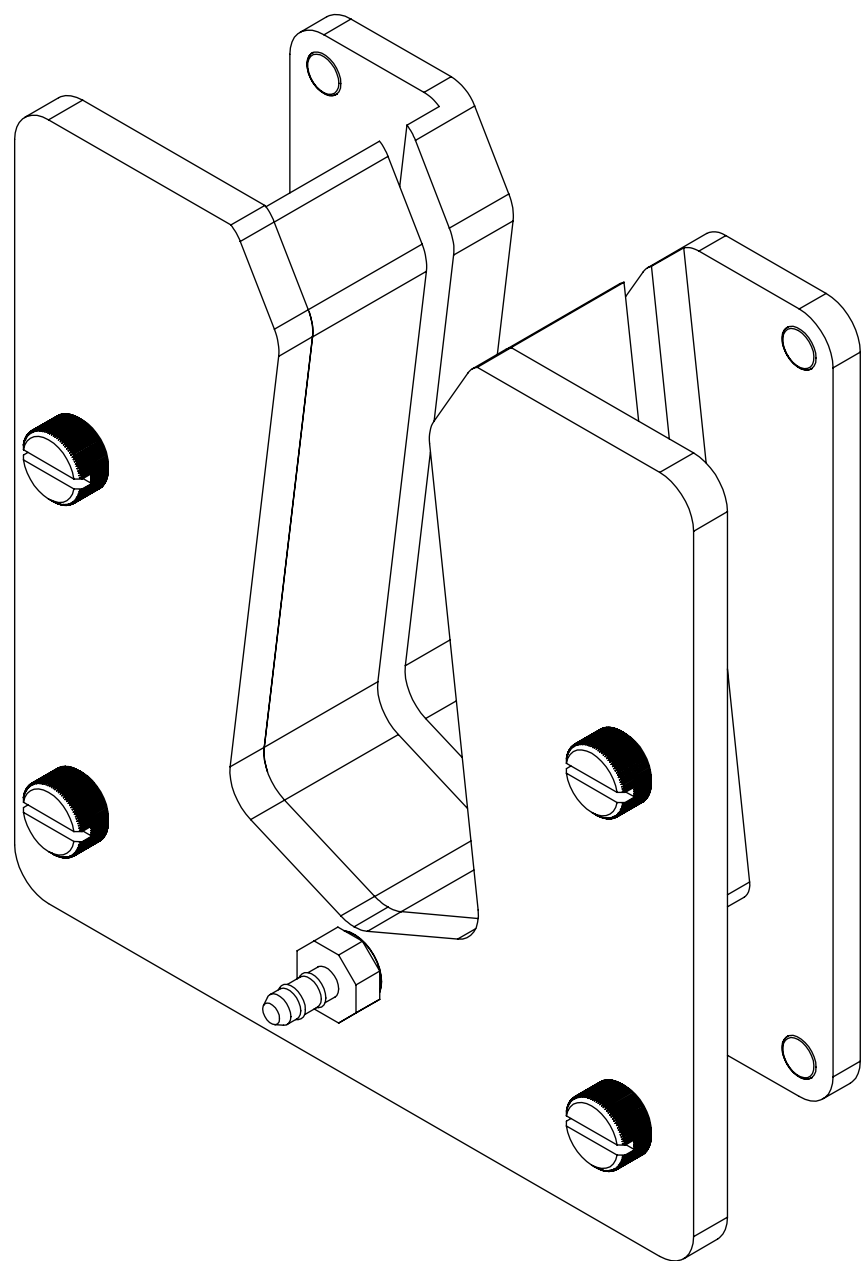

REVISIONS				
ZONE	REV.	DESCRIPTION	DATE	APPROVED
	A	Check-in	5/17/2011	ZRP

# TRITON330/312 AIR PURGE FIXTURE, 2 PEICE OVERALLS

## INDEX

- (1) COVER PAGE
- (2) AIR PURGE DIMENSIONS
- (3) GAUGE MOUNTED DIMENSIONS

<b>GENERAL FINISH NOTE</b> DE-BURR AND BREAK ALL SHARP EDGES BEFORE FINISH AND/OR SHIPPING  PROPRIETARY AND CONFIDENTIAL  THE INFORMATION CONTAINED IN THIS DRAWING IS THE SOLE PROPERTY OF LASERLINC, INC. ANY REPRODUCTION IN PART OR AS A WHOLE WITHOUT THE WRITTEN PERMISSION OF LASERLINC, INC. IS PROHIBITED.	UNLESS OTHERWISE SPECIFIED: DIMENSIONS ARE IN INCHES TOLERANCES: ANGLES ±.25° TWO PLACE DECIMAL ±0.010 THREE PLACE DECIMAL ±0.005 FOUR PLACE DECIMAL ±0.0005 UNMARKED FILLETS/CHAMFER .06 DE-BURR ALL PARTS	NAME EMM	DATE 11/20/2020	 <b>LASERLINC, INC.</b> PHONE: 888-707-4892 INFO@LASERLINC.COM WWW.LASERLINC.COM
	INTERPRET GEOMETRIC TOLERANCING PER: ASME Y14.5	DRAWN BY:	TITLE: 0300-0000-30 TRITON330-312 AIR PURGE FIXTURE, 2 PEICE OVERALLS	
MATERIAL  FINISH  DO NOT SCALE DRAWING	63 RA SURFACE FINISH ALL FEATURES MUST MEET SPECIFICATION AFTER PLATING BEFORE POWDER-COAT IF PLATED OR POWDER-COATED SEE FINISH	SIZE <b>B</b>	DWG. NO. 0300-0000-30	REV <b>A</b>
		SCALE: 1:1	SHEET 1 OF 3	

8

7

6

5

4

3

2

1

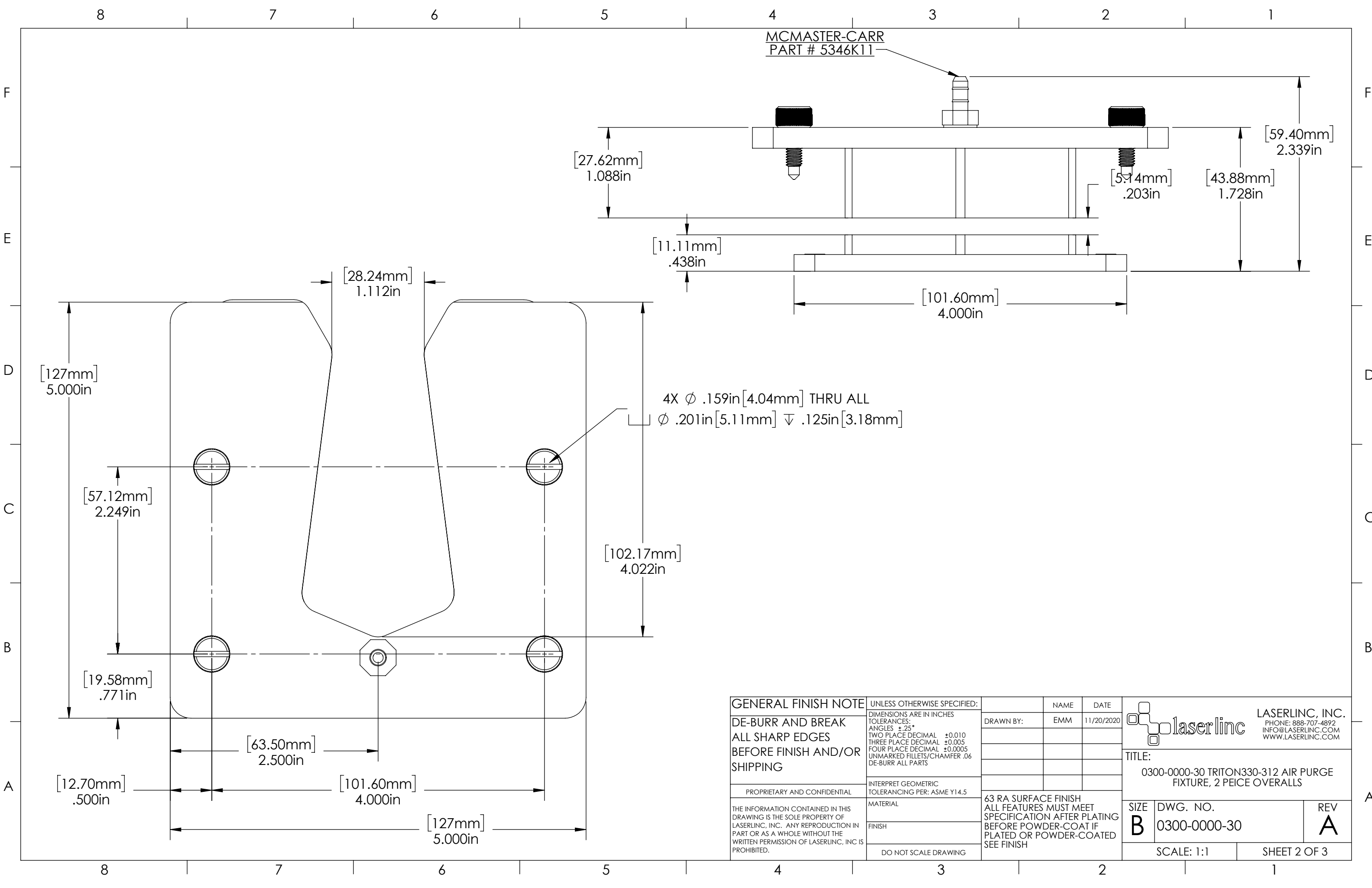

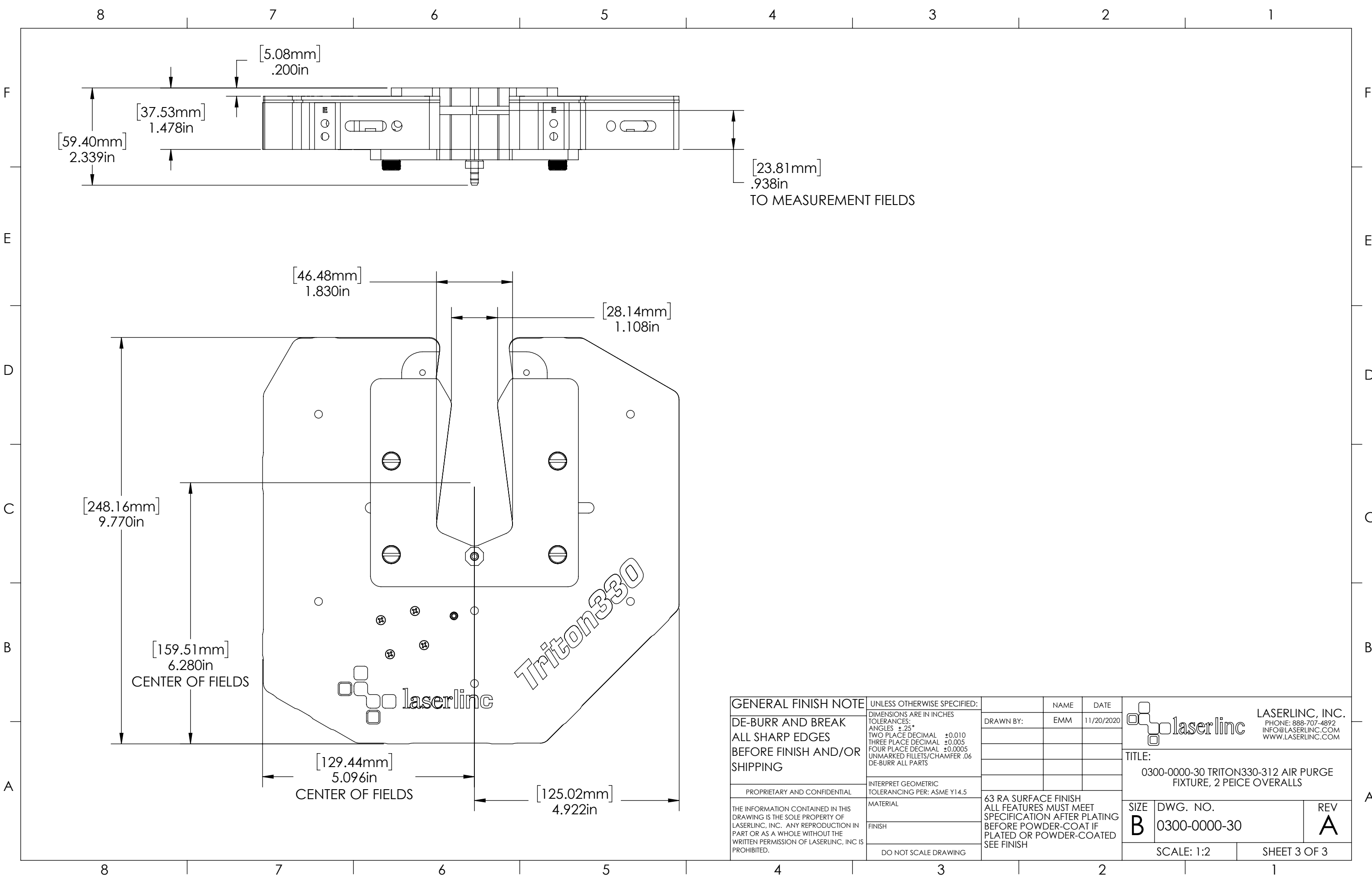

GENERAL FINISH NOTE	UNLESS OTHERWISE SPECIFIED:	NAME	DATE	 <b>LASERLINC, INC.</b> PHONE: 888-707-4892 INFO@LASERLINC.COM WWW.LASERLINC.COM
	DIMENSIONS ARE IN INCHES TOLERANCES: ANGLES ±.25° TWO PLACE DECIMAL ±0.010 THREE PLACE DECIMAL ±0.005 FOUR PLACE DECIMAL ±0.0005 UNMARKED FILLETS/CHAMFER .06 DE-BURR ALL PARTS	DRAWN BY:	EMM	
DE-BURR AND BREAK ALL SHARP EDGES BEFORE FINISH AND/OR SHIPPING	INTERPRET GEOMETRIC TOLERANCING PER: ASME Y14.5	TITLE: 0300-0000-30 TRITON330-312 AIR PURGE FIXTURE, 2 PEICE OVERALLS		SIZE <b>B</b> DWG. NO. 0300-0000-30 REV <b>A</b>
PROPRIETARY AND CONFIDENTIAL  THE INFORMATION CONTAINED IN THIS DRAWING IS THE SOLE PROPERTY OF LASERLINC, INC. ANY REPRODUCTION IN PART OR AS A WHOLE WITHOUT THE WRITTEN PERMISSION OF LASERLINC, INC IS PROHIBITED.	MATERIAL  FINISH  DO NOT SCALE DRAWING	63 RA SURFACE FINISH ALL FEATURES MUST MEET SPECIFICATION AFTER PLATING BEFORE POWDER-COAT IF PLATED OR POWDER-COATED SEE FINISH		