

REVISIONS

ZONE	REV.	DESCRIPTION	DATE	APPROVED
	A	CHECK-IN	09/20/18	MAM

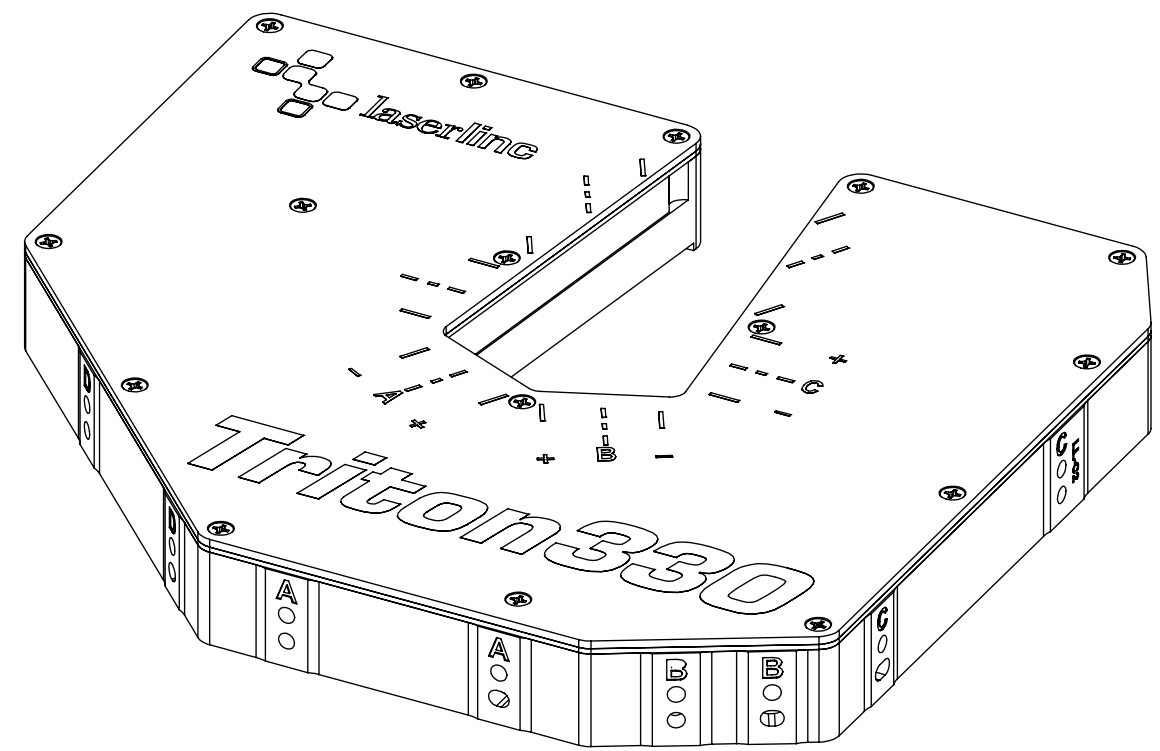

# TRITON330 TRIPLE-AXIS NETLINC MICROMETER OVERALL DIMENSIONS

NOTES:

- APPROX. WEIGHT: 8.5LBS [3.9KG]
- POWER REQUIREMENTS: 12VDC 125MA, +5VDC 75MA, -5VDC 50MA
- MEASUREMENTS PER SECOND (Hz): 900 [300 PER AXIS]
- RESOLUTION: .000001" [.025µm]
- REPEATABILITY<sup>2</sup> UNAVERAGED: ±.0001" [±2.5µm]
- REPEATABILITY<sup>2</sup> TWO SECOND: ±.000005" [±.125µm]

## INDEX

- (1) COVER PAGE
- (2) BACK & A-MOUNTING DIMENSIONS
- (3) B-MOUNTING DIMENSIONS
- (4) C-MOUNTING DIMENSIONS
- (5) D-MOUNTING DIMENSIONS
- (6) E-MOUNTING DIMENSIONS

GENERAL FINISH NOTE		UNLESS OTHERWISE SPECIFIED:		NAME	DATE	 LaserLinc, Inc. Phone: 888-707-4892 Info@laserline.com www.laserline.com
DE-BURR AND BREAK ALL SHARP EDGES BEFORE FINISH AND/OR SHIPPING		DIMENSIONS ARE IN MILLIMETERS TOLERANCES: ANGULAR: MACH ± BEND ± TWO PLACE DECIMAL ±0.25 THREE PLACE DECIMAL ±0.125 FOUR PLACE DECIMAL ±0.0125 ANGLES ±.25° UNMARKED FILLETS/ROUNDS R1.588 DE-BURR ALL PARTS		DRAWN BY:	MAM	
PROPRIETARY AND CONFIDENTIAL		INTERPRET GEOMETRIC TOLERANCING PER:				TITLE: 0330-0002-00 Triton330 Triple-Axis NetLinc Micrometer Overall Mount Dimensions
THE INFORMATION CONTAINED IN THIS DRAWING IS THE SOLE PROPERTY OF LASERLINC, INC. ANY REPRODUCTION IN PART OR AS A WHOLE WITHOUT THE WRITTEN PERMISSION OF LASERLINC, INC IS PROHIBITED.		MATERIAL		63 RA SURFACE FINISH ALL FEATURES MUST MEET SPECIFICATION AFTER PLATING BEFORE POWDER-COAT IF PLATED OR POWDER-COATED SEE FINISH MACHINE ALL SURFACES		SIZE B
		FINISH		DO NOT SCALE DRAWING		DWG. NO. 0330-0002-00
						REV A
						SCALE: 1:2
						SHEET 1 OF 6

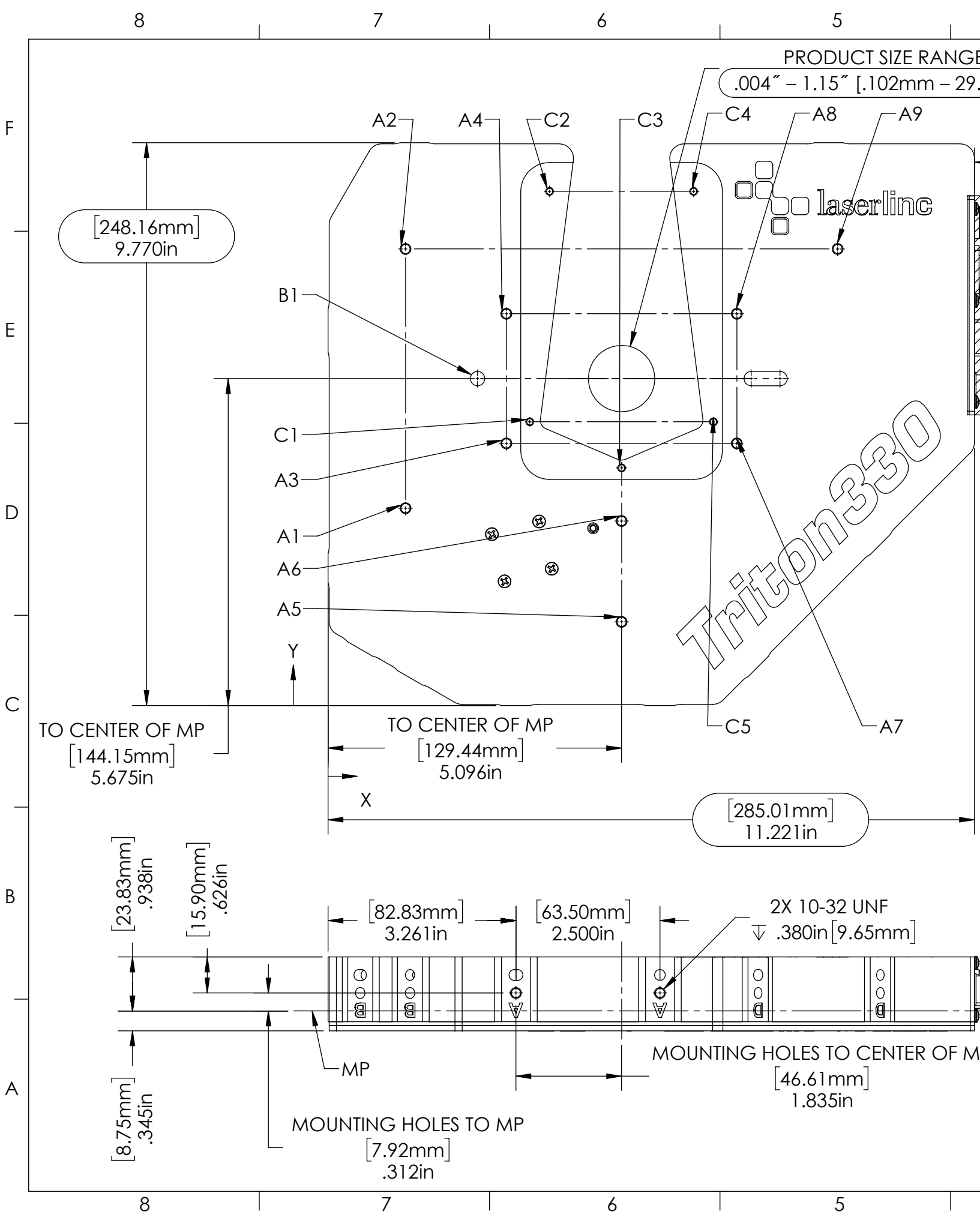

PRODUCT SIZE RANGE  
 .004" - 1.15" [.102mm - 29.2mm]

[50.80mm]  
 2.000in

MIN. CABLE  
 SPACE REQUIRED

[248.16mm]  
 9.770in

TO CENTER OF MP  
 [144.15mm]  
 5.675in

TO CENTER OF MP  
 [129.44mm]  
 5.096in

[285.01mm]  
 11.221in

[23.83mm]  
 .938in

[15.90mm]  
 .626in

[82.83mm]  
 3.261in

[63.50mm]  
 2.500in

2X 10-32 UNF  
 ∇ .380in [9.65mm]

MOUNTING HOLES TO CENTER OF MP  
 [46.61mm]  
 1.835in

MOUNTING HOLES TO MP  
 [7.92mm]  
 .312in

[8.75mm]  
 .345in

TAG	X LOC	Y LOC	SIZE
A1	1.346in	3.425in	$\phi$ .159in ∇ .470in 10-32 UNF ∇ .380in
A2	1.346in	7.925in	
A3	3.096in	4.550in	
A4	3.096in	6.800in	
A5	5.096in	1.452in	
A6	5.096in	3.202in	
A7	7.096in	4.550in	
A8	7.096in	6.800in	
A9	8.846in	7.925in	
B1	2.596in	5.675in	$\phi$ .251in <sup>+.001</sup> <sub>-.000</sub> ∇ .375in
C1	3.502in	4.925in	$\phi$ .107in ∇ .600in 6-32 UNC ∇ .500in
C2	3.846in	8.925in	
C3	5.096in	4.125in	
C4	6.346in	8.925in	
C5	6.690in	4.925in	

NOTES:  
 • MP = MEASUREMENT PLANE

<b>GENERAL FINISH NOTE</b> DE-BURR AND BREAK ALL SHARP EDGES BEFORE FINISH AND/OR SHIPPING	UNLESS OTHERWISE SPECIFIED:	NAME	DATE	 LaserLinc, Inc. Phone: 888-707-4892 Info@laserlinc.com www.laserlinc.com	
	DIMENSIONS ARE IN MILLIMETERS TOLERANCES: ANGULAR: MACH ± BEND ± TWO PLACE DECIMAL ±0.25 THREE PLACE DECIMAL ±0.125 FOUR PLACE DECIMAL ±0.0125 ANGLES ±.25° UNMARKED FILLETS/ROUNDS R1.588 DE-BURR ALL PARTS	DRAWN BY:	MAM		9/20/2018
	INTERPRET GEOMETRIC TOLERANCING PER:				
	MATERIAL				
THE INFORMATION CONTAINED IN THIS DRAWING IS THE SOLE PROPERTY OF LASERLINC, INC. ANY REPRODUCTION IN PART OR AS A WHOLE WITHOUT THE WRITTEN PERMISSION OF LASERLINC, INC. IS PROHIBITED.	FINISH	63 RA SURFACE FINISH ALL FEATURES MUST MEET SPECIFICATION AFTER PLATING BEFORE POWDER-COAT IF PLATED OR POWDER-COATED SEE FINISH MACHINE ALL SURFACES		TITLE: 0330-0002-00 Triton330 Triple-Axis NetLinc Micrometer Overall Mount Dimensions	
DO NOT SCALE DRAWING		SIZE	DWG. NO.	REV	
		B	0330-0002-00	A	
		SCALE: 1:2		SHEET 2 OF 6	

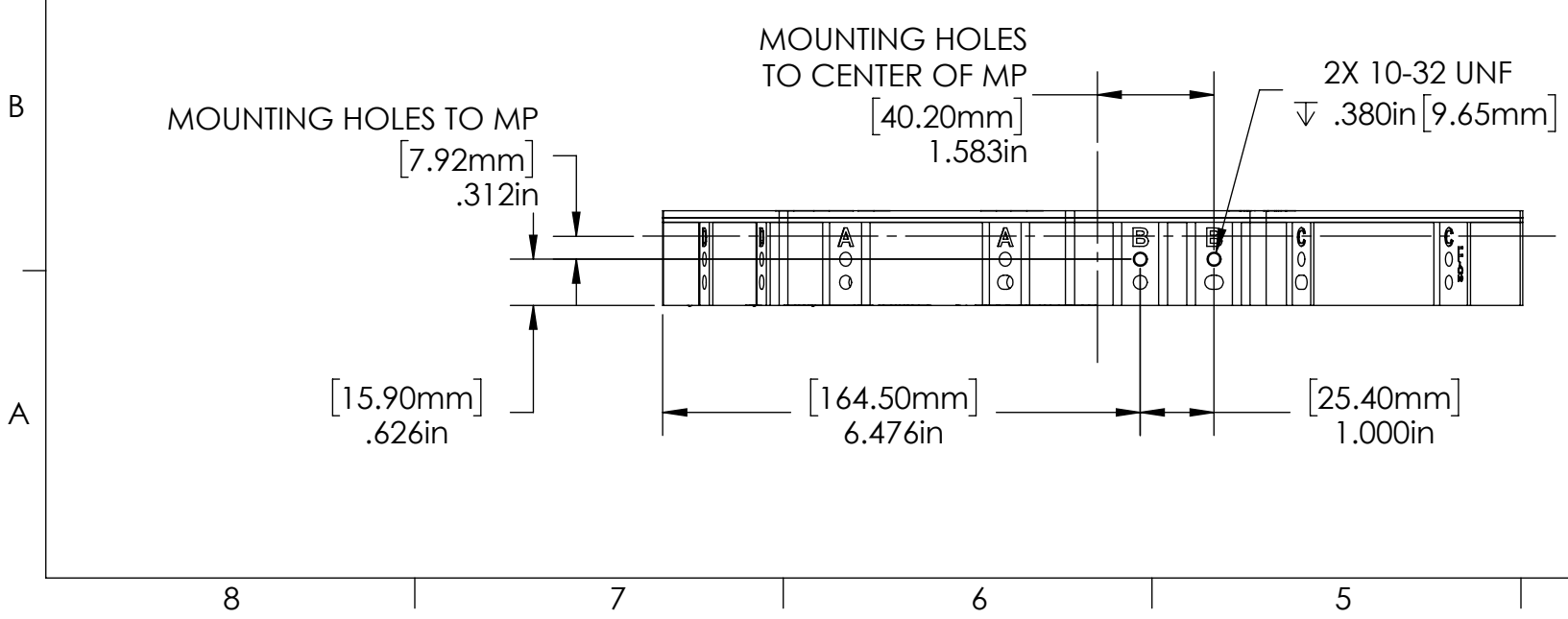
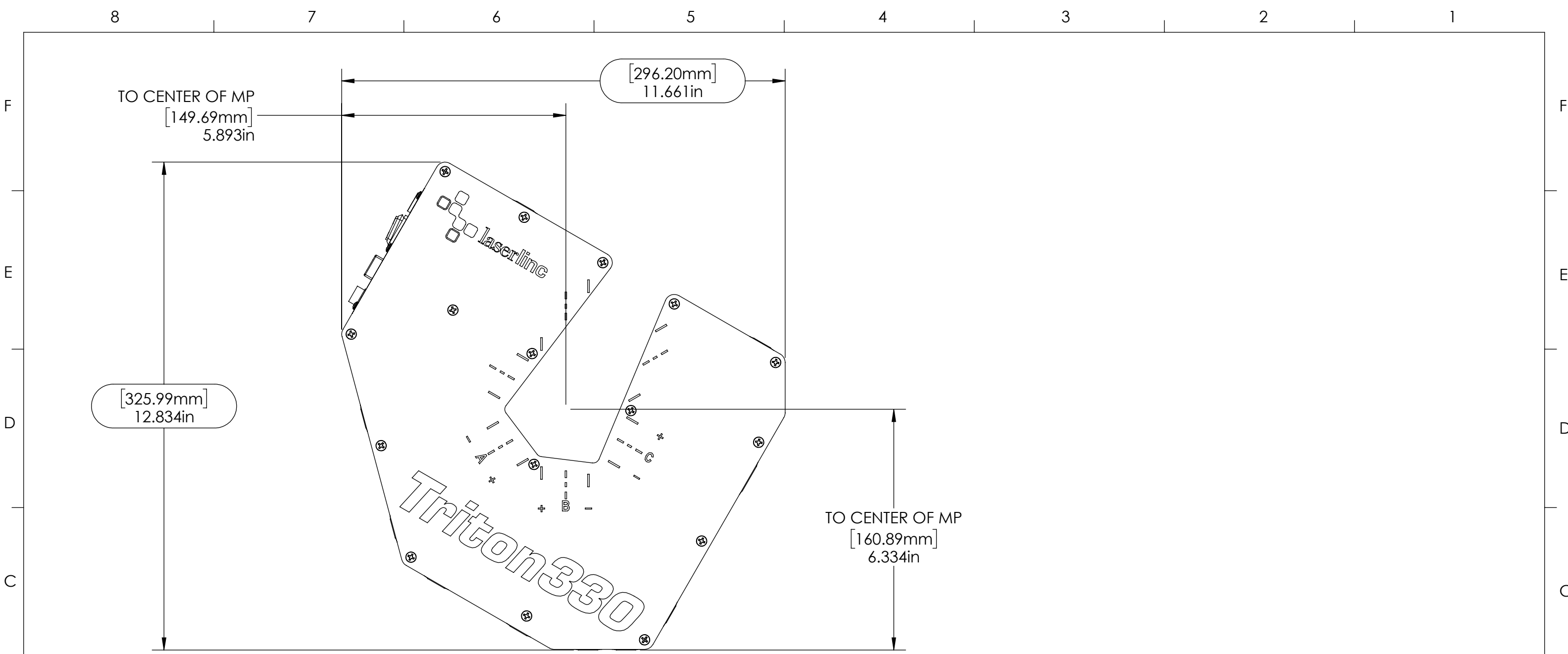

**NOTES:**  
 • MP = MEASUREMENT PLANE

**GENERAL FINISH NOTE**  
 DE-BURR AND BREAK ALL SHARP EDGES BEFORE FINISH AND/OR SHIPPING

PROPRIETARY AND CONFIDENTIAL

THE INFORMATION CONTAINED IN THIS DRAWING IS THE SOLE PROPERTY OF LASERLINC, INC. ANY REPRODUCTION IN PART OR AS A WHOLE WITHOUT THE WRITTEN PERMISSION OF LASERLINC, INC. IS PROHIBITED.

UNLESS OTHERWISE SPECIFIED:  
 DIMENSIONS ARE IN MILLIMETERS  
 TOLERANCES:  
 ANGULAR: MACH ± BEND ±  
 TWO PLACE DECIMAL ±0.25  
 THREE PLACE DECIMAL ±0.125  
 FOUR PLACE DECIMAL ±0.0125  
 ANGLES ±.25°  
 UNMARKED FILLETS/ROUNDS R1.588  
 DE-BURR ALL PARTS

INTERPRET GEOMETRIC TOLERANCING PER:  
 MATERIAL  
 FINISH  
 DO NOT SCALE DRAWING

NAME	DATE
MAM	9/20/2018
DRAWN BY:	
63 RA SURFACE FINISH ALL FEATURES MUST MEET SPECIFICATION AFTER PLATING BEFORE POWDER-COAT IF PLATED OR POWDER-COATED SEE FINISH MACHINE ALL SURFACES	

 LaserLinc, Inc. Phone: 888-707-4892 Info@laserlinc.com www.laserlinc.com		TITLE:	
		0330-0002-00 Triton330 Triple-Axis NetLinc Micrometer Overall Mount Dimensions	
SIZE	DWG. NO.	REV	
B	0330-0002-00	A	
SCALE: 2:5		SHEET 3 OF 6	

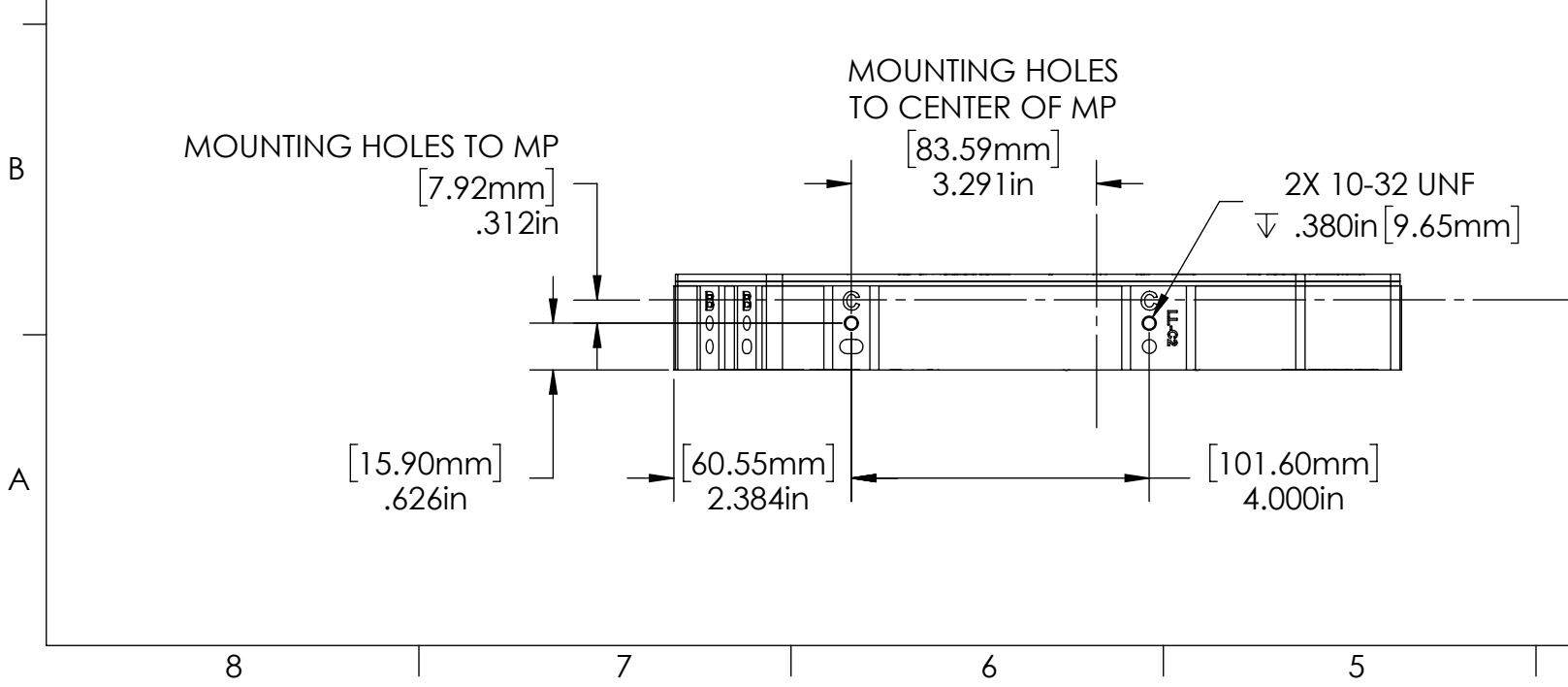
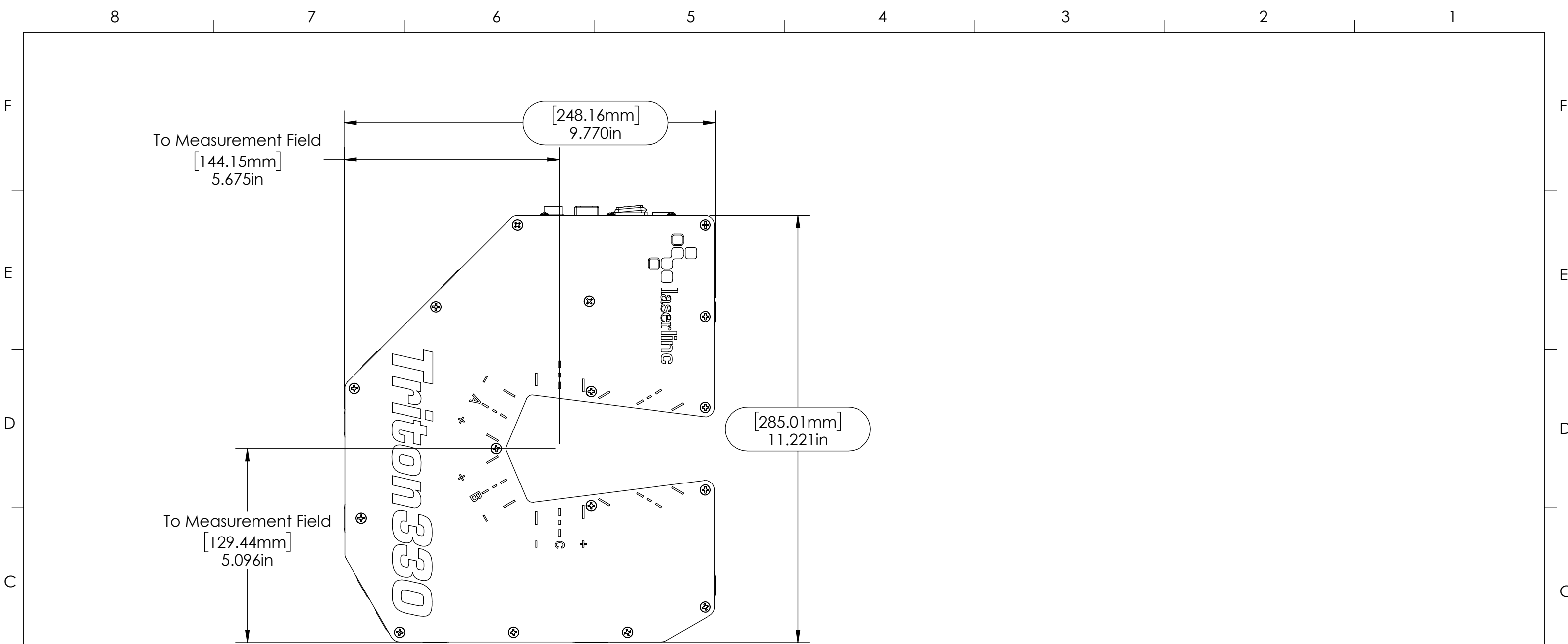

**NOTES:**

- MP = MEASUREMENT PLANE

<b>GENERAL FINISH NOTE</b> DE-BURR AND BREAK ALL SHARP EDGES BEFORE FINISH AND/OR SHIPPING	UNLESS OTHERWISE SPECIFIED: DIMENSIONS ARE IN MILLIMETERS TOLERANCES: ANGULAR: MACH ± BEND ± TWO PLACE DECIMAL ±0.25 THREE PLACE DECIMAL ±0.125 FOUR PLACE DECIMAL ±0.0125 ANGLES ±.25° UNMARKED FILLETS/ROUNDS R1.588 DE-BURR ALL PARTS	NAME DATE	 LaserLinc, Inc. Phone: 888-707-4892 Info@laserline.com www.laserline.com	
	INTERPRET GEOMETRIC TOLERANCING PER: MATERIAL FINISH DO NOT SCALE DRAWING	DRAWN BY: MAM 9/20/2018		TITLE: 0330-0002-00 Triton330 Triple-Axis NetLinc Micrometer Overall Mount Dimensions
PROPRIETARY AND CONFIDENTIAL  THE INFORMATION CONTAINED IN THIS DRAWING IS THE SOLE PROPERTY OF LASERLINC, INC. ANY REPRODUCTION IN PART OR AS A WHOLE WITHOUT THE WRITTEN PERMISSION OF LASERLINC, INC. IS PROHIBITED.	63 RA SURFACE FINISH ALL FEATURES MUST MEET SPECIFICATION AFTER PLATING BEFORE POWDER-COAT IF PLATED OR POWDER-COATED SEE FINISH MACHINE ALL SURFACES	SIZE <b>B</b>	DWG. NO. 0330-0002-00	REV <b>A</b>
		SCALE: 2:5	SHEET 4 OF 6	

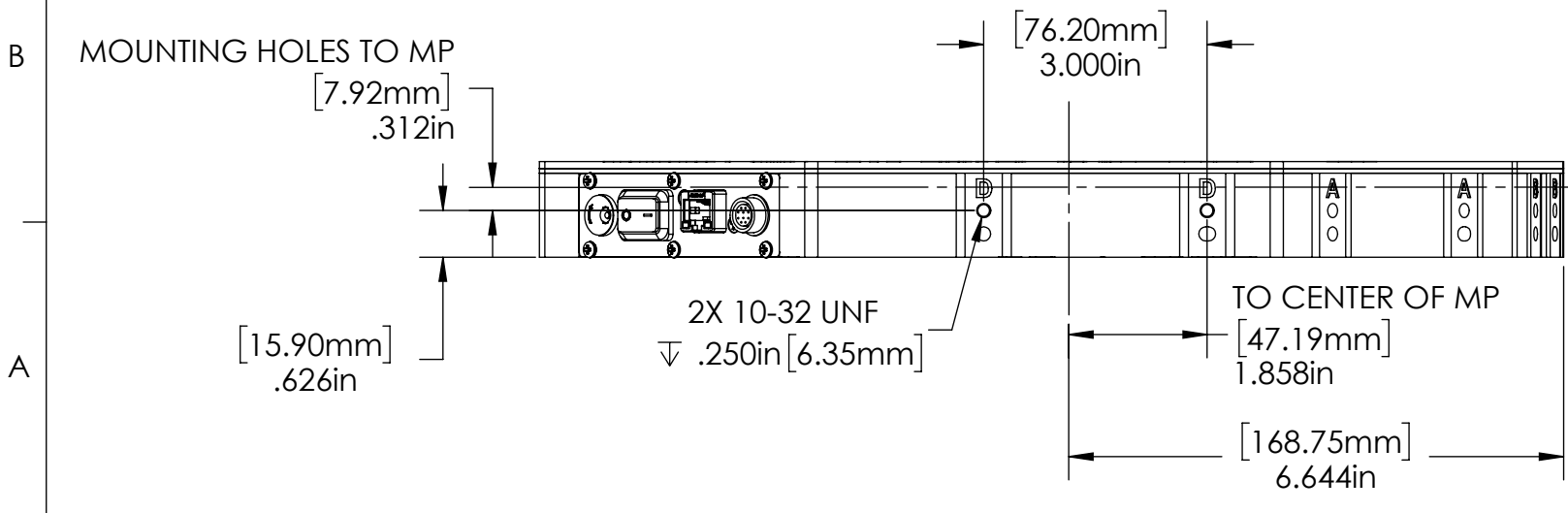
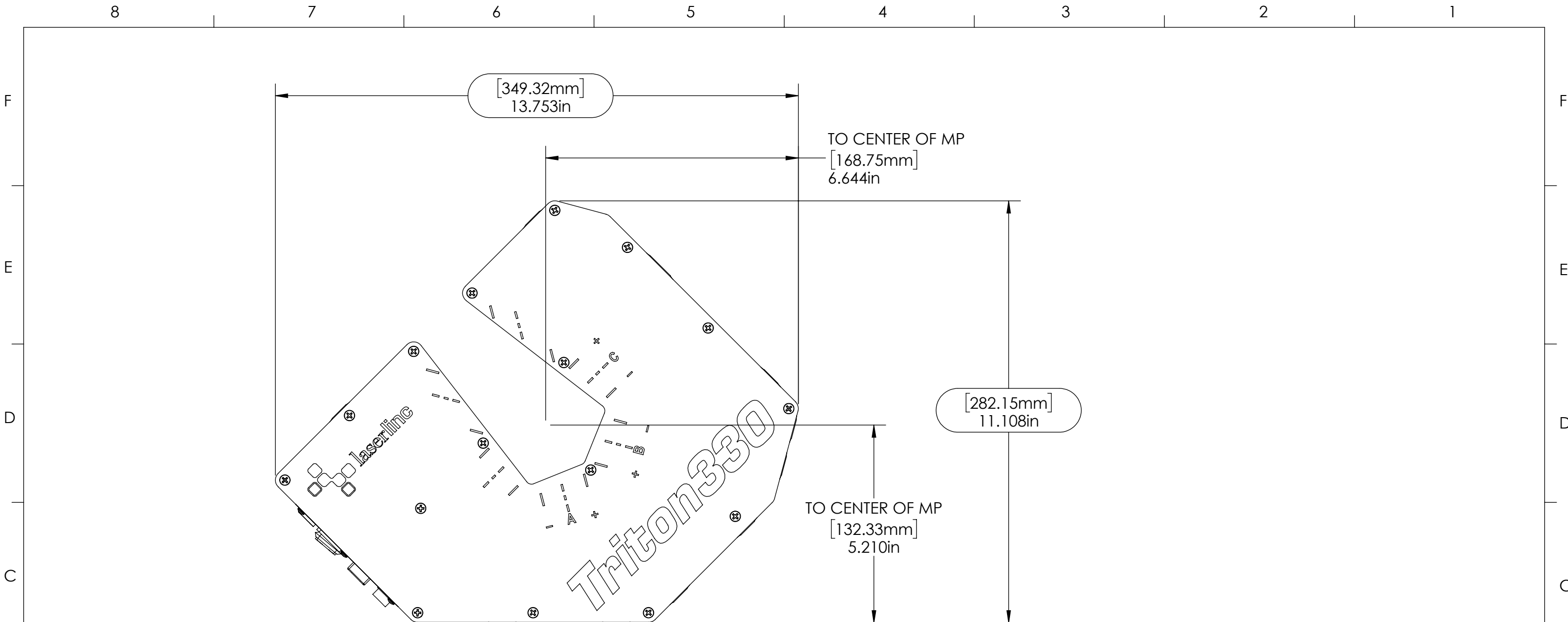

**NOTES:**  
 • MP = MEASUREMENT PLANE

<b>GENERAL FINISH NOTE</b> DE-BURR AND BREAK ALL SHARP EDGES BEFORE FINISH AND/OR SHIPPING	UNLESS OTHERWISE SPECIFIED: DIMENSIONS ARE IN MILLIMETERS TOLERANCES: ANGULAR: MACH ± BEND ± TWO PLACE DECIMAL ±0.25 THREE PLACE DECIMAL ±0.125 FOUR PLACE DECIMAL ±0.0125 ANGLES ±.25° UNMARKED FILLETS/ROUNDS R1.588 DE-BURR ALL PARTS	NAME MAM DATE 9/20/2018	 LaserLinc, Inc. Phone: 888-707-4892 Info@laserlinc.com www.laserlinc.com		
	PROPRIETARY AND CONFIDENTIAL THE INFORMATION CONTAINED IN THIS DRAWING IS THE SOLE PROPERTY OF LASERLINC, INC. ANY REPRODUCTION IN PART OR AS A WHOLE WITHOUT THE WRITTEN PERMISSION OF LASERLINC, INC. IS PROHIBITED.	INTERPRET GEOMETRIC TOLERANCING PER: MATERIAL FINISH DO NOT SCALE DRAWING		TITLE: 0330-0002-00 Triton330 Triple-Axis NetLinc Micrometer Overall Mount Dimensions	
		63 RA SURFACE FINISH ALL FEATURES MUST MEET SPECIFICATION AFTER PLATING BEFORE POWDER-COAT IF PLATED OR POWDER-COATED SEE FINISH MACHINE ALL SURFACES	SIZE <b>B</b>	DWG. NO. 0330-0002-00	REV <b>A</b>
		SCALE: 2:5	SHEET 5 OF 6		

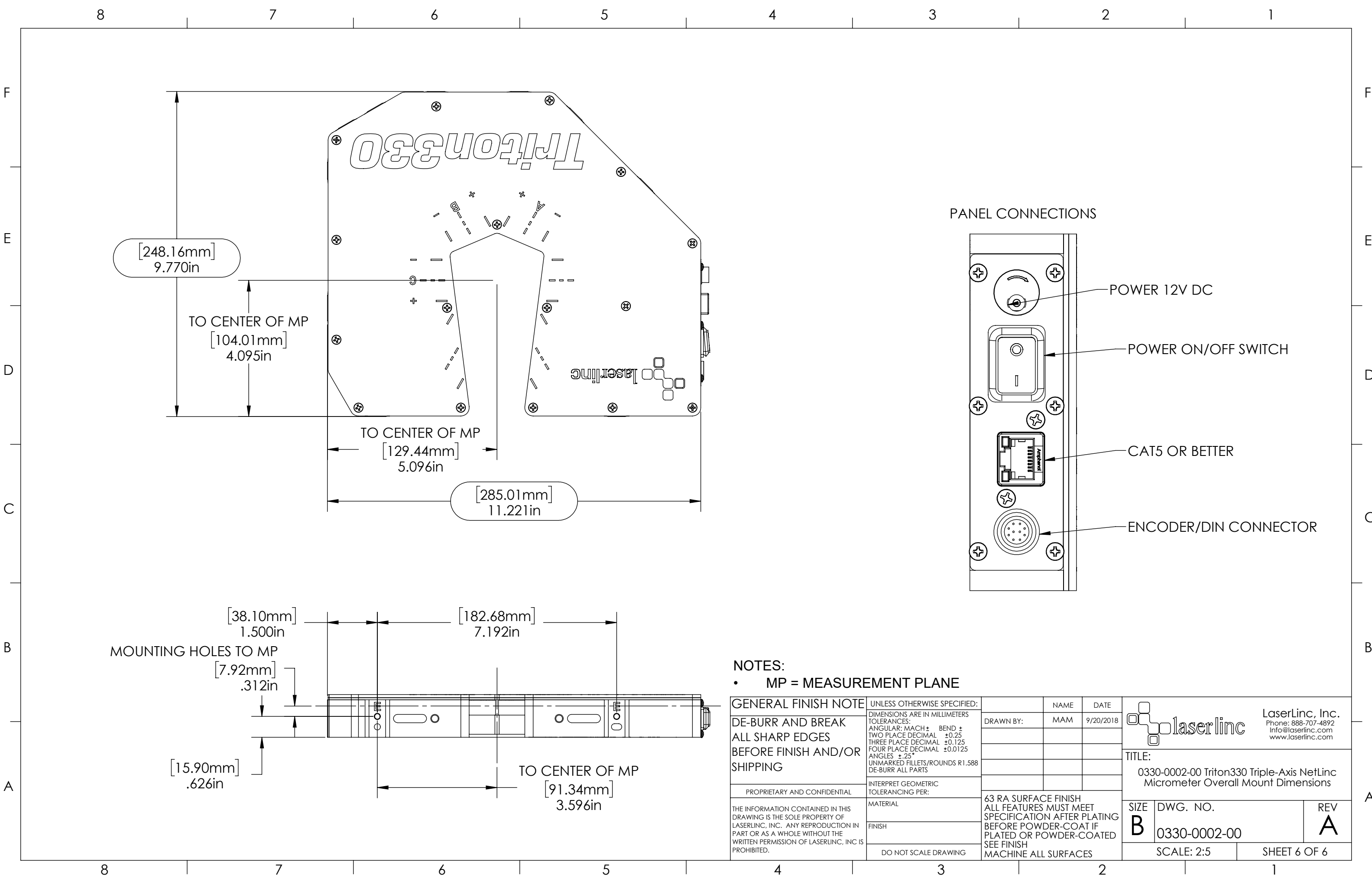

Triton330

Lasertec

PANEL CONNECTIONS

- POWER 12V DC
- POWER ON/OFF SWITCH
- CAT5 OR BETTER
- ENCODER/DIN CONNECTOR

NOTES:

- MP = MEASUREMENT PLANE

<b>GENERAL FINISH NOTE</b>		UNLESS OTHERWISE SPECIFIED:		NAME	DATE
DE-BURR AND BREAK ALL SHARP EDGES BEFORE FINISH AND/OR SHIPPING		DIMENSIONS ARE IN MILLIMETERS TOLERANCES: ANGULAR: MACH ± BEND ± TWO PLACE DECIMAL ±0.25 THREE PLACE DECIMAL ±0.125 FOUR PLACE DECIMAL ±0.0125 ANGLES ±.25° UNMARKED FILLETS/ROUNDS R1.588 DE-BURR ALL PARTS		DRAWN BY:	MAM 9/20/2018
PROPRIETARY AND CONFIDENTIAL		INTERPRET GEOMETRIC TOLERANCING PER:		 <b>Lasertec, Inc.</b> Phone: 888-707-4892 Info@lasertec.com www.lasertec.com	
THE INFORMATION CONTAINED IN THIS DRAWING IS THE SOLE PROPERTY OF LASERTEC, INC. ANY REPRODUCTION IN PART OR AS A WHOLE WITHOUT THE WRITTEN PERMISSION OF LASERTEC, INC. IS PROHIBITED.		MATERIAL			
		FINISH			
		DO NOT SCALE DRAWING		TITLE: 0330-0002-00 Triton330 Triple-Axis NetLinc Micrometer Overall Mount Dimensions	
		63 RA SURFACE FINISH ALL FEATURES MUST MEET SPECIFICATION AFTER PLATING BEFORE POWDER-COAT IF PLATED OR POWDER-COATED SEE FINISH MACHINE ALL SURFACES		SIZE	DWG. NO.
				<b>B</b>	0330-0002-00
				SCALE: 2:5	REV
					<b>A</b>
				SHEET 6 OF 6	