

8 7 6 5 4 3 2 1

F  
E  
D  
C  
B  
A

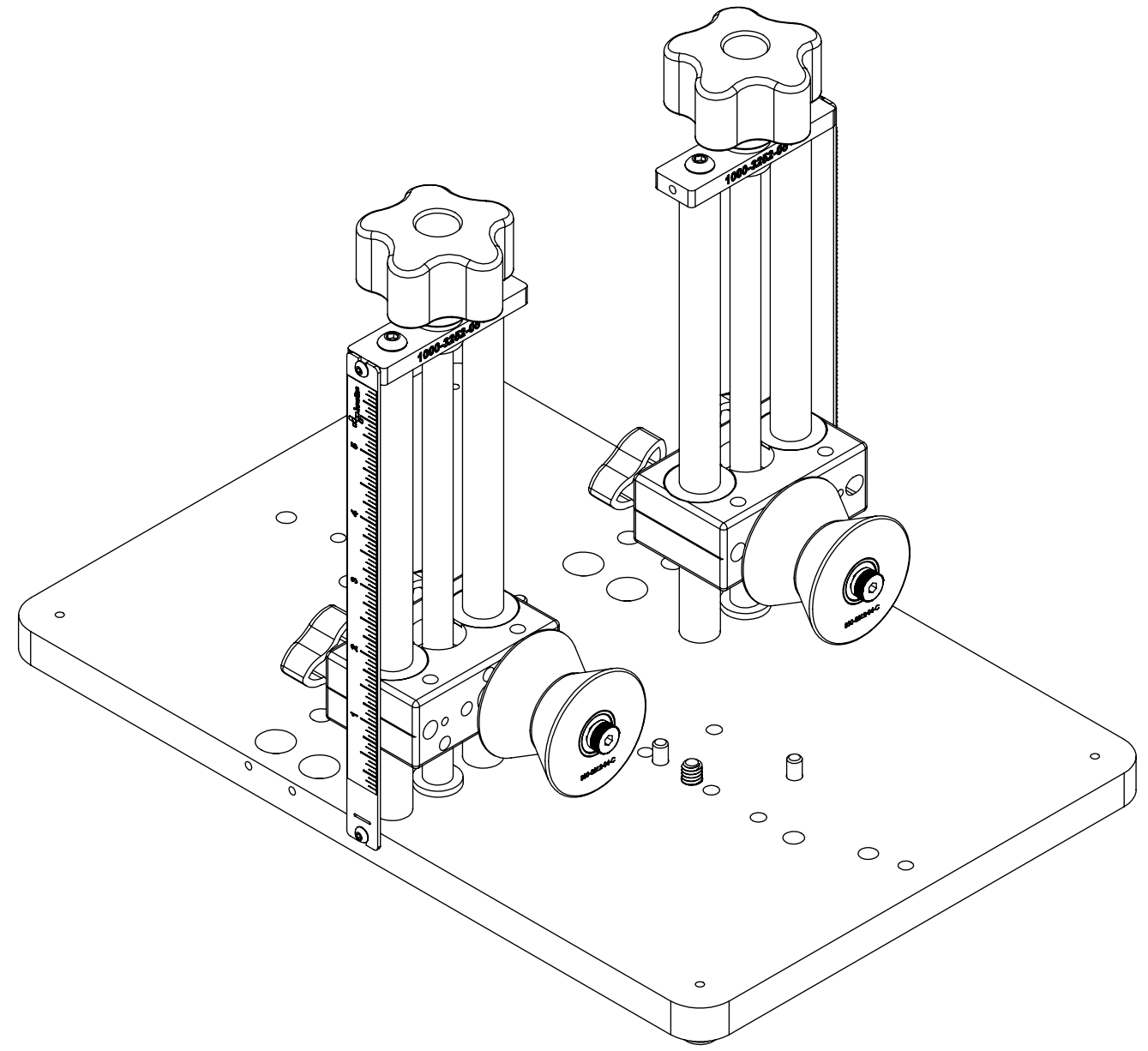

| REVISIONS |      |             |           |          |
|-----------|------|-------------|-----------|----------|
| ZONE      | REV. | DESCRIPTION | DATE      | APPROVED |
|           | A    | CHECK-IN    | 10/5/2018 | MAM      |

# 1000-0001-62 X30 PLATE MOUNT ROLLER GUIDE, 7IN

## INDEX

- (1) COVER PAGE
- (2) FIXTURE DIMENSIONS

|                                                                                                                          |                                                                                                                                                                                                                                    |                                                                                               |                                                                                                                                                                         |                           |
|--------------------------------------------------------------------------------------------------------------------------|------------------------------------------------------------------------------------------------------------------------------------------------------------------------------------------------------------------------------------|-----------------------------------------------------------------------------------------------|-------------------------------------------------------------------------------------------------------------------------------------------------------------------------|---------------------------|
| <b>GENERAL FINISH NOTE</b><br><b>DE-BURR AND BREAK</b><br><b>ALL SHARP EDGES</b><br><b>BEFORE FINISH AND/OR SHIPPING</b> | UNLESS OTHERWISE SPECIFIED:<br>DIMENSIONS ARE IN INCHES<br>TOLERANCES:<br>ANGLES ±.25<br>TWO PLACE DECIMAL ±0.010<br>THREE PLACE DECIMAL ±0.005<br>FOUR PLACE DECIMAL ±0.0005<br>UNMARKED FILLETS/CHAMFER .06<br>DE-BURR ALL PARTS | NAME<br>DATE                                                                                  |  LASERLINC, INC.<br>PHONE: 888-707-4892<br>INFO@LASERLINC.COM<br>WWW.LASERLINC.COM |                           |
|                                                                                                                          | <b>PROPRIETARY AND CONFIDENTIAL</b><br>THE INFORMATION CONTAINED IN THIS DRAWING IS THE SOLE PROPERTY OF LASERLINC, INC. ANY REPRODUCTION IN PART OR AS A WHOLE WITHOUT THE WRITTEN PERMISSION OF LASERLINC, INC. IS PROHIBITED.   | INTERPRET GEOMETRIC TOLERANCING PER: ASME Y14.5<br>MATERIAL<br>FINISH<br>DO NOT SCALE DRAWING |                                                                                                                                                                         | DRAWN BY: MWD<br>9/3/2021 |
|                                                                                                                          | 63 RA SURFACE FINISH<br>ALL FEATURES MUST MEET SPECIFICATION AFTER PLATING BEFORE POWDER-COAT IF PLATED OR POWDER-COATED<br><b>SEE FINISH</b>                                                                                      | SIZE<br><b>B</b>                                                                              | DWG. NO.<br>1000-0000-62                                                                                                                                                | REV<br><b>A</b>           |
|                                                                                                                          |                                                                                                                                                                                                                                    | SCALE: 1:2                                                                                    | SHEET 1 OF 5                                                                                                                                                            |                           |

8 7 6 5 4 3 2 1

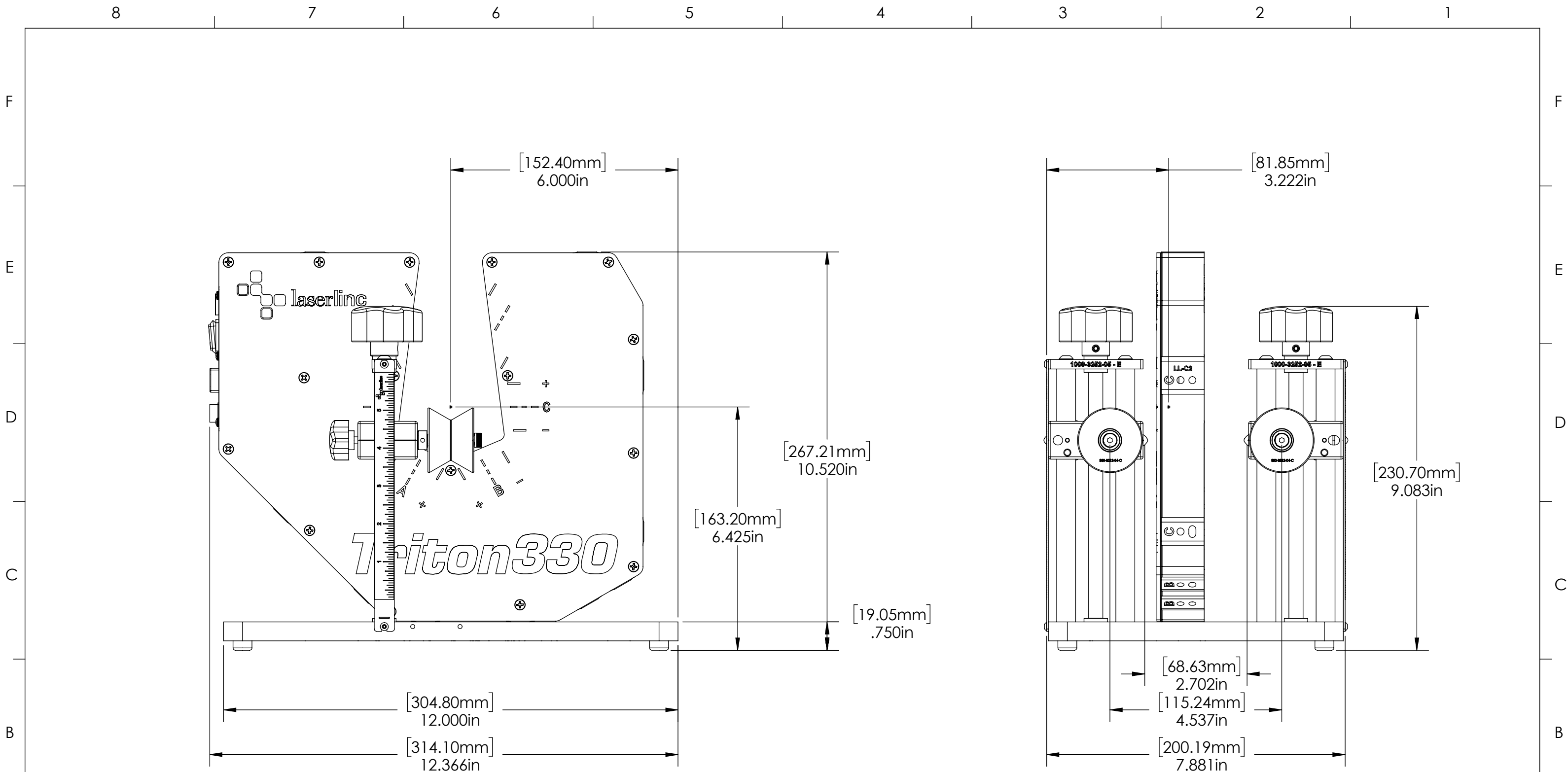

|                                                                                                                                                                                                          |  |                                                                                                                                                                                                     |  |                                                                                                                                                        |                          |
|----------------------------------------------------------------------------------------------------------------------------------------------------------------------------------------------------------|--|-----------------------------------------------------------------------------------------------------------------------------------------------------------------------------------------------------|--|--------------------------------------------------------------------------------------------------------------------------------------------------------|--------------------------|
| <b>GENERAL FINISH NOTE</b>                                                                                                                                                                               |  | UNLESS OTHERWISE SPECIFIED:                                                                                                                                                                         |  | NAME                                                                                                                                                   | DATE                     |
| <b>DE-BURR AND BREAK<br/>ALL SHARP EDGES<br/>BEFORE FINISH AND/OR<br/>SHIPPING</b>                                                                                                                       |  | DIMENSIONS ARE IN INCHES<br>TOLERANCES:<br>ANGLES ±.25<br>TWO PLACE DECIMAL ±0.010<br>THREE PLACE DECIMAL ±0.005<br>FOUR PLACE DECIMAL ±0.0005<br>UNMARKED FILLETS/CHAMFER .06<br>DE-BURR ALL PARTS |  | DRAWN BY:                                                                                                                                              | MWD 9/3/2021             |
| <b>PROPRIETARY AND CONFIDENTIAL</b>                                                                                                                                                                      |  | INTERPRET GEOMETRIC<br>TOLERANCING PER: ASME Y14.5                                                                                                                                                  |  |                                                                                                                                                        |                          |
| THE INFORMATION CONTAINED IN THIS<br>DRAWING IS THE SOLE PROPERTY OF<br>LASERLINC, INC. ANY REPRODUCTION IN<br>PART OR AS A WHOLE WITHOUT THE<br>WRITTEN PERMISSION OF LASERLINC, INC. IS<br>PROHIBITED. |  | MATERIAL                                                                                                                                                                                            |  | 63 RA SURFACE FINISH<br>ALL FEATURES MUST MEET<br>SPECIFICATION AFTER PLATING<br>BEFORE POWDER-COAT IF<br>PLATED OR POWDER-COATED<br><b>SEE FINISH</b> |                          |
|                                                                                                                                                                                                          |  | FINISH                                                                                                                                                                                              |  | TITLE:<br>1000-0001-62 X30 PLATE MOUNT ROLLER<br>GUIDE, 7IN MICROMETER OVERALL<br>DIMENSIONS                                                           |                          |
|                                                                                                                                                                                                          |  | DO NOT SCALE DRAWING                                                                                                                                                                                |  | SIZE<br><b>B</b>                                                                                                                                       | DWG. NO.<br>1000-0001-62 |
|                                                                                                                                                                                                          |  |                                                                                                                                                                                                     |  | REV<br><b>A</b>                                                                                                                                        |                          |
|                                                                                                                                                                                                          |  |                                                                                                                                                                                                     |  | SCALE: 2:5                                                                                                                                             | SHEET 5 OF 5             |

**LASERLINC, INC.**  
 PHONE: 888-707-4892  
 INFO@LASERLINC.COM  
 WWW.LASERLINC.COM