

8 7 6 5 4 3 2 1

REVISIONS				
ZONE	REV.	DESCRIPTION	DATE	APPROVED
	A	Check-In	1/8/2013	MAM

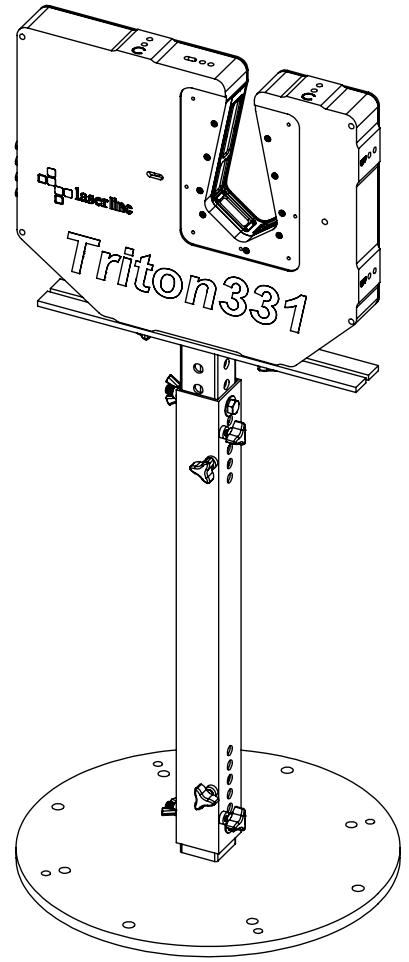

Stand for Triton331

Overall Dimensions

INDEX

- (1) Cover Page
- (2) Fixture Dimensions
- (3) Mounted Dimensions

UNLESS OTHERWISE SPECIFIED:		NAME	DATE	 LaserLinc, Inc. Phone: 888-707-4892 Info@laserline.com www.laserline.com
DIMENSIONS ARE IN INCHES TOLERANCES: ANGULAR: MACH ± BEND ± TWO PLACE DECIMAL ±0.010 THREE PLACE DECIMAL ±0.005 FOUR PLACE DECIMAL ±0.0005 ANGLES ±.25° UNMARKED FILLETS/ROUNDS R.0625 DE-BURR ALL PARTS		DRAWN BY:	MAM	
INTERPRET GEOMETRIC TOLERANCING PER:		63 RA SURFACE FINISH ALL FEATURES MUST MEET SPECIFICATION AFTER PLATING BEFORE POWDER-COAT IF PLATED OR POWDER-COATED SEE FINISH MACHINE ALL SURFACES		
PROPRIETARY AND CONFIDENTIAL THE INFORMATION CONTAINED IN THIS DRAWING IS THE SOLE PROPERTY OF LASERLINC, INC. ANY REPRODUCTION IN PART OR AS A WHOLE WITHOUT THE WRITTEN PERMISSION OF LASERLINC, INC IS PROHIBITED.		MATERIAL	TITLE: 00331-28 Stand for Triton331 Overall Dimensions	
DO NOT SCALE DRAWING		FINISH	SIZE B	DWG. NO. 00331-28
			SCALE: 1:8	REV A
			SHEET 1 OF 3	

8 7 6 5 4 3 2 1

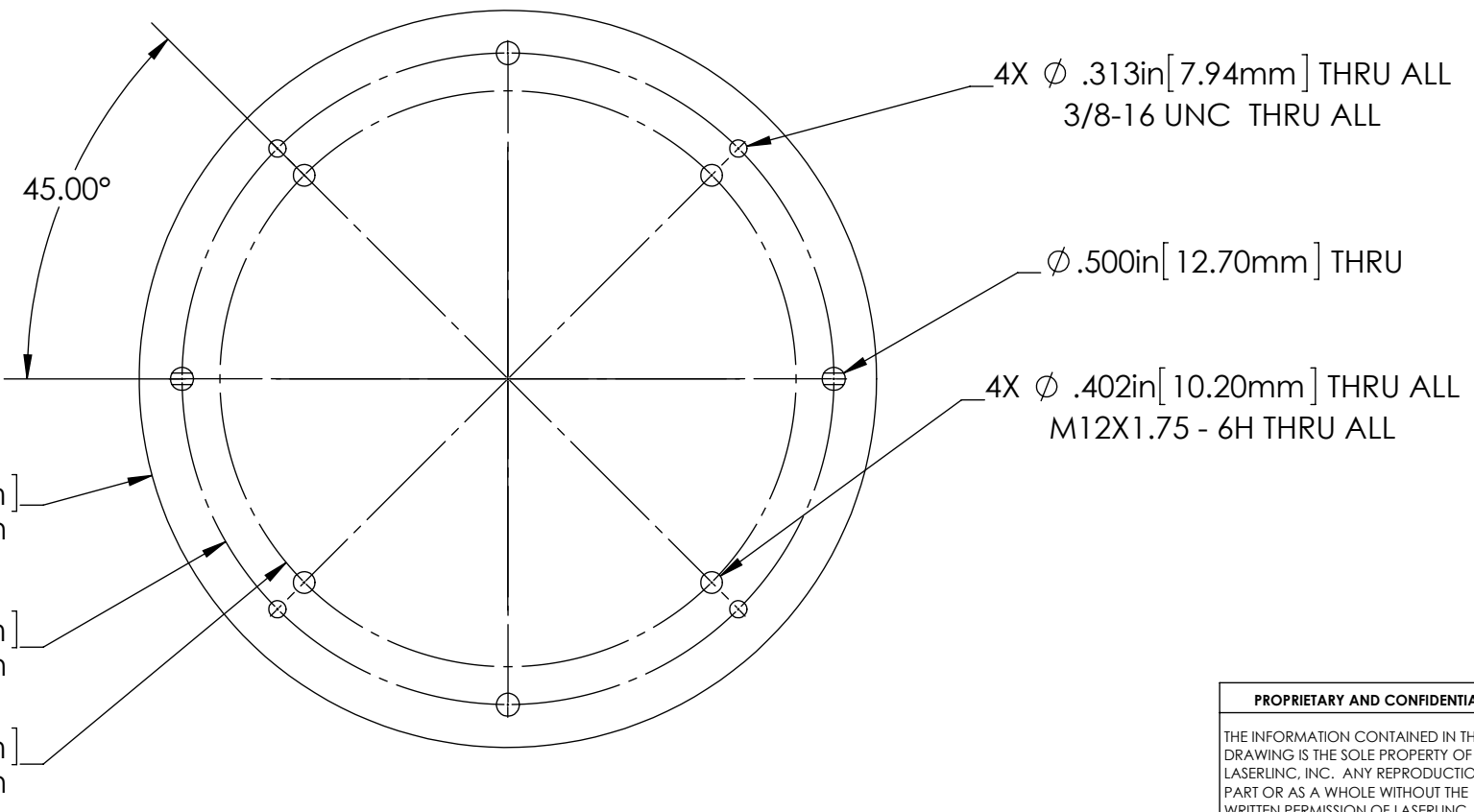
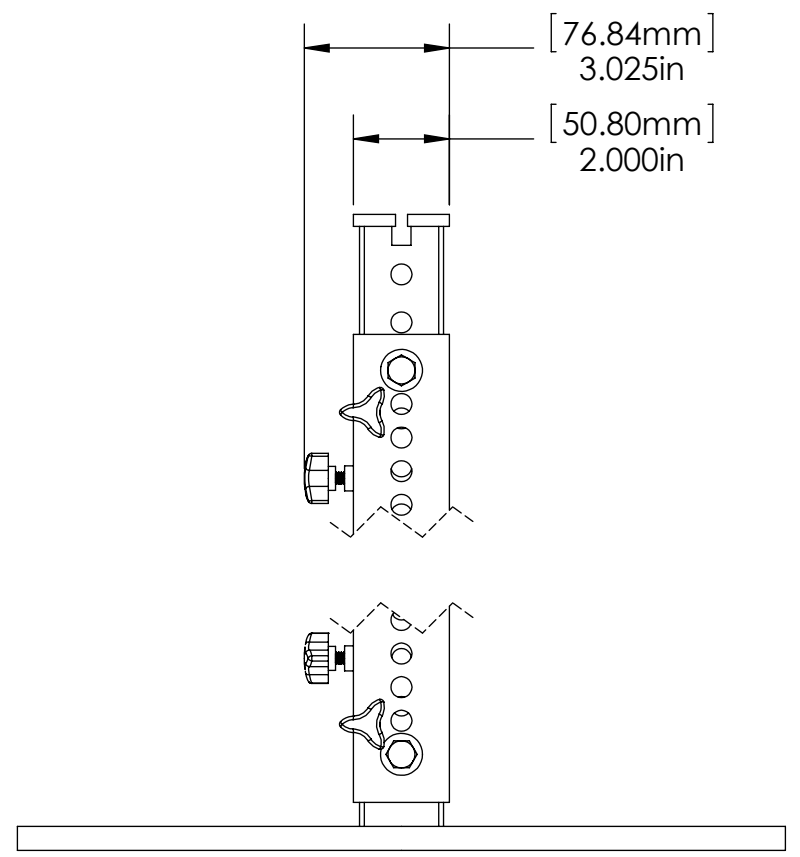
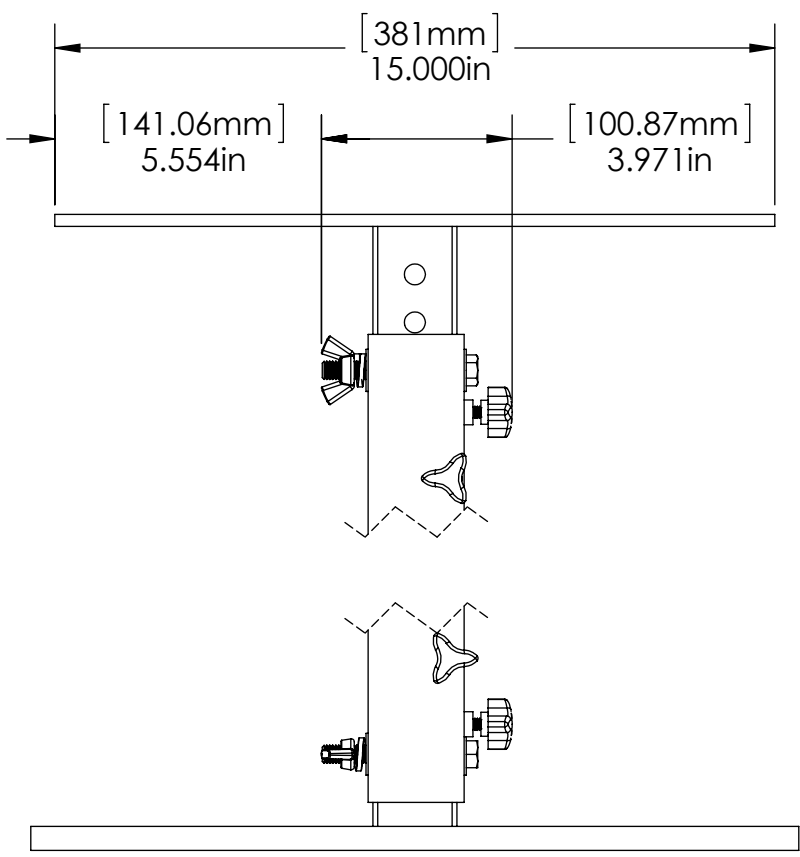
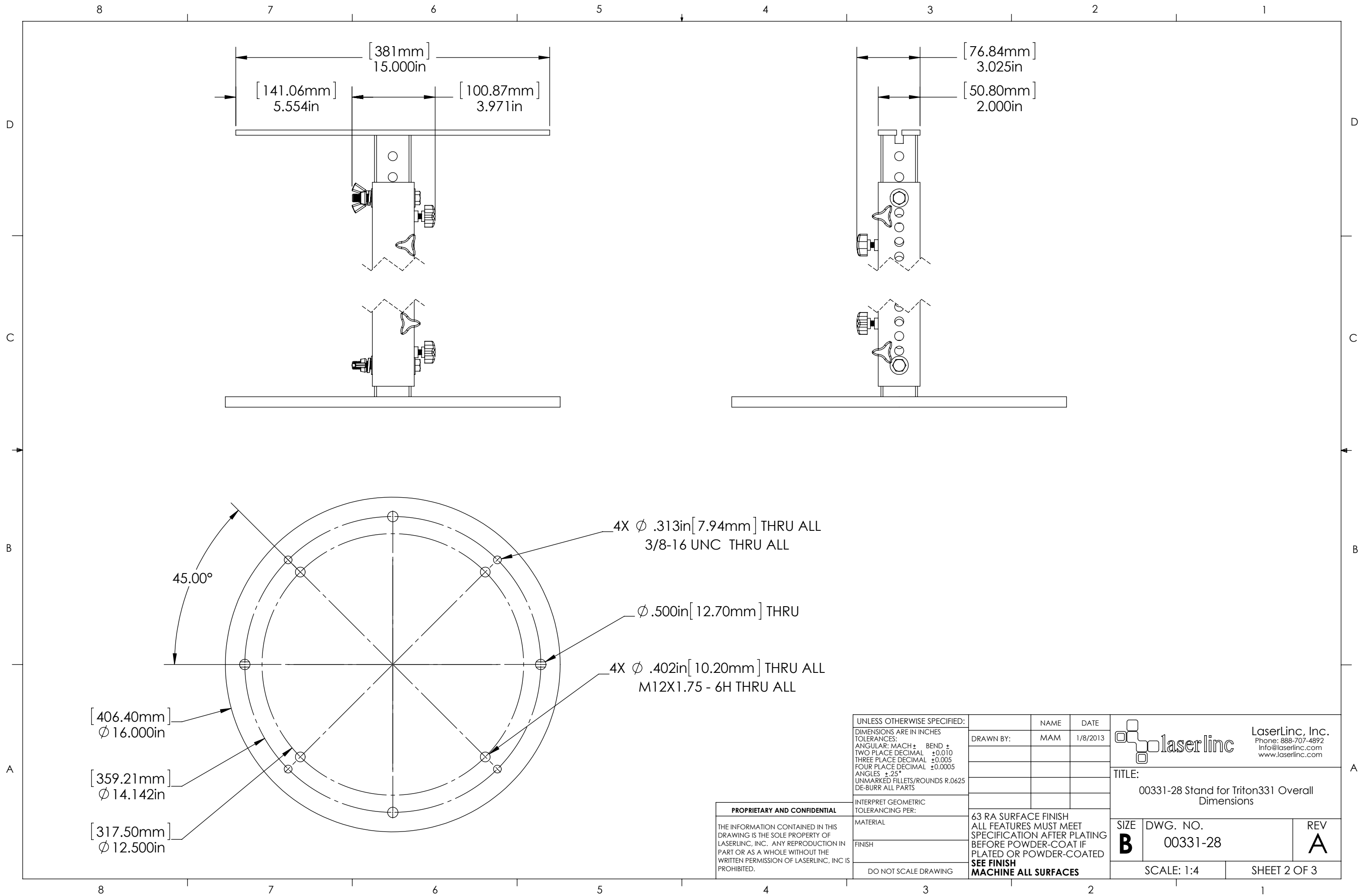

UNLESS OTHERWISE SPECIFIED:
DIMENSIONS ARE IN INCHES
TOLERANCES:
ANGULAR: MACH \pm BEND \pm
TWO PLACE DECIMAL \pm 0.010
THREE PLACE DECIMAL \pm 0.005
FOUR PLACE DECIMAL \pm 0.0005
ANGLES \pm .25°
UNMARKED FILLETS/ROUNDS R.0625
DE-BURR ALL PARTS

NAME	DATE
MAM	1/8/2013
DRAWN BY:	

laserlinc LaserLinc, Inc.
Phone: 888-707-4892
Info@laserlinc.com
www.laserlinc.com

TITLE:
00331-28 Stand for Triton331 Overall Dimensions

PROPRIETARY AND CONFIDENTIAL

THE INFORMATION CONTAINED IN THIS DRAWING IS THE SOLE PROPERTY OF LASERLINC, INC. ANY REPRODUCTION IN PART OR AS A WHOLE WITHOUT THE WRITTEN PERMISSION OF LASERLINC, INC IS PROHIBITED.

INTERPRET GEOMETRIC TOLERANCING PER:	63 RA SURFACE FINISH ALL FEATURES MUST MEET SPECIFICATION AFTER PLATING BEFORE POWDER-COAT IF PLATED OR POWDER-COATED SEE FINISH MACHINE ALL SURFACES
MATERIAL	
FINISH	
DO NOT SCALE DRAWING	

SIZE B	DWG. NO. 00331-28	REV A
SCALE: 1:4		SHEET 2 OF 3

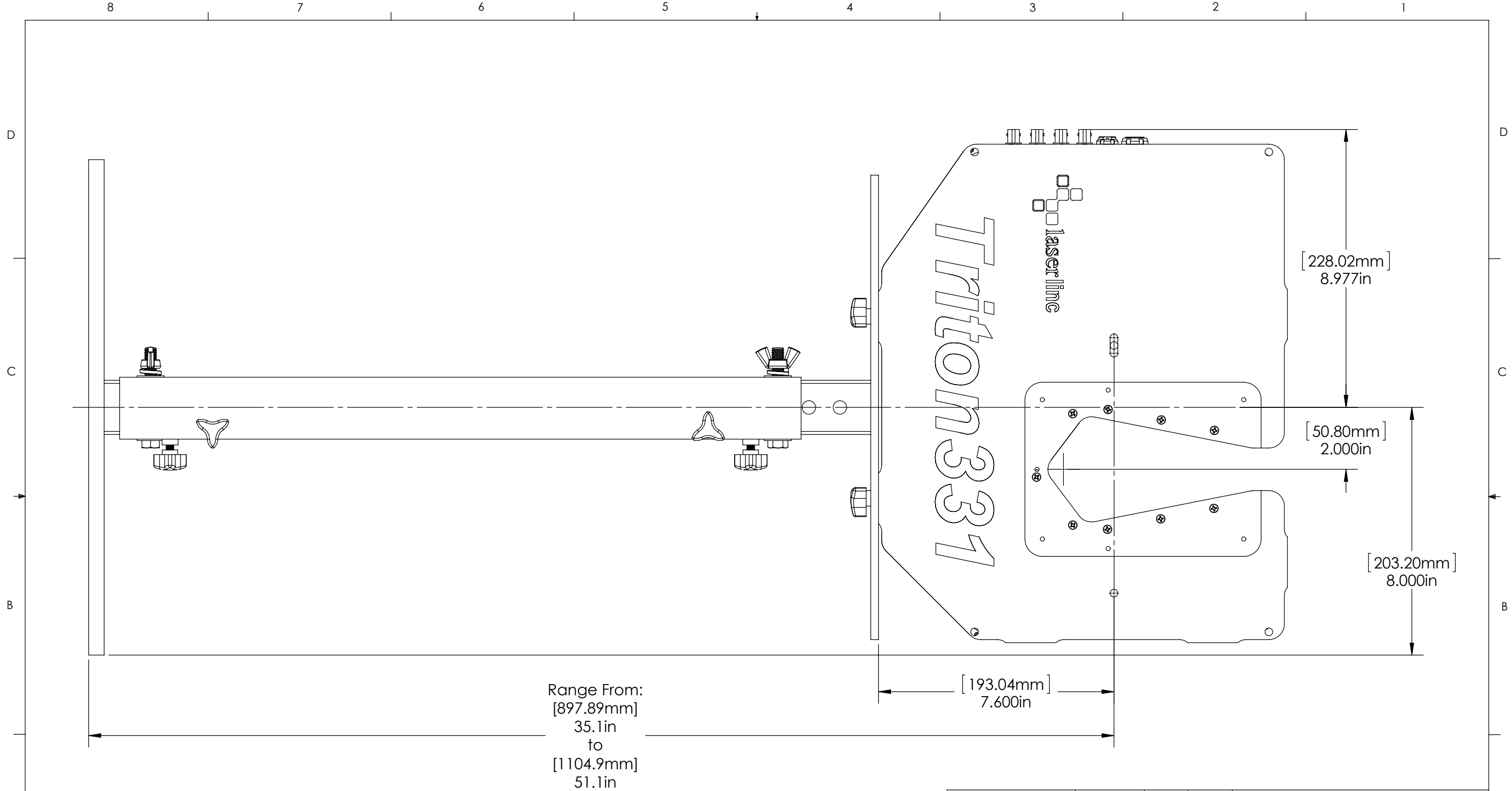

UNLESS OTHERWISE SPECIFIED:		NAME	DATE
DIMENSIONS ARE IN INCHES		DRAWN BY:	MAM 1/8/2013
TOLERANCES:			
ANGULAR: MACH ± BEND ±			
TWO PLACE DECIMAL ±0.010			
THREE PLACE DECIMAL ±0.005			
FOUR PLACE DECIMAL ±0.0005			
ANGLES ±.25°			
UNMARKED FILLETS/ROUNDS R.0625			
DE-BURR ALL PARTS			
INTERPRET GEOMETRIC TOLERANCING PER:		63 RA SURFACE FINISH	
MATERIAL		ALL FEATURES MUST MEET SPECIFICATION AFTER PLATING BEFORE POWDER-COAT IF PLATED OR POWDER-COATED	
FINISH		SEE FINISH	
DO NOT SCALE DRAWING		MACHINE ALL SURFACES	
LaserLinc, Inc. Phone: 888-707-4892 Info@laserlinc.com www.laserlinc.com		TITLE: 00331-28 Stand for Triton331 Overall Dimensions	
SIZE B	DWG. NO. 00331-28	REV A	
SCALE: 1:3		SHEET 3 OF 3	

PROPRIETARY AND CONFIDENTIAL

THE INFORMATION CONTAINED IN THIS DRAWING IS THE SOLE PROPERTY OF LASERLINC, INC. ANY REPRODUCTION IN PART OR AS A WHOLE WITHOUT THE WRITTEN PERMISSION OF LASERLINC, INC IS PROHIBITED.