

8

7

6

5

4

3

2

1

REVISIONS				
ZONE	REV.	DESCRIPTION	DATE	APPROVED
	A	Check-In	9/27/2012	MAM

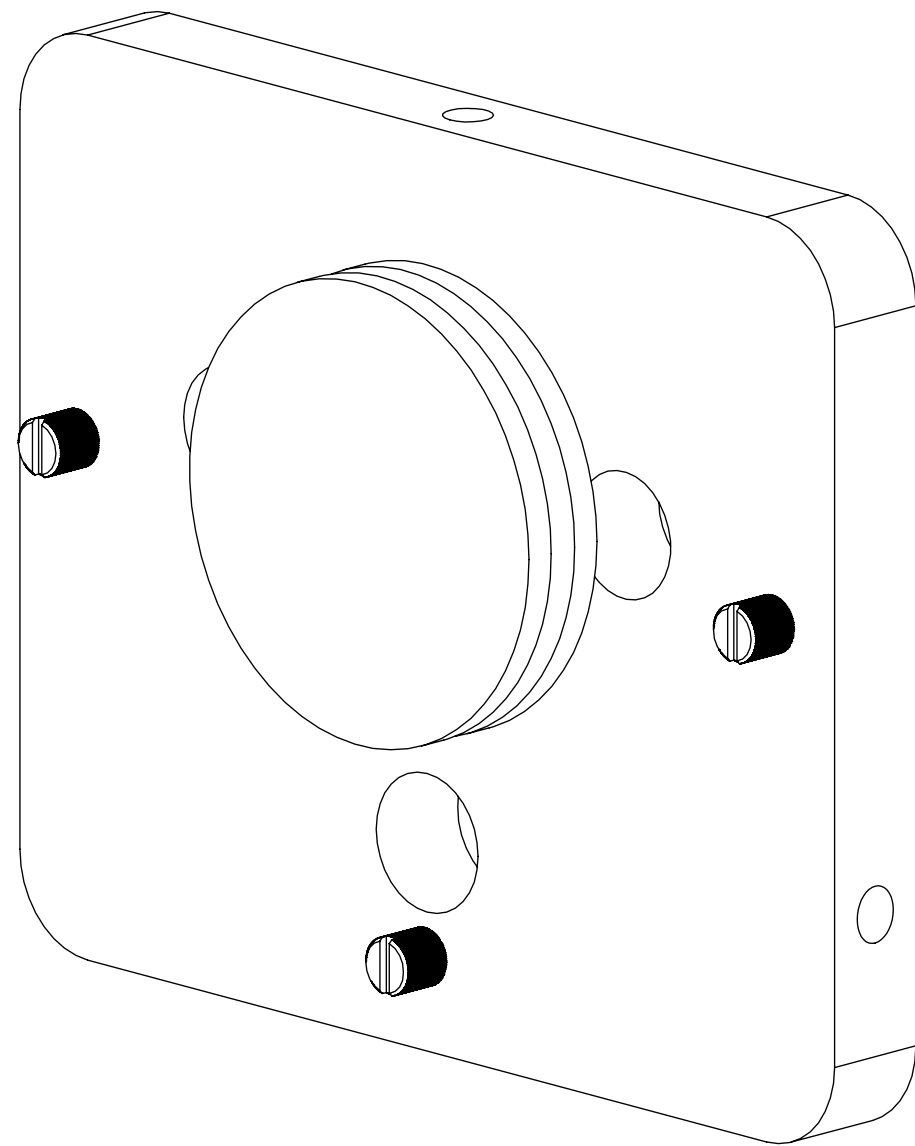

CALIBRATION FIXTURE FOR TRITON331 OVERALL DIMENSIONS

INDEX

- (1) COVER PAGE
- (2) FIXTURE DIMENSION
- (3) MOUNTED DIMENSION

GENERAL FINISH NOTE DE-BURR AND BREAK ALL SHARP EDGES BEFORE FINISH AND/OR SHIPPING	UNLESS OTHERWISE SPECIFIED:	NAME	DATE	 LaserLinc, Inc. Phone: 888-707-4892 Info@laserlinc.com www.laserlinc.com
	DIMENSIONS ARE IN INCHES TOLERANCES: ANGLES ±.25° TWO PLACE DECIMAL ±0.010 THREE PLACE DECIMAL ±0.005 FOUR PLACE DECIMAL ±0.0005 UNMARKED FILLETS/CHAMFER .06 DE-BURR ALL PARTS	DRAWN BY:	MAM	
PROPRIETARY AND CONFIDENTIAL	INTERPRET GEOMETRIC TOLERANCING PER: ASME Y14.5			TITLE: 0331-0000-34 Calibration Fixture for Triton331 Micrometer Overall Dimensions
THE INFORMATION CONTAINED IN THIS DRAWING IS THE SOLE PROPERTY OF LASERLINC, INC. ANY REPRODUCTION IN PART OR AS A WHOLE WITHOUT THE WRITTEN PERMISSION OF LASERLINC, INC. IS PROHIBITED.	MATERIAL	63 RA SURFACE FINISH ALL FEATURES MUST MEET SPECIFICATION AFTER PLATING BEFORE POWDER-COAT IF PLATED OR POWDER-COATED SEE FINISH		SIZE B
	FINISH			DWG. NO. 00331-34
	DO NOT SCALE DRAWING			REV A
			SCALE: 1:1	SHEET 1 OF 3

8

7

6

5

4

3

2

1

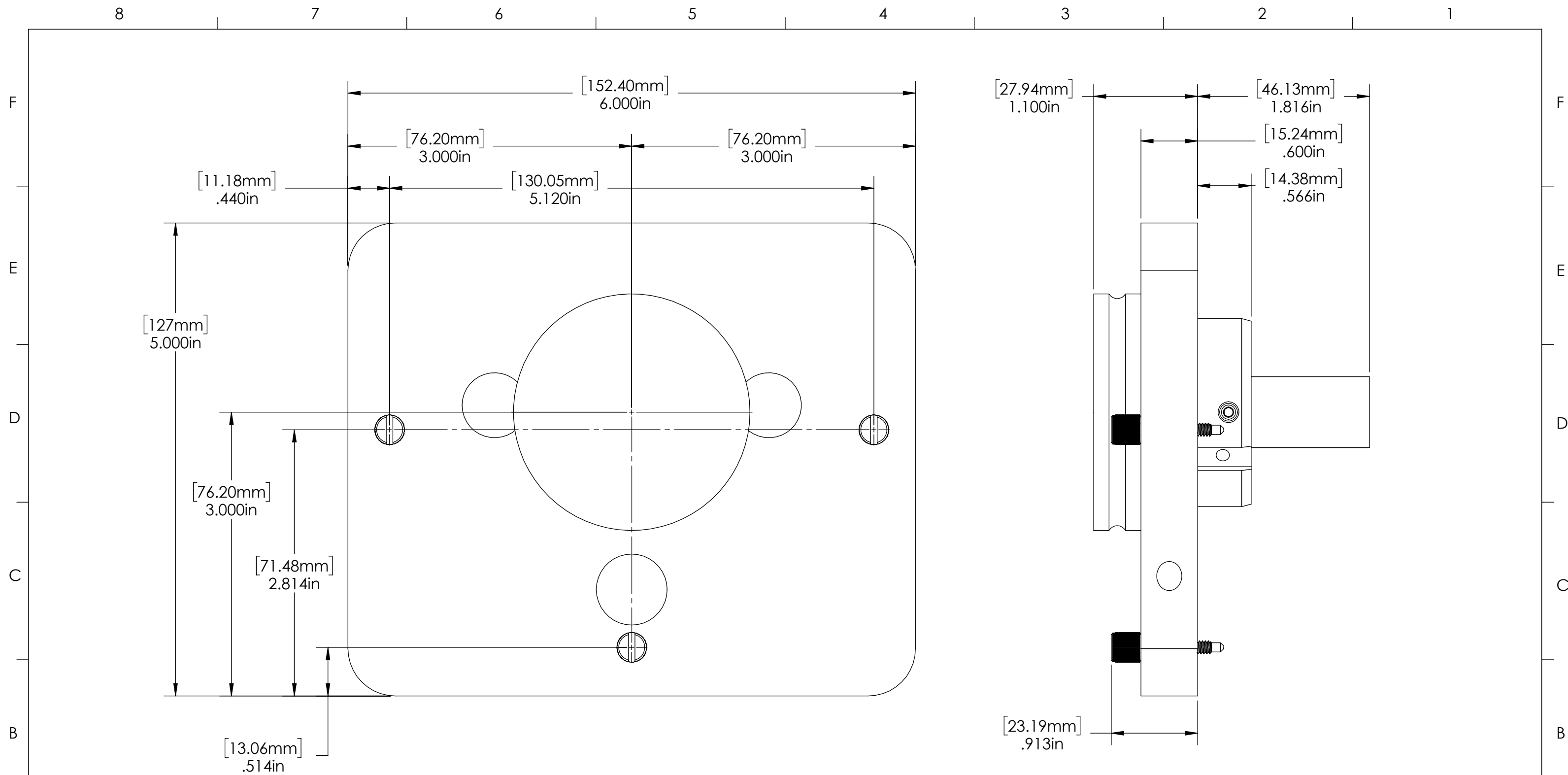

GENERAL FINISH NOTE	UNLESS OTHERWISE SPECIFIED:	NAME	DATE	 LaserLinc, Inc. Phone: 888-707-4892 Info@laserlinc.com www.laserlinc.com	
	DE-BURR AND BREAK ALL SHARP EDGES BEFORE FINISH AND/OR SHIPPING	DIMENSIONS ARE IN INCHES TOLERANCES: ANGLES ±.25° TWO PLACE DECIMAL ±0.010 THREE PLACE DECIMAL ±0.005 FOUR PLACE DECIMAL ±0.0005 UNMARKED FILLETS/CHAMFER .06 DE-BURR ALL PARTS	DRAWN BY:		MAM
PROPRIETARY AND CONFIDENTIAL	INTERPRET GEOMETRIC TOLERANCING PER: ASME Y14.5	63 RA SURFACE FINISH ALL FEATURES MUST MEET SPECIFICATION AFTER PLATING BEFORE POWDER-COAT IF PLATED OR POWDER-COATED SEE FINISH			TITLE: 0331-0000-34 Calibration Fixture for Triton331 Micrometer Overall Dimensions
THE INFORMATION CONTAINED IN THIS DRAWING IS THE SOLE PROPERTY OF LASERLINC, INC. ANY REPRODUCTION IN PART OR AS A WHOLE WITHOUT THE WRITTEN PERMISSION OF LASERLINC, INC. IS PROHIBITED.	MATERIAL FINISH DO NOT SCALE DRAWING	SIZE B	DWG. NO. 00331-34	REV A	SCALE: 1:1 SHEET 2 OF 3

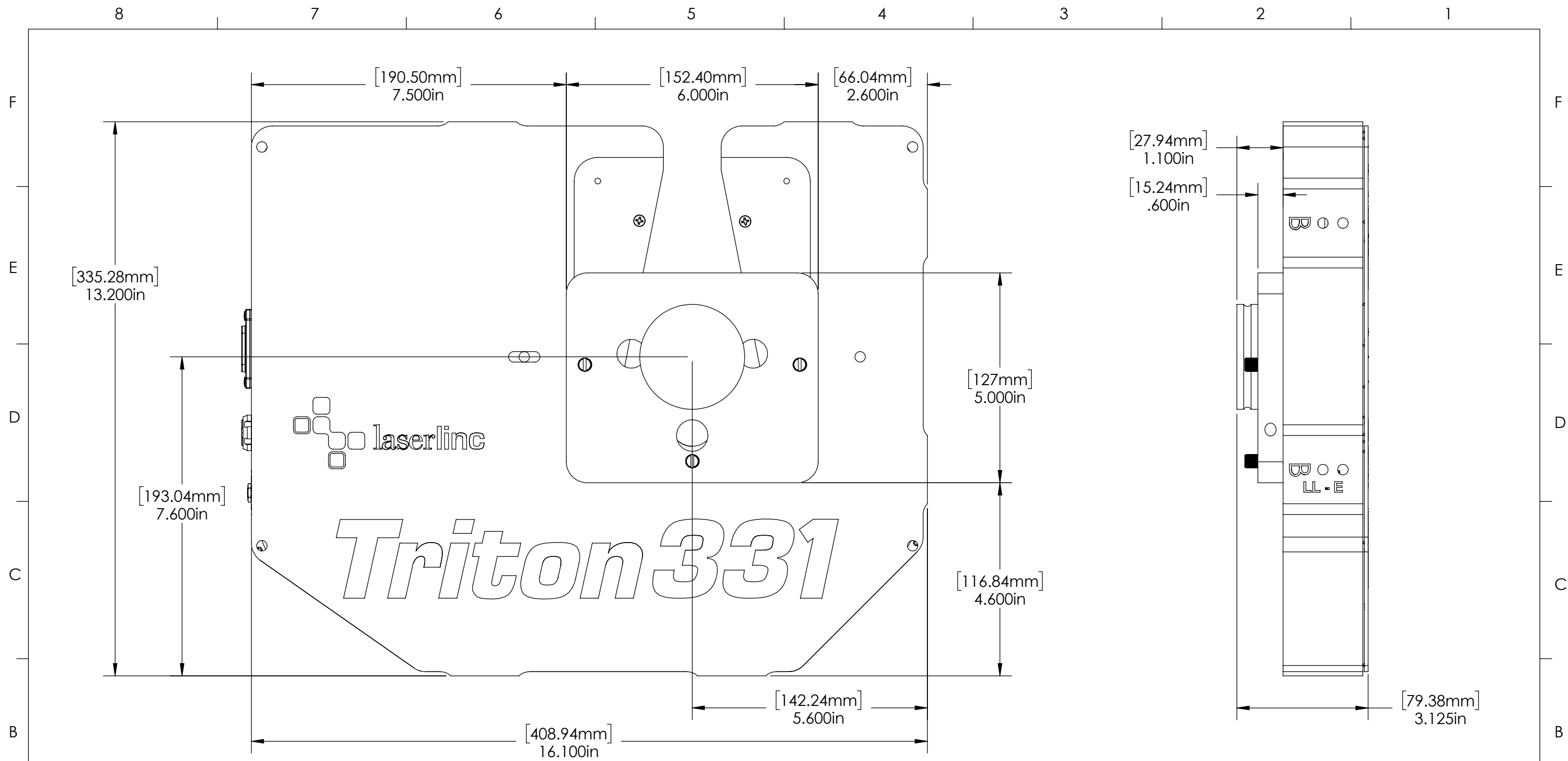

GENERAL FINISH NOTE DE-BURR AND BREAK ALL SHARP EDGES BEFORE FINISH AND/OR SHIPPING PROPRIETARY AND CONFIDENTIAL THE INFORMATION CONTAINED IN THIS DRAWING IS THE SOLE PROPERTY OF LASERLINC, INC. ANY REPRODUCTION IN PART OR AS A WHOLE WITHOUT THE WRITTEN PERMISSION OF LASERLINC, INC IS PROHIBITED.	UNLESS OTHERWISE SPECIFIED: DIMENSIONS ARE IN INCHES TOLERANCES: ANGLES ±.25 TWO PLACE DECIMAL ±0.010 THREE PLACE DECIMAL ±0.005 FOUR PLACE DECIMAL ±0.0005 UNMARKED FILLETS/CHAMFER .06 DE-BURR ALL PARTS	NAME DATE DRAWN BY: MAM 9/27/2012	 LaserLinc, Inc. Phone: 888-707-4892 Info@laserlinc.com www.laserlinc.com
	INTERPRET GEOMETRIC TOLERANCING PER: ASME Y14.5 MATERIAL FINISH DO NOT SCALE DRAWING	TITLE: 0331-0000-34 Calibration Fixture for Triton331 Micrometer Overall Dimensions SIZE B DWG. NO. 00331-34 REV A SCALE: 1:2.25 SHEET 3 OF 3	

