

8

7

6

5

4

3

2

1

ZONE		REV.	DESCRIPTION	DATE	APPROVED
		A	Check-in	5/19/2011	ZRP
		B	Changed Overall Size	6/7/2011	ZRP

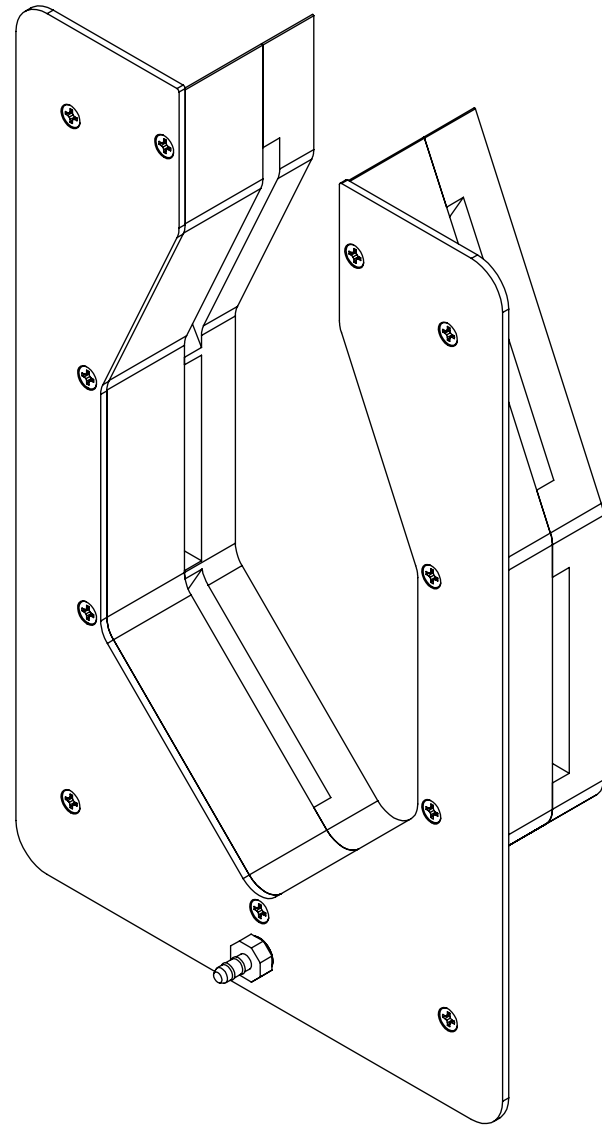

TRITON360 AIR PURGE FIXTURE OVERALLS

INDEX

- (1) COVER PAGE
- (2) FIXTURE DIMENSIONS
- (3) MOUNTED DIMENSIONS

GENERAL FINISH NOTE		UNLESS OTHERWISE SPECIFIED:		NAME	DATE
DE-BURR AND BREAK ALL SHARP EDGES BEFORE FINISH AND/OR SHIPPING		DIMENSIONS ARE IN INCHES TOLERANCES: ANGLES ±.25° TWO PLACE DECIMAL ±0.010 THREE PLACE DECIMAL ±0.005 FOUR PLACE DECIMAL ±0.0005 UNMARKED FILLETS/CHAMFER .06 DE-BURR ALL PARTS		DRAWN BY:	EMM 11/20/2020
PROPRIETARY AND CONFIDENTIAL		INTERPRET GEOMETRIC TOLERANCING PER: ASME Y14.5			
THE INFORMATION CONTAINED IN THIS DRAWING IS THE SOLE PROPERTY OF LASERLINC, INC. ANY REPRODUCTION IN PART OR AS A WHOLE WITHOUT THE WRITTEN PERMISSION OF LASERLINC, INC. IS PROHIBITED.		MATERIAL		63 RA SURFACE FINISH ALL FEATURES MUST MEET SPECIFICATION AFTER PLATING BEFORE POWDER-COAT IF PLATED OR POWDER-COATED SEE FINISH	
		FINISH			
DO NOT SCALE DRAWING				LaserLinc, Inc. Phone: 888-707-4892 Info@laserlinc.com www.laserlinc.com	
				TITLE: 0360-0000-30 TRITON360 AIR PURGE FIXTURE OVERALLS	
				SIZE B	DWG. NO. 0360-0000-30
				REV B	
				SCALE: 1:2	SHEET 1 OF 3

8

7

6

5

4

3

2

1

F

E

D

C

B

A

F

E

D

C

B

A

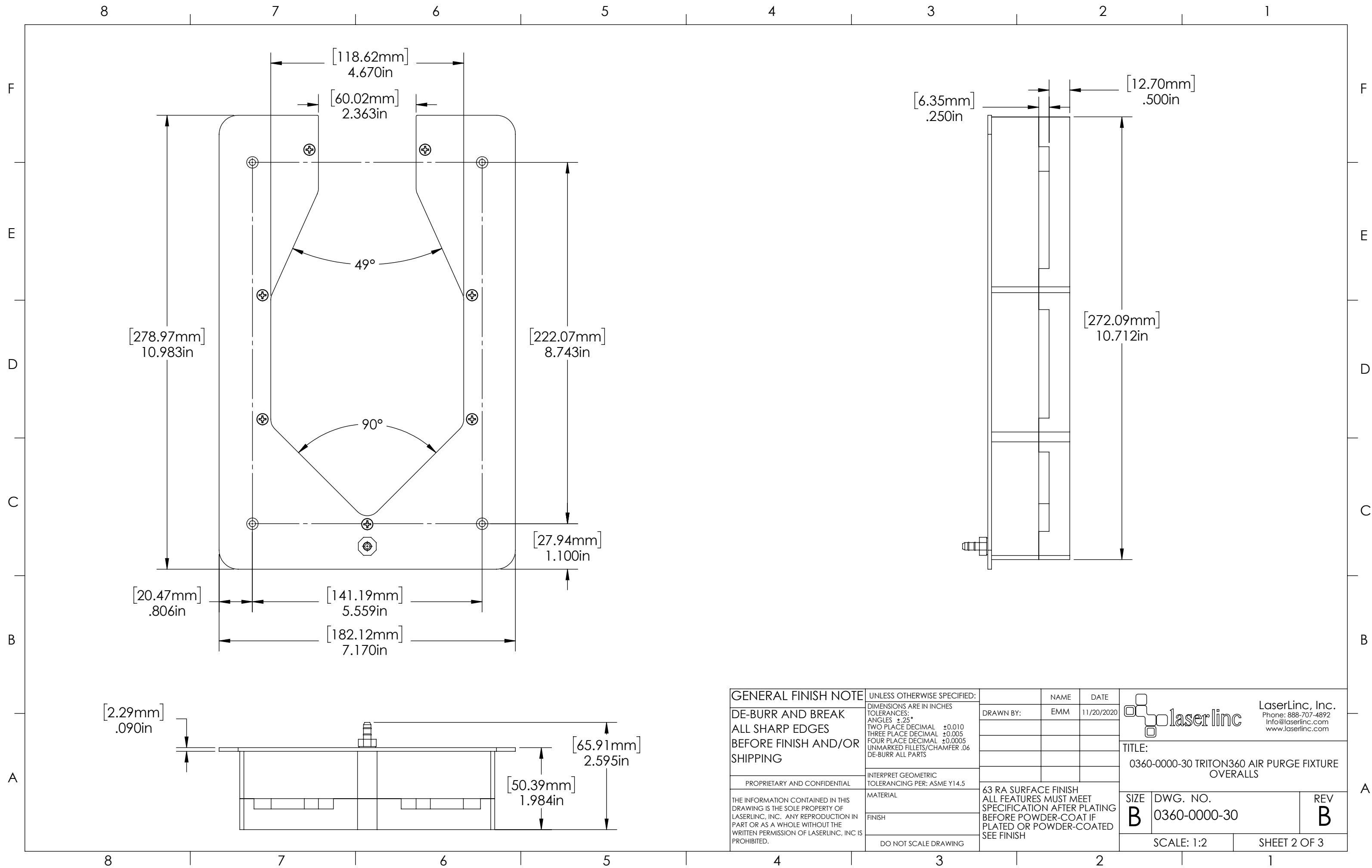

GENERAL FINISH NOTE DE-BURR AND BREAK ALL SHARP EDGES BEFORE FINISH AND/OR SHIPPING	UNLESS OTHERWISE SPECIFIED: DIMENSIONS ARE IN INCHES TOLERANCES: ANGLES ±.25° TWO PLACE DECIMAL ±0.010 THREE PLACE DECIMAL ±0.005 FOUR PLACE DECIMAL ±0.0005 UNMARKED FILLETS/CHAMFER .06 DE-BURR ALL PARTS	NAME	DATE	 LaserLinc, Inc. Phone: 888-707-4892 Info@laserlinc.com www.laserlinc.com
		DRAWN BY:	EMM	
PROPRIETARY AND CONFIDENTIAL	INTERPRET GEOMETRIC TOLERANCING PER: ASME Y14.5	TITLE: 0360-0000-30 TRITON360 AIR PURGE FIXTURE OVERALLS		
THE INFORMATION CONTAINED IN THIS DRAWING IS THE SOLE PROPERTY OF LASERLINC, INC. ANY REPRODUCTION IN PART OR AS A WHOLE WITHOUT THE WRITTEN PERMISSION OF LASERLINC, INC. IS PROHIBITED.	MATERIAL	63 RA SURFACE FINISH ALL FEATURES MUST MEET SPECIFICATION AFTER PLATING BEFORE POWDER-COAT IF PLATED OR POWDER-COATED SEE FINISH		
	FINISH			
DO NOT SCALE DRAWING		SIZE B	DWG. NO. 0360-0000-30	REV B
		SCALE: 1:2	SHEET 2 OF 3	

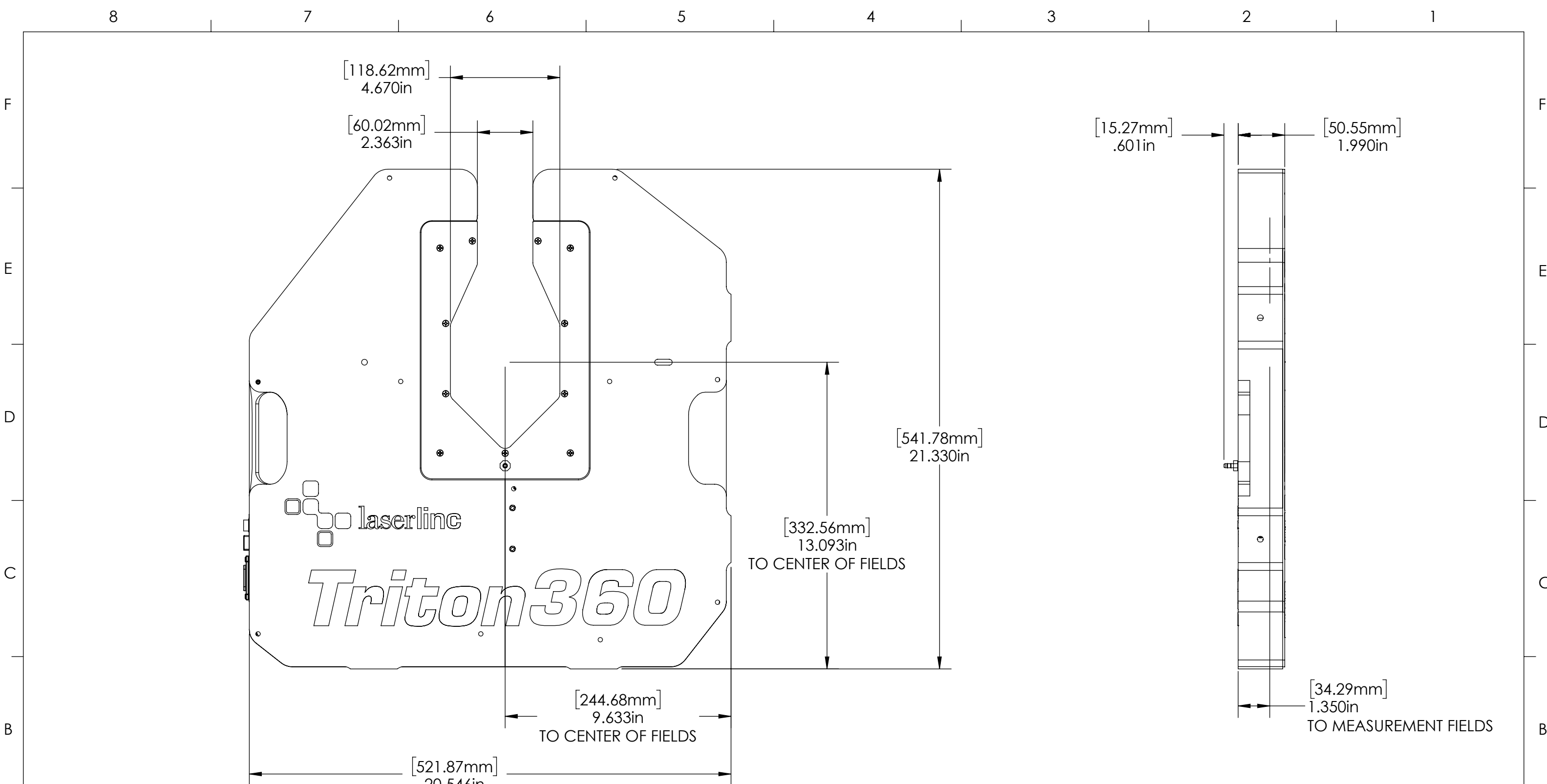

GENERAL FINISH NOTE DE-BURR AND BREAK ALL SHARP EDGES BEFORE FINISH AND/OR SHIPPING	UNLESS OTHERWISE SPECIFIED: DIMENSIONS ARE IN INCHES TOLERANCES: ANGLES ±.25° TWO PLACE DECIMAL ±0.010 THREE PLACE DECIMAL ±0.005 FOUR PLACE DECIMAL ±0.0005 UNMARKED FILLETS/CHAMFER .06 DE-BURR ALL PARTS	NAME EMM	DATE 11/20/2020	LaserLinc, Inc. Phone: 888-707-4892 Info@laserlinc.com www.laserlinc.com
	PROPRIETARY AND CONFIDENTIAL	INTERPRET GEOMETRIC TOLERANCING PER: ASME Y14.5	DRAWN BY:	
THE INFORMATION CONTAINED IN THIS DRAWING IS THE SOLE PROPERTY OF LASERLINC, INC. ANY REPRODUCTION IN PART OR AS A WHOLE WITHOUT THE WRITTEN PERMISSION OF LASERLINC, INC. IS PROHIBITED.	MATERIAL	63 RA SURFACE FINISH ALL FEATURES MUST MEET SPECIFICATION AFTER PLATING BEFORE POWDER-COAT IF PLATED OR POWDER-COATED SEE FINISH		SIZE B
DO NOT SCALE DRAWING	FINISH	DWG. NO. 0360-0000-30	REV B	SCALE: 1:4
		SHEET 3 OF 3		